

# ISL28213/14MSOPEVAL2Z Evaluation Board User's Guide

## Introduction

The ISL28213/14MSOPEVAL2Z evaluation board is a design platform containing all the circuitry needed to characterize critical performance parameters of the ISL28213 and ISL28214 operational amplifiers, using a variety of user defined test circuits.

The ISL28213 and ISL28214 CMOS operational amplifiers feature low power consumption, low input bias current, and rail-to-rail input and output drive capability. They are designed to operate with a single lithium cell or two Ni\_Cd batteries.

## Reference Documents

- ISL28213/14MSOPEVAL2Z Evaluation Board User's Guide
- ISL28213 Data Sheet, [FN6728](#)
- ISL28214 Data Sheet, [FN6800](#)

## Evaluation Board Key Features

The ISL28213/14MSOPEVAL2Z is designed to enable the IC to operate from a single supply, +2.4VDC to +5.5VDC or from split supplies, ±1.2VDC to ±2.75V. The board is configured for a dual op amp connected for differential input with a closed loop gain of 10. A single external reference voltage (VREF) pin and provisions for a user-selectable voltage divider - filter are included.

## Power Supplies (Figure 1)

External power connections are made through the +V, -V, VREF and Ground connections on the evaluation board. For single supply operation, the -V and Ground pins are tied together to the power supply negative terminal. For split supplies, +V and -V terminals connect to their

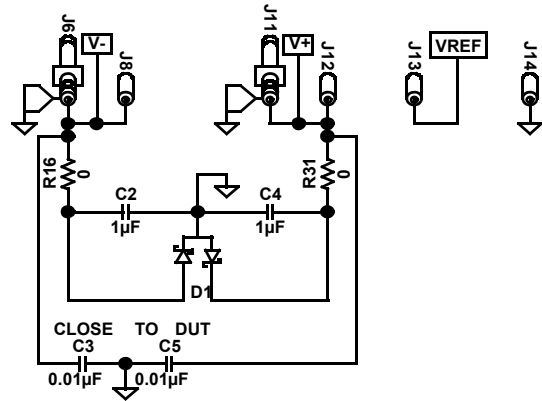
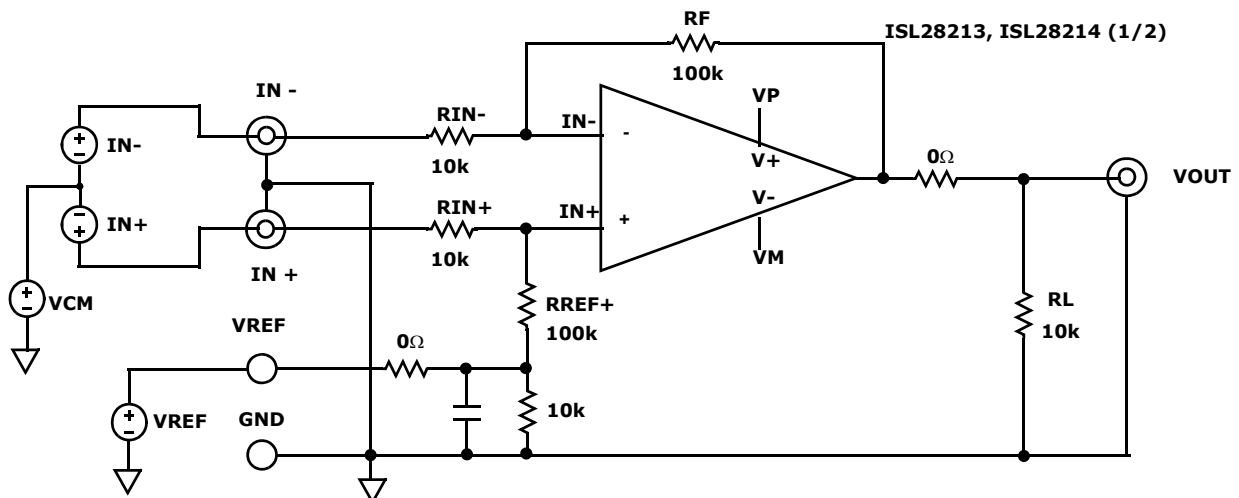

**FIGURE 1. POWER SUPPLY CIRCUIT**

respective power supply terminals. De-coupling capacitors C2 and C4 connect to their respective supplies through R<sub>16</sub> and R<sub>31</sub> 0Ω resistors. These resistors are 0Ω, but can be changed by the user to provide additional power supply filtering. Two additional capacitors, C3 and C5, are connected close to the DUT to filter out high frequency noise. Anti-reverse diode D1 protects the circuit in the case of accidental polarity reversal.

## Amplifier Configuration (Figure 2)

The schematic of 1/2 of the op-amp with the components supplied is shown in Figure 2. The circuit implements a differential input amp with a closed loop gain of 10. The circuit can operate from a single supply or from dual supplies. The VREF pin must be connected to ground to establish a ground referenced input for dual supply operation, or can be externally set to any reference level for single supply operation. VREF should not be left floating.



**FIGURE 2. BASIC AMPLIFIER CONFIGURATION**

## User-Selectable Options (Figures 3 and 4)

Component pads are included to enable a variety of user-selectable circuits to be added to the amplifier VREF, inputs, outputs, and the amplifier feedback loops. The inputs (see Figure 3) have additional resistor, capacitor, and jumper placements for loading and/or measurement of frequency sensitive parameters.

The outputs (see Figure 4) have a 10kΩ load resistor to ground and have additional resistor and capacitor placements for loading.

NOTE: Operational amplifiers are sensitive to output capacitance and may oscillate. In the event of oscillation, reduce output capacitance by using shorter cables, or add a resistor in series with the output.

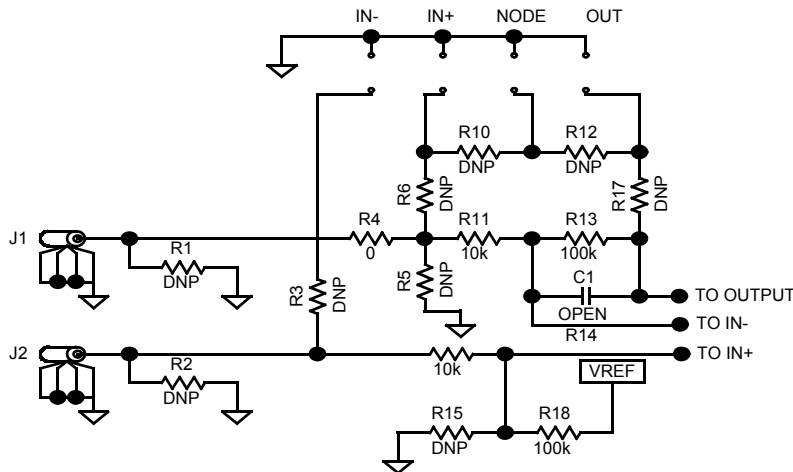

FIGURE 3. INPUT STAGE (1/2)

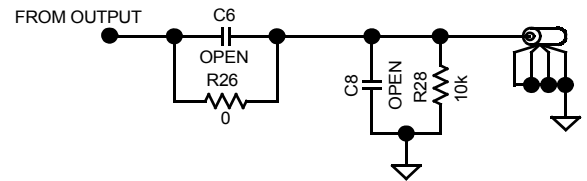

FIGURE 4. OUTPUT STAGE (1/2)

## ISL28213/14MSOPEVAL2Z Components Parts List

DEVICE #	DESCRIPTION	COMMENTS
C2, C4	CAP-TANTALUM, SMD, 1.0μF, 50V, 10%, LOW ESR, ROHS	Power Supply Decoupling
C3, C5	CAP, SMD, 0603, 0.1μF, 25V, 10%, X7R, ROHS	Power Supply Decoupling
C1, C6-C10	CAP, SMD, 0603, DNP-PLACE HOLDER, ROHS	User Selectable Capacitors - not populated
D1	DIODE-SCHOTTKY BARRIER, SMD, SOT-23, 3P, 40V, ROHS	Reverse Power Protection
U1 (ISL28213FUZ)	ISL28213FUZ-T7, IC-RAIL-TO-RAIL OP AMP, MSOP, ROHS	
U1 (ISL28214FUZ)	ISL28214FUZ-T7, IC-RAIL-TO-RAIL OP AMP, MSOP, ROHS	
R30, R32, R34-R36	RESISTOR, SMD, 0603, 0.1%, MF, DNP-PLACE HOLDER	User Selectable Resistors - not populated
R4, R16, R25-R27, R31	RES, SMD, 0603, 0Ω, 1/10W, TF, ROHS	0Ω User Selectable Resistors
R11, R14, R21, R24, R28, R29	RES, SMD, 0603, 10k, 1/10W, 1%, TF, ROHS	Gain and Other User Selectable Resistors
R13, R18, R19, R23	RES, SMD, 0603, 100k, 1/10W, 1%, TF, ROHS	Gain Resistors

ISL28213/14MSOPEVAL2Z

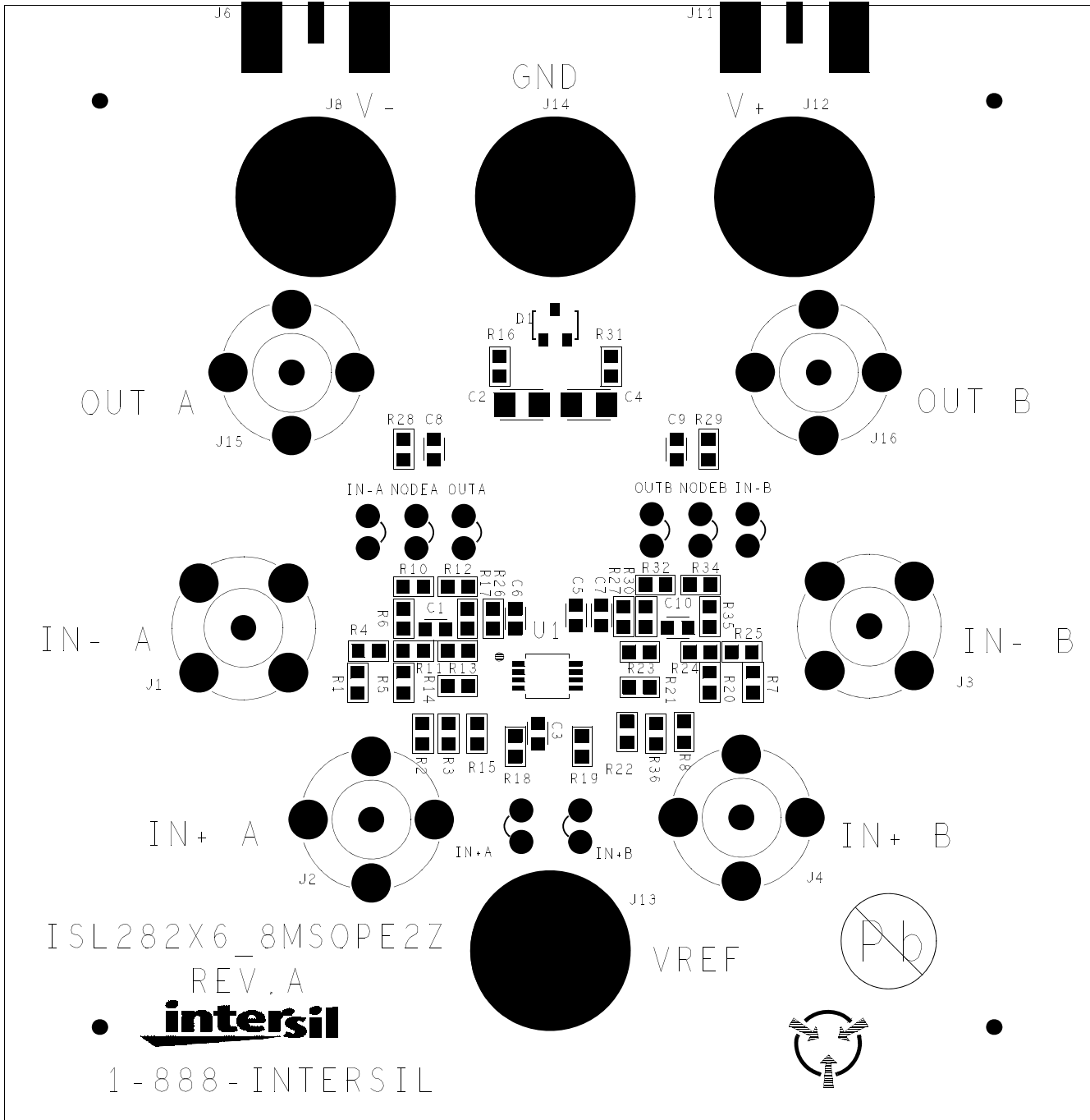

FIGURE 5. ISL28213/14MSOPEVAL2Z EVALUATION BOARD

Intersil Corporation reserves the right to make changes in circuit design, software and/or specifications at any time without notice. Accordingly, the reader is cautioned to verify that the Application Note or Technical Brief is current before proceeding.

For information regarding Intersil Corporation and its products, see [www.intersil.com](http://www.intersil.com)

### ISL28213/14MSOPEVAL2Z Schematic Diagram

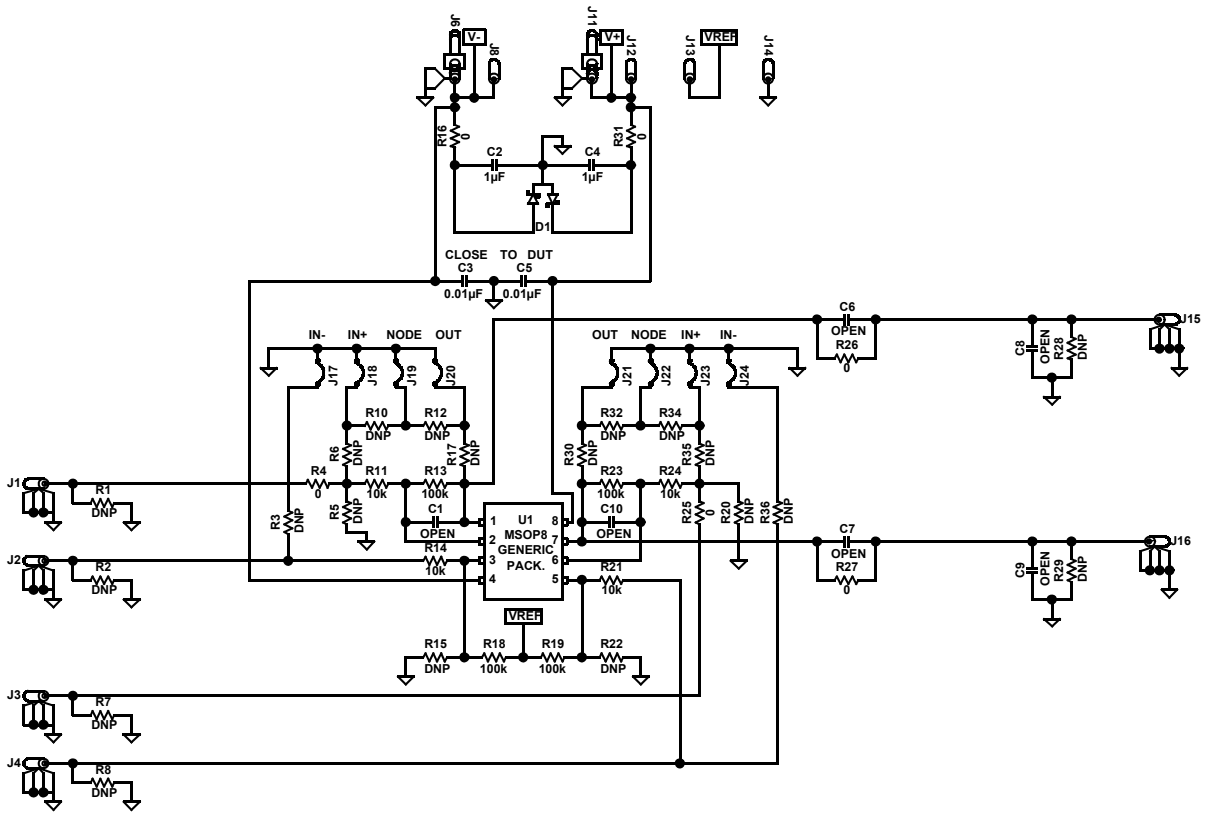

FIGURE 6.