

551012875, 551012922 Universal Op Amp Evaluation Boards (SOT-23 and SC-70)

Overview

The 551012875 and 551012922 Universal Evaluation Boards are designed to aid in the evaluation and testing of National Semiconductor's low voltage/ low power and some precision operational amplifiers. These boards will accommodate op amps that are assembled in a 6-Pin or 5-Pin SOT-23 and SC-70 package, regardless of the pin orientation.

This board is designed to use one or two amplifiers. Many different circuits can be made such as inverting, non-inverting, and differential-IN-differential-OUT amplifiers and low-pass, high-pass, band-pass, band-reject, or notch second-order filters. The amplifiers can be powered with single or dual supplies. These circuits can be configured without any modifications to the board; all that is necessary is to select the correct resistors and capacitors. The other optional components can be left open or shorted depending on the configuration desired.

These universal evaluation boards are designed as two-layer boards; the top side of each is designed for op amps with a pinout as shown in [Figure 1](#).

The bottom side of each board is designed for op amps with the pinout shown in [Figure 2](#). The board has been manufactured with vias connecting the equivalent pins of the top and bottom amplifiers. For example, Pin 1 of IC_{1A} is connected to Pin 3 of IC_{2A}. Similarly all other equivalent pins of the top and bottom amplifiers are connected. This allows for an efficient use of one board to test two amplifiers of different package types while keeping the same components on the board; just make sure that only one amplifier is soldered to the same pads.

Circuit performance of this evaluation board will be comparable to final production designs. Use this evaluation board as a guide for general layout and a tool to aid in device testing and characterization.

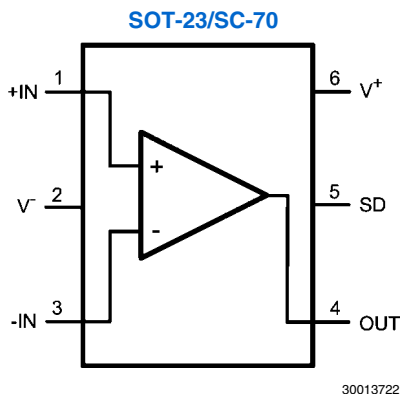

FIGURE 1. Connection Diagram for IC_{1A} and IC_{1B}

National Semiconductor
Application Note 1606
Mike Stout
September 8, 2009

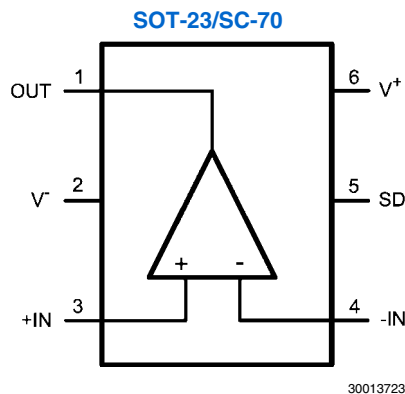

FIGURE 2. Connection Diagram for IC_{2A} and IC_{2B}

Hardware Setup

COMPONENT NOTATION

The pins of the footprint for IC_{1A} are connected to the equivalent pins for the footprint of IC_{2A} and the same is true for IC_{1B} and IC_{2B}. Therefore, this document will refer to the amplifier in IC_{1A} or IC_{2A} as Amp A and the amplifier in IC_{1B} or IC_{2B} as Amp B. The subscript of the PCB component refers to the specific amplifier; for example, R_{4A} is used for Amp A and R_{4B} for Amp B. In this document, components will be referred to, as an example, C₃. If using Amp A this refers to component C_{3A}, if using Amp B this refers to component C_{3B}.

In some circuits, a resistor will be installed where the PCB is labeled for a capacitor or a capacitor will be installed where a resistor is labeled. For example, C_{R6} indicates that a capacitor should be in the R₆ position. R_{C5} means that a resistor will be installed in the C₅ position.

POWER

Power is applied to the points labeled V⁻, GND, and V⁺. If a single supply is used, then V⁻ should be connected to GND. A virtual ground, halfway between the positive supply voltage and ground, is the reference point for the input and output voltages. The output voltage swings above and below this virtual ground. Single-supply operation requires the generation of this virtual ground, usually at a voltage equal to V⁺/2. The circuit in [Figure 3](#) can be used to generate V⁺/2; R₁ and R₂ should be of equal values. This junction along with capacitor C₁ will form a low-pass filter used to eliminate conducted noise or transients on the positive supply rail.

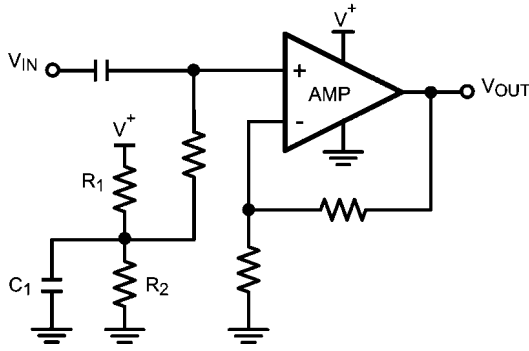

30013707

FIGURE 3. Single Supply Virtual Ground

OP AMP

Solder an op amp to either the IC_{1A} or IC_{2A} position. If building a circuit requiring two op amps, solder an additional op amp to either IC_{1B} or IC_{2B}. The corresponding pinout is shown on each side of the PCB.

BYPASSING

Install the following capacitors:

- C_{6A}, C_{9A}, C_{6B}, C_{9B}: 0.1 μF
- C_{7A}, C_{8A}, C_{7B}, C_{8B}: 1 μF

SHUTDOWN

To use the shutdown feature of the amplifier in either the SOT-23 or the SC-70 package, install a resistor at R₁₅ and an optional capacitor at C₁₁. The shutdown voltage is applied at S/D-A or S/D-B depending on the package of the amplifier being used.

INPUT AND OUTPUT

SMA connectors are used for the input and output of signals. They are located on the edges of the PCB.

Circuit Configurations

NON-INVERTING AMPLIFIER

- C₃ Short
- R₄ Short
- R₅ Short
- R₈ Input Termination
- R₇ Output series resistance (used for matching transmission lines or isolation)
- R₁₄ Gain Resistor
- R₁₂ Gain Resistor

Where

$$\frac{V_{OUT}}{V_{IN}} = 1 + \frac{R_{14}}{R_{12}}$$

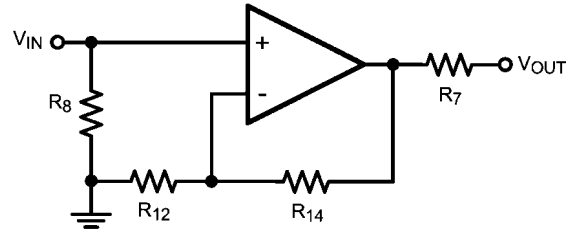

C₃, R₄, R₅ = 0 (SHORT)

30013709

FIGURE 4. Non-Inverting Amplifier

INVERTING AMPLIFIER

- C₃ Short
- R₉ Short
- R₁₃ Short
- R₈ Input Termination
- R₇ Output series resistance (used for matching transmission lines or isolation)
- R₁₄ Gain Resistor
- R₁₁ Gain Resistor

Where

$$\frac{V_{OUT}}{V_{IN}} = - \frac{R_{14}}{R_{11}}$$

Input Impedance: Set R_T to the desired input impedance. Calculate R₈ where

$$R_8 = \frac{R_{11} \times R_T}{R_{11} - R_T}$$

To cancel the input bias current set R₆ to the value calculated with the following formula:

$$R_6 = \frac{R_{11} \times R_{14}}{R_{11} - R_{14}}$$

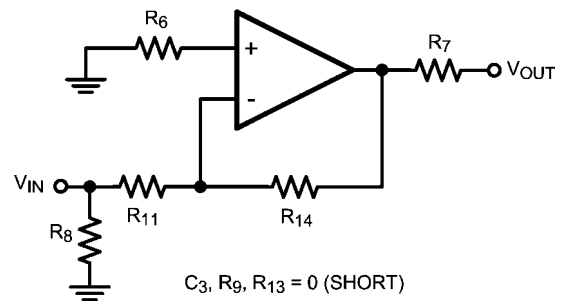

C₃, R₉, R₁₃ = 0 (SHORT)

30013713

FIGURE 5. Inverting Amplifier

ACTIVE FILTER APPLICATIONS

Both Sallen-Key and Multiple Feedback filters can be built on this PCB. To design a filter, use the WEBENCH® tool at www.national.com. Performance at high frequencies is limited to the gain bandwidth product of the amplifier, but within this frequency range, these active filters can achieve very good accuracy, if low-tolerance resistors and capacitor are used.

SALLEN-KEY LOW-PASS FILTER

- C_3 Short
- R_{13} Short
- R_7 Output series resistance (used for matching transmission lines or isolation)
- R_8 Input Termination

Set the following as determined using WEBENCH:

- $R_4, R_5, C_{R6}, R_{14}, R_{12}$

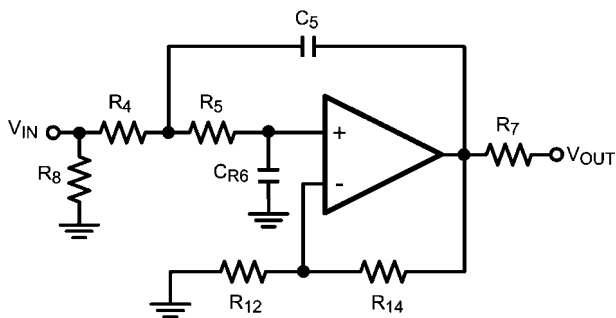

$C_3, R_{13} = 0$ (SHORT)

30013714

FIGURE 6. Sallen-Key Low-Pass Filter

MULTIPLE FEEDBACK LOW-PASS FILTER

- R_6 Short
- R_{13} Short
- R_9 Short
- C_5 Short
- R_7 Output series resistance (used for matching transmission lines or isolation)

Set the following as determined using WEBENCH:

- $R_{C3}, C_{R8}, R_4, R_{11}, C_{10}$

Note: If needed, an input termination resistor will need to be soldered on to the SMA connector between the signal pin and the ground pin.

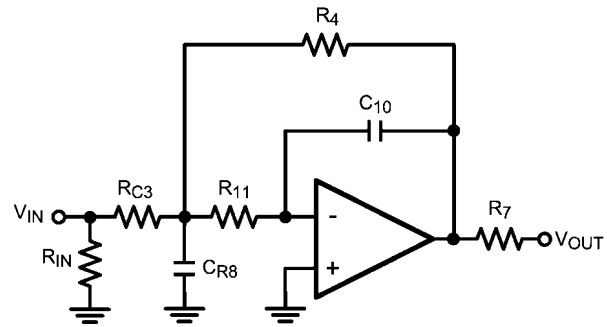

$R_6, R_{13}, R_9, C_5 = 0$ (SHORT)

30013715

FIGURE 7. Multiple Feedback Low-Pass Filter

SALLEN-KEY HIGH-PASS FILTER

- C_3 Short
- R_{13} Short
- R_{14} Short
- R_7 Output series resistance (used for matching transmission lines or isolation)
- R_8 Input Termination

Set as determined using WEBENCH:

- $C_{R4}, C_{R5}, R_{C5}, R_6$

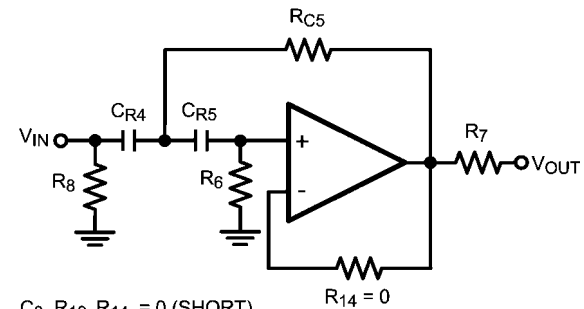

$C_3, R_{13}, R_{14} = 0$ (SHORT)

$R_{14} = 0$

30013716

FIGURE 8. Sallen-Key High-Pass Filter

MULTIPLE FEEDBACK HIGH-PASS FILTER

- R_9 Short
- R_4 Short
- R_7 Output series resistance (used for matching transmission lines or isolation)

Set the following as determined using WEBENCH:

- $C_3, R_8, C_5, C_{R11}, R_{14}$

Note: If needed, an input termination resistor will need to be soldered on to the SMA connector between the signal pin and the ground pin.

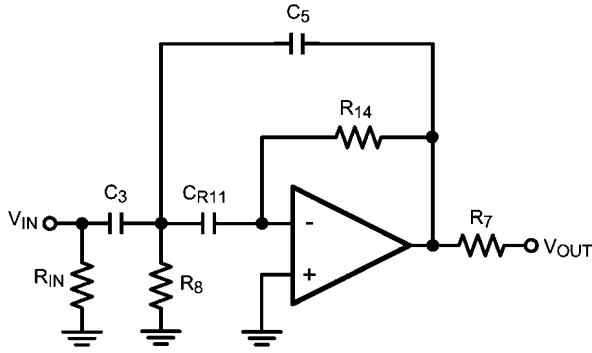

R₉, R₄ = 0 (SHORT)

30013717

FIGURE 9. Multiple Feedback High-Pass Filter

SALLEN-KEY BAND-PASS FILTER

- C₃ Short
- R₁₃ Short
- R₇ Output series resistance (used for matching transmission lines or isolation)
- R₈ Input Termination

Set as determined using WEBENCH:

R₄, C₄, C_{R5}, R₆, R_{C5}, R₁₄, R₁₂

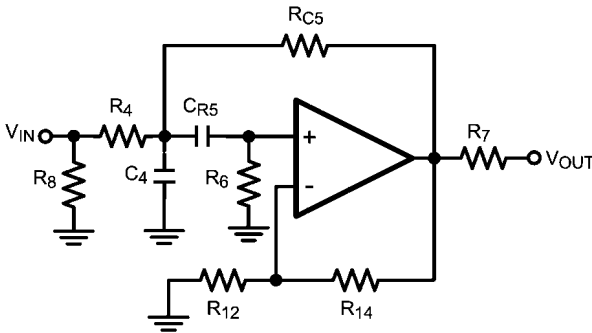

C₃, R₁₃ = 0 (SHORT)

30013718

FIGURE 10. Sallen-Key Band-Pass Filter

MULTIPLE FEEDBACK BAND-PASS FILTER

- R₆ Short
- R₁₃ Short
- R₉ Short
- R₄ Short
- R₇ Output series resistance (used for matching transmission lines or isolation)

Set the following as determined using WEBENCH:

R_{C3}, R₈, C₅, C_{R11}, R₁₄

Note: If needed, an input termination resistor will need to be soldered on to the SMA connector between the signal pin and the ground pin.

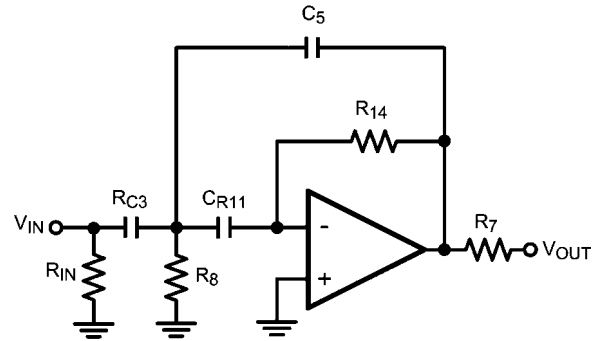

R₆, R₁₃, R₉, R₄ = 0 (SHORT)

30013719

FIGURE 11. Multiple Feedback Band-Pass Filter

Applications Using Two Amplifiers

TWO-AMPLIFIER FILTERS

Filters using two amplifiers can be built by connecting the output of Amp A to the input of Amp B.

SINGLE-ENDED TO DIFFERENTIAL CONVERSION

The circuit in *Figure 12* will convert a single-ended signal to a differential signal. This is done by using the combination of an inverting amplifier and a non-inverting amplifier. Each amplifier generates output signals of equal magnitude but of opposite polarity. This topology is useful in applications where the signal source is single-ended, but the ADC requires a differential input. The board will need to be modified by connecting Input A to Input B with a jumper wire.

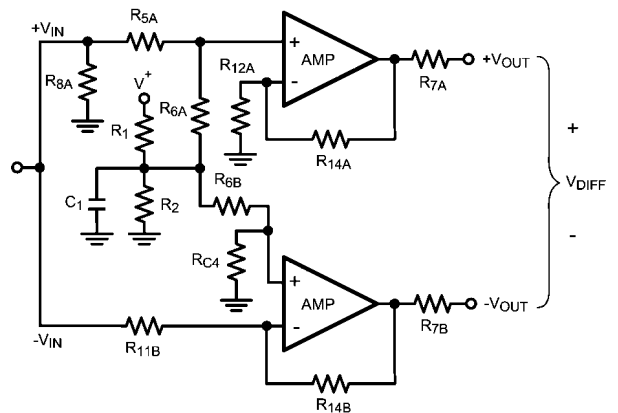

C_{3A}, R_{4A}, R_{5B}, R_{9B}, C_{3B} = 0 (SHORT)

30013720

FIGURE 12. Single-Ended to Differential Conversion

DIFFERENTIAL INPUT, DIFFERENTIAL OUTPUT, NON-INVERTING

Combining two non-inverting amplifiers with a common feedback network, as shown in [Figure 13](#), forms a non-inverting amplifier with a differential input and a differential output. Through the inherent cancellation of the two op amp common-mode error signals this configuration fully exploits the noise reduction benefits of CMRR. In addition the output voltage swing is doubled and depending on the op amp used, the bandwidth and slew rate may also be increased, while maintaining the original gain bandwidth specification.

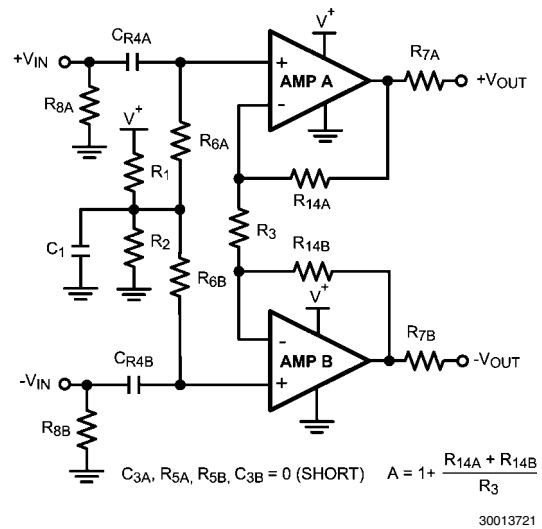
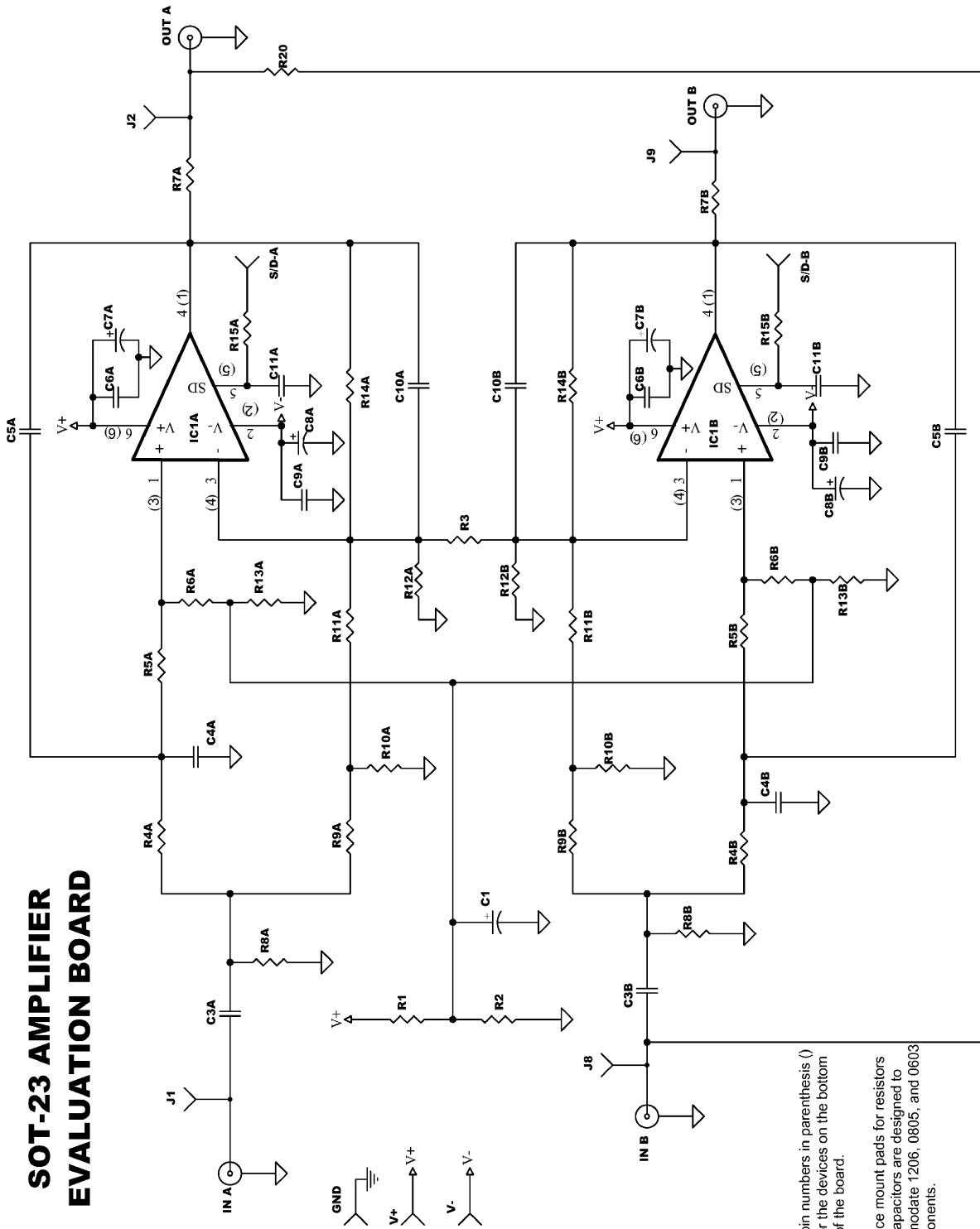

FIGURE 13. Differential Input, Differential Output, Non-Inverting

SOT-23 AMPLIFIER EVALUATION BOARD



Note: The pin numbers in parenthesis () are for the devices on the bottom side of the board.

Note: Surface mount pads for resistors and capacitors are designed to accommodate 1206, 0805, and 0603 components.

30013703

FIGURE 14. 551012875-001 Schematic

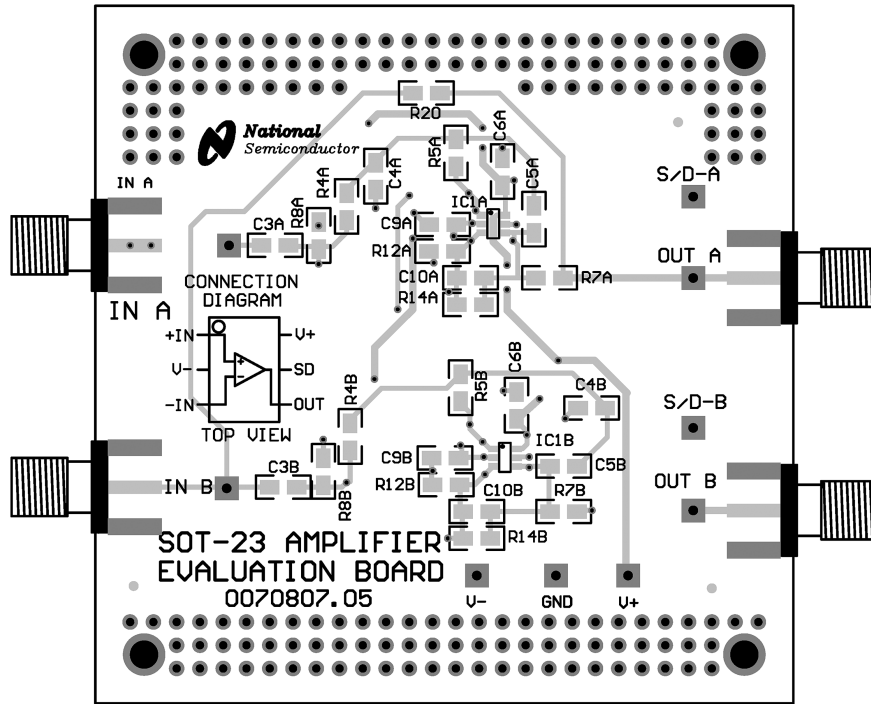

30013701

FIGURE 15. 551012875-001 Top Layout

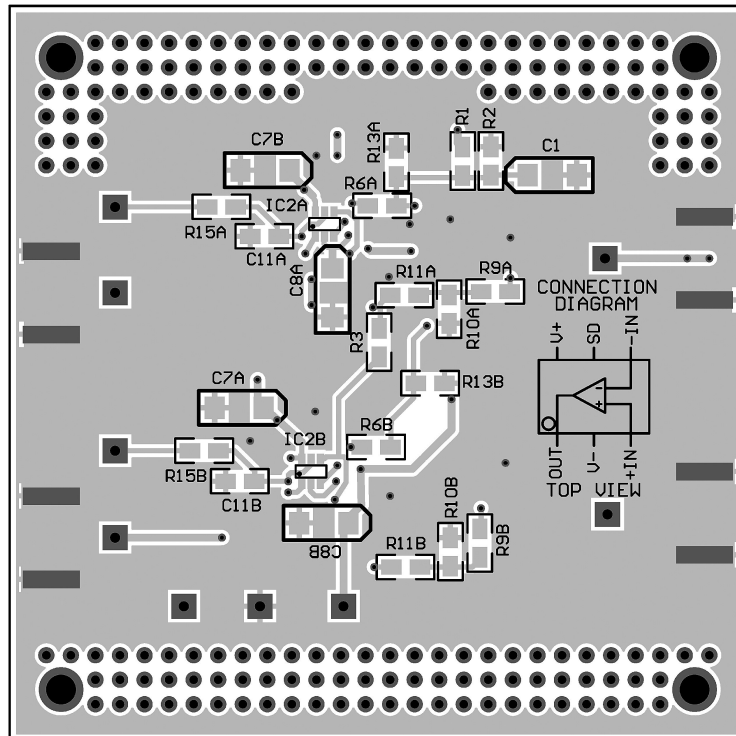

30013702

FIGURE 16. 551012875-001 Bottom Layout

**SC70-5 AMPLIFIER
EVALUATION BOARD
870012922-100 REV A**

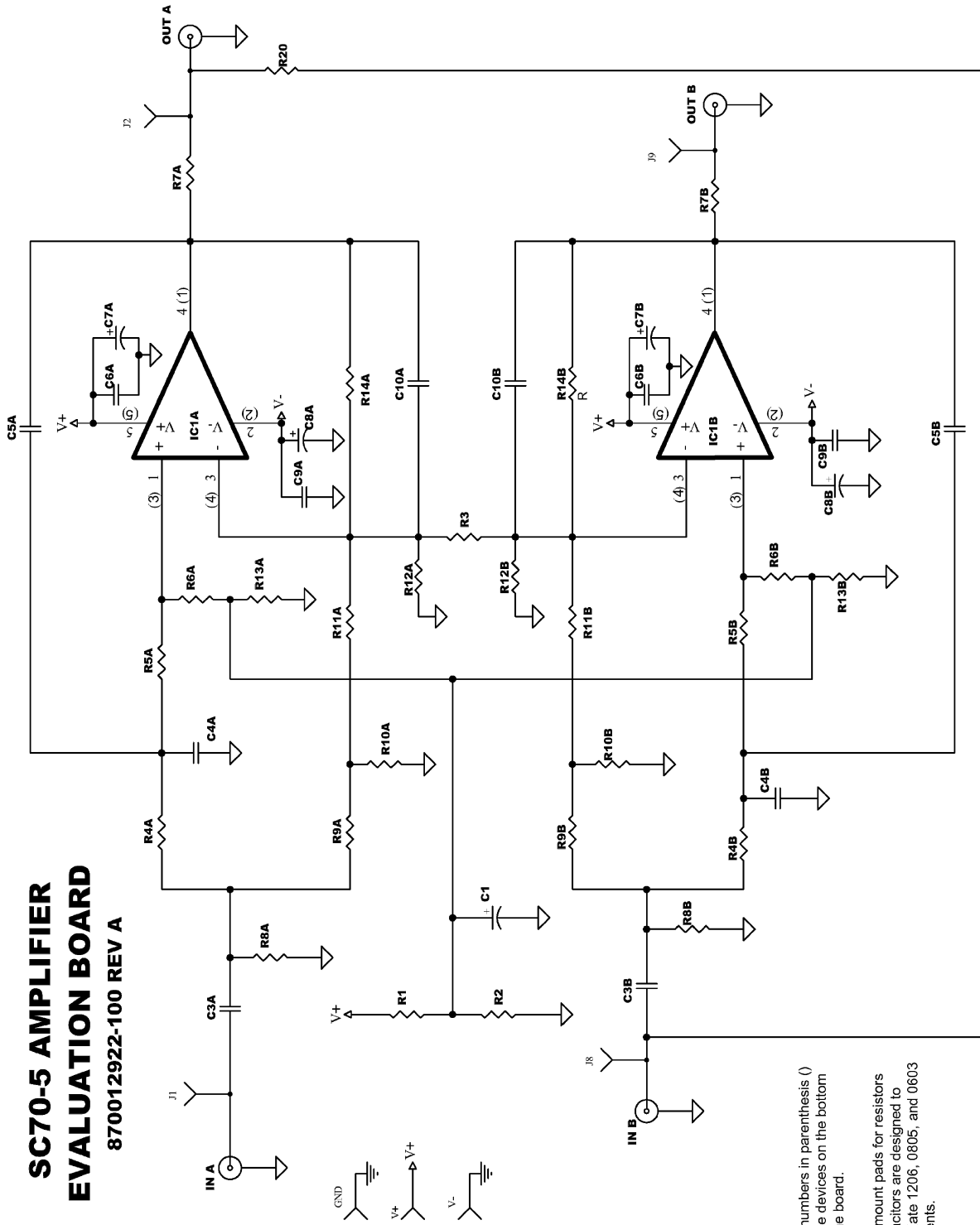

Note: The pin numbers in parenthesis () are for the devices on the bottom side of the board.

Note: Surface mount pads for resistors and capacitors are designed to accommodate 1206, 0805, and 0603 components.

FIGURE 17. 551012922-001 Schematic

30013706

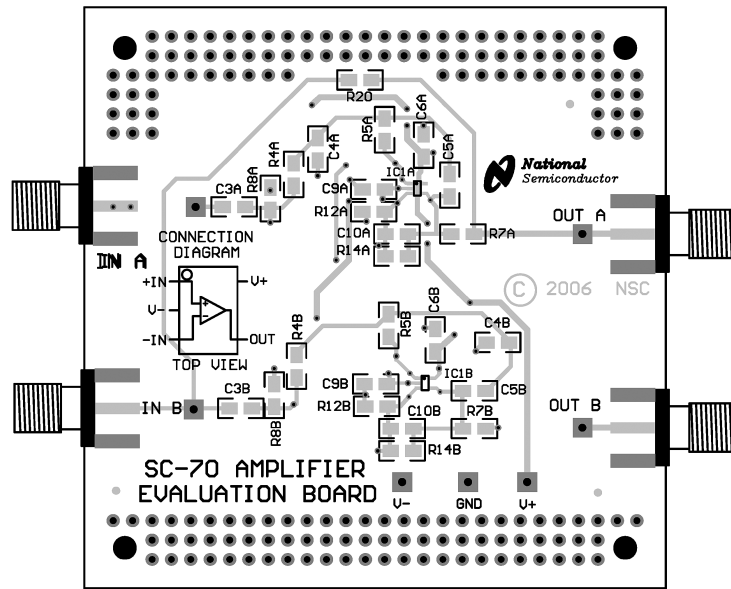

30013704

FIGURE 18. 551012922-001 Top Layout

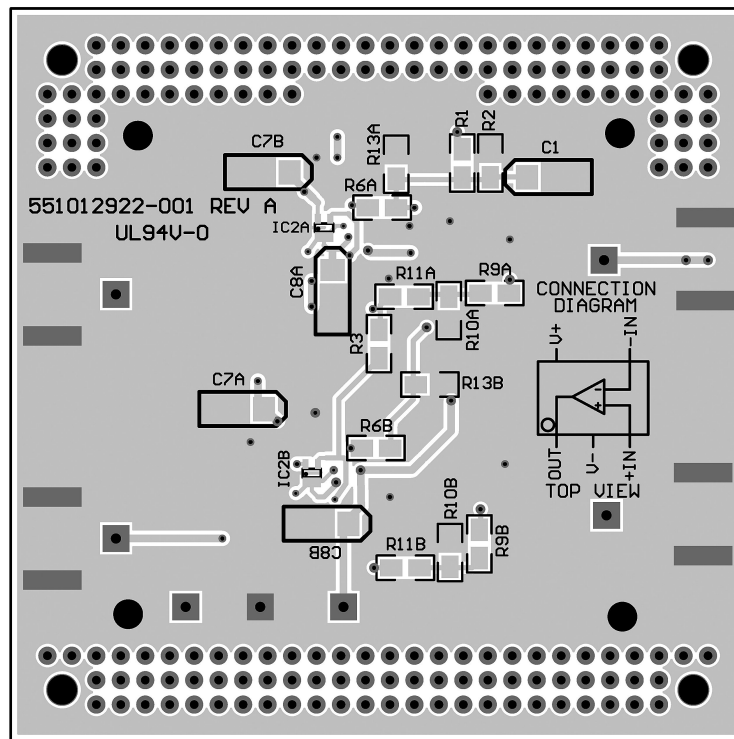

30013705

FIGURE 19. 551012922-001 Bottom Layout

Notes

For more National Semiconductor product information and proven design tools, visit the following Web sites at:

Products		Design Support	
Amplifiers	www.national.com/amplifiers	WEBENCH® Tools	www.national.com/webench
Audio	www.national.com/audio	App Notes	www.national.com/appnotes
Clock and Timing	www.national.com/timing	Reference Designs	www.national.com/refdesigns
Data Converters	www.national.com/adc	Samples	www.national.com/samples
Interface	www.national.com/interface	Eval Boards	www.national.com/evalboards
LVDS	www.national.com/lvds	Packaging	www.national.com/packaging
Power Management	www.national.com/power	Green Compliance	www.national.com/quality/green
Switching Regulators	www.national.com/switchers	Distributors	www.national.com/contacts
LDOs	www.national.com/ldo	Quality and Reliability	www.national.com/quality
LED Lighting	www.national.com/led	Feedback/Support	www.national.com/feedback
Voltage Reference	www.national.com/vref	Design Made Easy	www.national.com/easy
PowerWise® Solutions	www.national.com/powerwise	Solutions	www.national.com/solutions
Serial Digital Interface (SDI)	www.national.com/sdi	Mil/Aero	www.national.com/milaero
Temperature Sensors	www.national.com/tempensors	SolarMagic™	www.national.com/solarmagic
Wireless (PLL/VCO)	www.national.com/wireless	PowerWise® Design University	www.national.com/training

THE CONTENTS OF THIS DOCUMENT ARE PROVIDED IN CONNECTION WITH NATIONAL SEMICONDUCTOR CORPORATION ("NATIONAL") PRODUCTS. NATIONAL MAKES NO REPRESENTATIONS OR WARRANTIES WITH RESPECT TO THE ACCURACY OR COMPLETENESS OF THE CONTENTS OF THIS PUBLICATION AND RESERVES THE RIGHT TO MAKE CHANGES TO SPECIFICATIONS AND PRODUCT DESCRIPTIONS AT ANY TIME WITHOUT NOTICE. NO LICENSE, WHETHER EXPRESS, IMPLIED, ARISING BY ESTOPPEL OR OTHERWISE, TO ANY INTELLECTUAL PROPERTY RIGHTS IS GRANTED BY THIS DOCUMENT.

TESTING AND OTHER QUALITY CONTROLS ARE USED TO THE EXTENT NATIONAL DEEMS NECESSARY TO SUPPORT NATIONAL'S PRODUCT WARRANTY. EXCEPT WHERE MANDATED BY GOVERNMENT REQUIREMENTS, TESTING OF ALL PARAMETERS OF EACH PRODUCT IS NOT NECESSARILY PERFORMED. NATIONAL ASSUMES NO LIABILITY FOR APPLICATIONS ASSISTANCE OR BUYER PRODUCT DESIGN. BUYERS ARE RESPONSIBLE FOR THEIR PRODUCTS AND APPLICATIONS USING NATIONAL COMPONENTS. PRIOR TO USING OR DISTRIBUTING ANY PRODUCTS THAT INCLUDE NATIONAL COMPONENTS, BUYERS SHOULD PROVIDE ADEQUATE DESIGN, TESTING AND OPERATING SAFEGUARDS.

EXCEPT AS PROVIDED IN NATIONAL'S TERMS AND CONDITIONS OF SALE FOR SUCH PRODUCTS, NATIONAL ASSUMES NO LIABILITY WHATSOEVER, AND NATIONAL DISCLAIMS ANY EXPRESS OR IMPLIED WARRANTY RELATING TO THE SALE AND/OR USE OF NATIONAL PRODUCTS INCLUDING LIABILITY OR WARRANTIES RELATING TO FITNESS FOR A PARTICULAR PURPOSE, MERCHANTABILITY, OR INFRINGEMENT OF ANY PATENT, COPYRIGHT OR OTHER INTELLECTUAL PROPERTY RIGHT.

LIFE SUPPORT POLICY

NATIONAL'S PRODUCTS ARE NOT AUTHORIZED FOR USE AS CRITICAL COMPONENTS IN LIFE SUPPORT DEVICES OR SYSTEMS WITHOUT THE EXPRESS PRIOR WRITTEN APPROVAL OF THE CHIEF EXECUTIVE OFFICER AND GENERAL COUNSEL OF NATIONAL SEMICONDUCTOR CORPORATION. As used herein:

Life support devices or systems are devices which (a) are intended for surgical implant into the body, or (b) support or sustain life and whose failure to perform when properly used in accordance with instructions for use provided in the labeling can be reasonably expected to result in a significant injury to the user. A critical component is any component in a life support device or system whose failure to perform can be reasonably expected to cause the failure of the life support device or system or to affect its safety or effectiveness.

National Semiconductor and the National Semiconductor logo are registered trademarks of National Semiconductor Corporation. All other brand or product names may be trademarks or registered trademarks of their respective holders.

Copyright© 2009 National Semiconductor Corporation

For the most current product information visit us at www.national.com



National Semiconductor Americas Technical Support Center
 Email: support@nsc.com
 Tel: 1-800-272-9959

National Semiconductor Europe Technical Support Center
 Email: europe.support@nsc.com

National Semiconductor Asia Pacific Technical Support Center
 Email: ap.support@nsc.com

National Semiconductor Japan Technical Support Center
 Email: jpn.feedback@nsc.com