

FEATURES

- Two AD8224 circuits
 - Dual channel
 - Differential output
- Easy to connect screw terminals
- Decoupled supply lines
- Pads for RFI filtering

GENERAL DESCRIPTION

The AD8224-EVALZ has two AD8224 instrumentation amplifier circuits: one circuit is configured for dual-channel operation, and the other is configured for single-channel, differential output operation. The inputs, outputs, references, and supplies are routed to screw terminals for easy connectivity.

The PCB board has four layers. The top and bottom layers are used for routing, and the two internal layers are ground planes. The ground plane was removed underneath the R_G resistors. This is a precaution against any capacitance mismatch at the R_G pins that may affect ac CMRR.

AD8224 EVALUATION BOARD

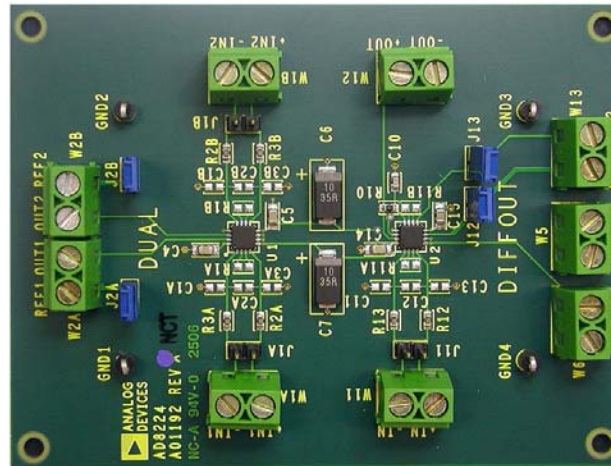

Figure 1.

Rev. 0

Evaluation boards are only intended for device evaluation and not for production purposes. Evaluation boards as supplied "as is" and without warranties of any kind, express, implied, or statutory including, but not limited to, any implied warranty of merchantability or fitness for a particular purpose. No license is granted by implication or otherwise under any patents or other intellectual property by application or use of evaluation boards. Information furnished by Analog Devices is believed to be accurate and reliable. However, no responsibility is assumed by Analog Devices for its use, nor for any infringements of patents or other rights of third parties that may result from its use. Analog Devices reserves the right to change devices or specifications at any time without notice. Trademarks and registered trademarks are the property of their respective owners. Evaluation boards are not authorized to be used in life support devices or systems.

One Technology Way, P.O. Box 9106, Norwood, MA 02062-9106, U.S.A.
Tel: 781.329.4700 www.analog.com
Fax: 781.461.3113 ©2007 Analog Devices, Inc. All rights reserved.

EVALUATION BOARD HARDWARE

JUMPER SETTINGS

Table 1.

Jumper	Purpose	Default
J1A, J1B, J11	Connect inputs together	Unconnected
J2A, J2B, J12, J13	Connect reference pins to ground	Connected

In the default factory setting, the reference pins of the AD8224 are connected to GND through J2A, J2B, J12, and J13. These jumpers also connect to W2A:REF1, W2B:REF2, W13:REF2, and W13:+IN2. Therefore, in the shipping configuration, W2A:REF1, W2B:REF2, W13:REF2, and W13:+IN2 are connected to GND. To disconnect the terminal from GND, remove the corresponding jumper.

QUICK START

The quick start feature assumes that the jumpers are in their default factory positions.

To begin:

1. Connect a ground lead to GND.
2. Connect a +15 V supply to +Vs.
3. Connect a -15 V supply to -Vs.
4. Ground -IN1.
5. Connect a 1 V p-p, 1 kHz source signal to +IN1. A replica of the signal should now appear at OUT1.

SETTING THE GAIN

The gain setting resistors are R1A and R1B for the dual-channel part and R11A for the differential output part. The pads are sized for 0603-sized resistors, although 0402 and 0805 sizes can also be used.

Table 2.

Channel	Component
Dual Channel A	R1A
Dual Channel B	R1B
Differential Output Channel	R11A

EMI FILTERING

The board comes with 0603 component pads for an EMI filter. These components are shown in Table 3.

Table 3.

Channel	Component
Dual Channel A	R3A, R2A, C1A, C2A, C3A
Dual Channel B	R3B, R2B, C1B, C2B, C3B
Differential Output Channel	R13, R12, C11, C12, C13

The board, as shipped, does not contain EMI filtering. The resistors pads are populated with 0 Ω resistors, and the capacitors are not populated.

See the [AD8224](#) data sheet for more information on EMI filtering.

EVALUATION BOARD SCHEMATICS

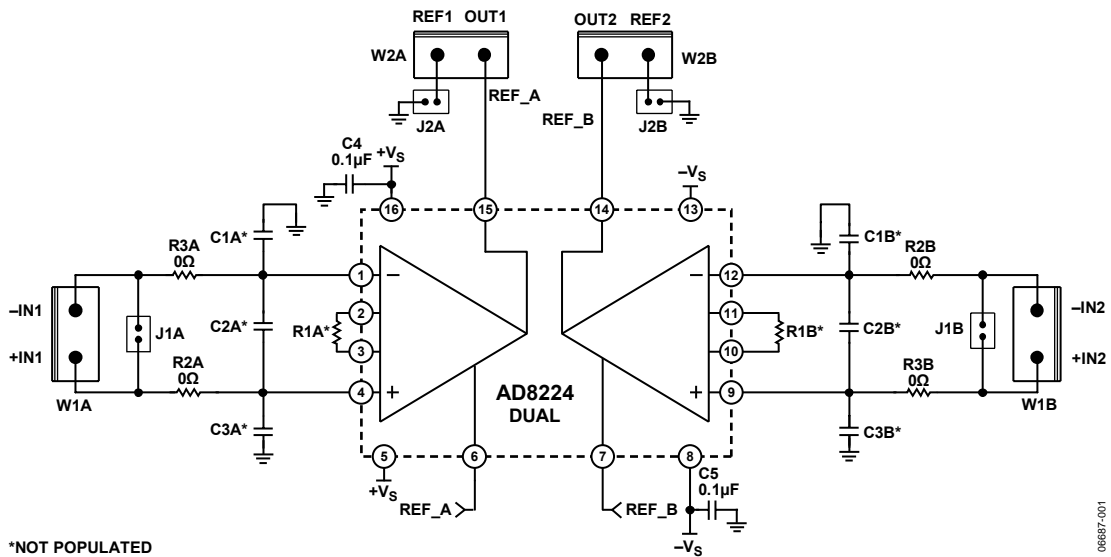

Figure 2. AD8224 Evaluation Board Schematic—AD8224 Dual Channel

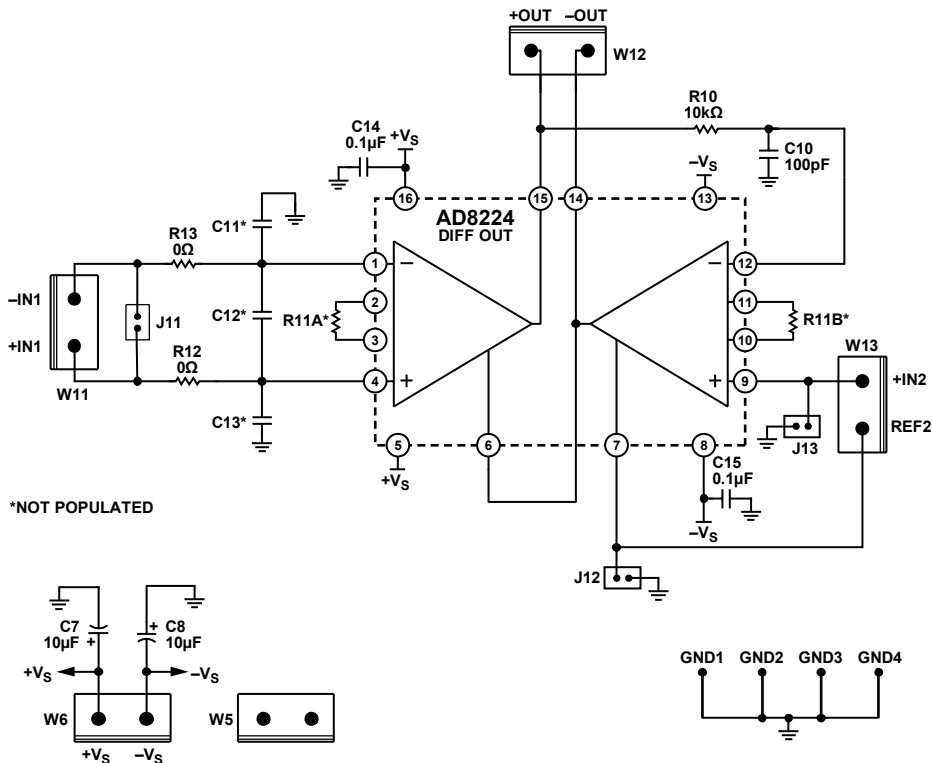

Figure 3. AD8224 Evaluation Board Schematic—AD8224 Differential Output

AD8224-EVALZ

ORDERING INFORMATION

ORDERING GUIDE

Model	Description
AD8224-EVALZ ¹	Evaluation Board

¹ Z = RoHS Compliant Part.

ESD CAUTION



ESD (electrostatic discharge) sensitive device. Charged devices and circuit boards can discharge without detection. Although this product features patented or proprietary protection circuitry, damage may occur on devices subjected to high energy ESD. Therefore, proper ESD precautions should be taken to avoid performance degradation or loss of functionality.