

# Evaluation Kit for PA97

## INTRODUCTION

This easy-to-use kit provides a platform for the evaluation of linear power amplifiers circuits using the PA97 pin-out. With ample breadboarding areas it is flexible enough to analyze a multitude of standard or proprietary circuit configurations. Critical connections for power supply bypassing are pre-wired. Components not usually readily available in engineering labs are provided. External connection to the evaluation kit can be made via the terminals at the edge of the circuit board. These terminal pads are suitable for standard banana jacks or direct soldering of wires. The schematic is shown in Figure 1.

## PARTS LIST

Part #	Description, Vendor	Quantity
EVAL23	PC Board, Apex Precision Power	1
P6KE440A	TransZorb, General Semiconductor (440V)	2
CDC01	Capacitor .01 $\mu$ F 1kV, Sprague 5GAS10	2

## ASSEMBLY

1. See Figure 1. Insert and solder the TransZorb diodes at D3 and D4 (440V).
2. Insert and solder the disc bypass capacitors at C1 and C2.
3. Jumper  $R_{LIM}$  and  $R_C$ . Note that heatsink HS28 is not used.
4. Add banana jacks as necessary to complete connections to external circuits and power supplies.
5. Insert the amplifier into the PCB mounting holes located in the space between the heatsink fins (not used) and solder pins.
6. Add other passive components as necessary to complete your circuit.
7. Most common configurations will ground the non-inverting pin of the amplifier. J1 is a convenient way to do this if necessary for your application circuit.
8. The four holes at the corners of the circuit board are for mounting #6 standoff spacers if desired.
9. R1-R5 are multiple feedback resistors in series. Commonly available resistors do not have a breakdown voltage sufficient to stand off the output voltage of the amplifier. Using multiple resistors will divide down the voltage that each resistor must withstand.

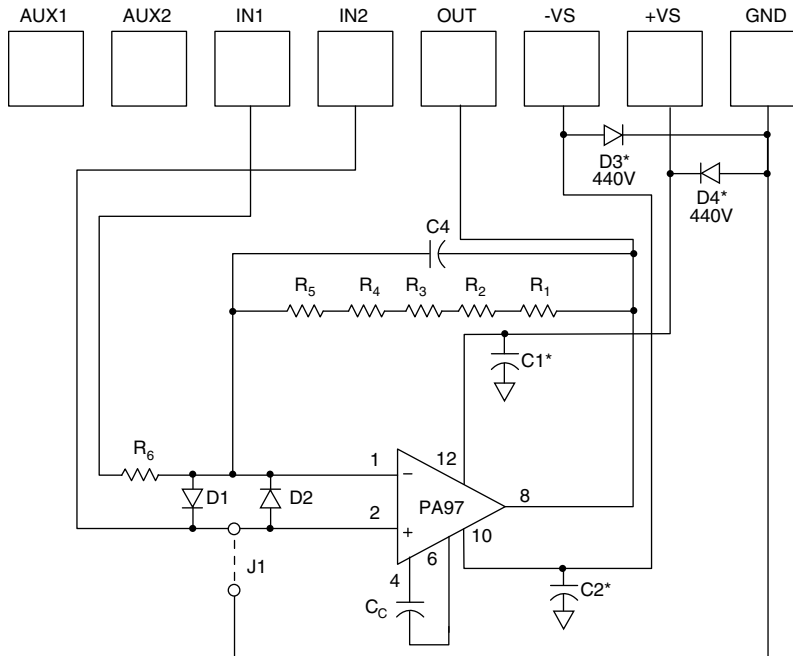
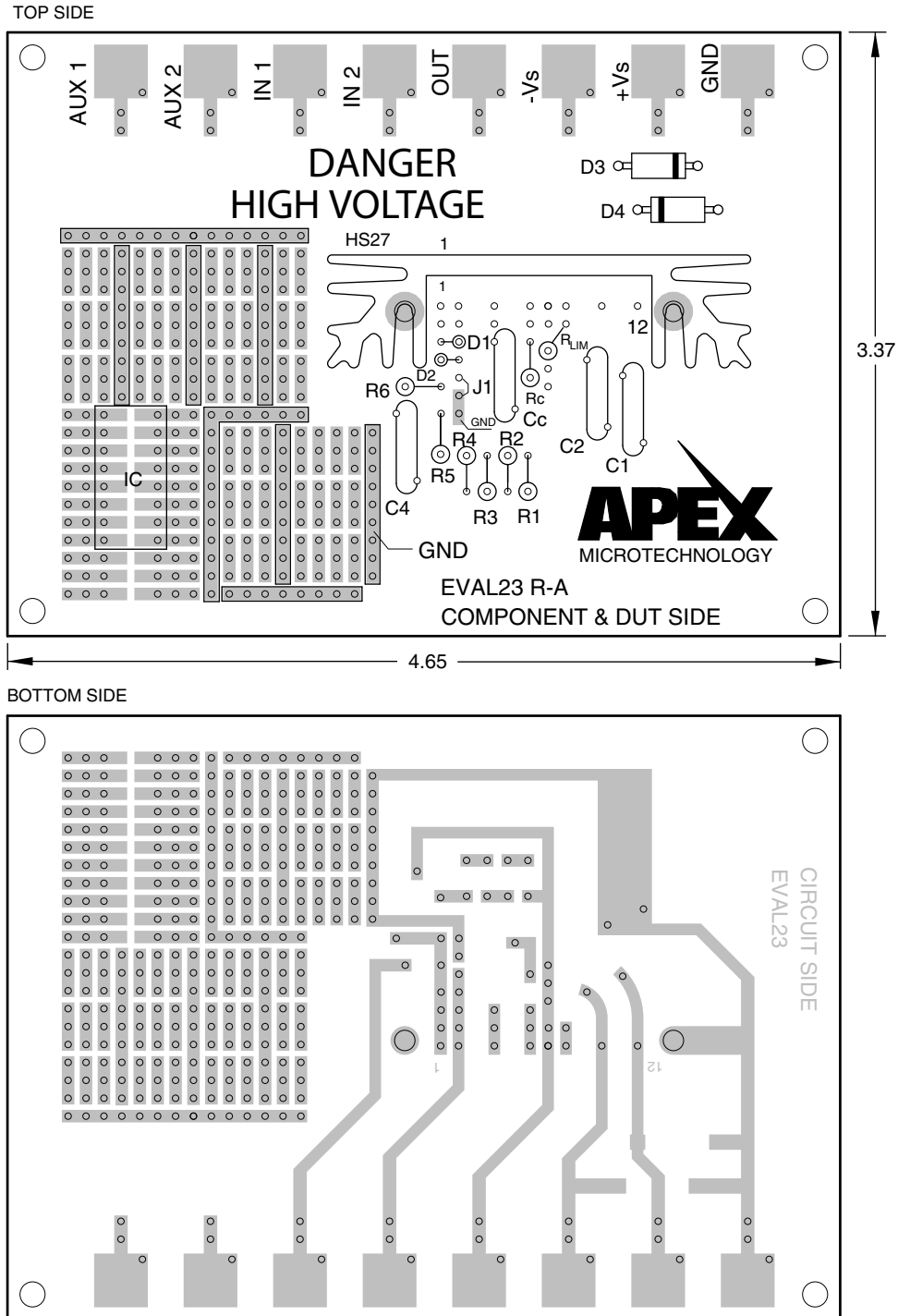

FIGURE 1.

Figure 1 shows the schematic of the evaluation kit's pre-wired connections. Components supplied with the kit are marked with an asterisk (\*). See the amplifier's data sheet for full application information.

FIGURE 2. PCB



---

## CONTACTING CIRRUS LOGIC SUPPORT

For all Apex Precision Power product questions and inquiries, call toll free 800-546-2739 in North America.

For inquiries via email, please contact [apex.support@cirrus.com](mailto:apex.support@cirrus.com).

International customers can also request support by contacting their local Cirrus Logic Sales Representative.

To find the one nearest to you, go to [www.cirrus.com](http://www.cirrus.com)

---

### IMPORTANT NOTICE

Cirrus Logic, Inc. and its subsidiaries ("Cirrus") believe that the information contained in this document is accurate and reliable. However, the information is subject to change without notice and is provided "AS IS" without warranty of any kind (express or implied). Customers are advised to obtain the latest version of relevant information to verify, before placing orders, that information being relied on is current and complete. All products are sold subject to the terms and conditions of sale supplied at the time of order acknowledgment, including those pertaining to warranty, indemnification, and limitation of liability. No responsibility is assumed by Cirrus for the use of this information, including use of this information as the basis for manufacture or sale of any items, or for infringement of patents or other rights of third parties. This document is the property of Cirrus and by furnishing this information, Cirrus grants no license, express or implied under any patents, mask work rights, copyrights, trademarks, trade secrets or other intellectual property rights. Cirrus owns the copyrights associated with the information contained herein and gives consent for copies to be made of the information only for use within your organization with respect to Cirrus integrated circuits or other products of Cirrus. This consent does not extend to other copying such as copying for general distribution, advertising or promotional purposes, or for creating any work for resale.

CERTAIN APPLICATIONS USING SEMICONDUCTOR PRODUCTS MAY INVOLVE POTENTIAL RISKS OF DEATH, PERSONAL INJURY, OR SEVERE PROPERTY OR ENVIRONMENTAL DAMAGE ("CRITICAL APPLICATIONS"). CIRRUS PRODUCTS ARE NOT DESIGNED, AUTHORIZED OR WARRANTED TO BE SUITABLE FOR USE IN PRODUCTS SURGICALLY IMPLANTED INTO THE BODY, AUTOMOTIVE SAFETY OR SECURITY DEVICES, LIFE SUPPORT PRODUCTS OR OTHER CRITICAL APPLICATIONS. INCLUSION OF CIRRUS PRODUCTS IN SUCH APPLICATIONS IS UNDERSTOOD TO BE FULLY AT THE CUSTOMER'S RISK AND CIRRUS DISCLAIMS AND MAKES NO WARRANTY, EXPRESS, STATUTORY OR IMPLIED, INCLUDING THE IMPLIED WARRANTIES OF MERCHANTABILITY AND FITNESS FOR PARTICULAR PURPOSE, WITH REGARD TO ANY CIRRUS PRODUCT THAT IS USED IN SUCH A MANNER. IF THE CUSTOMER OR CUSTOMER'S CUSTOMER USES OR PERMITS THE USE OF CIRRUS PRODUCTS IN CRITICAL APPLICATIONS, CUSTOMER AGREES, BY SUCH USE, TO FULLY INDEMNIFY CIRRUS, ITS OFFICERS, DIRECTORS, EMPLOYEES, DISTRIBUTORS AND OTHER AGENTS FROM ANY AND ALL LIABILITY, INCLUDING ATTORNEYS' FEES AND COSTS, THAT MAY RESULT FROM OR ARISE IN CONNECTION WITH THESE USES.

Cirrus Logic, Cirrus, and the Cirrus Logic logo designs, Apex Precision Power, Apex and the Apex Precision Power logo designs are trademarks of Cirrus Logic, Inc. All other brand and product names in this document may be trademarks or service marks of their respective owners.

---