

# LMP8601 Evaluation Board User's Manual

National Semiconductor  
Application Note 1940  
BeB Hennink  
February 6, 2009



## Introduction

The LMP8601 Current Sense evaluation Board is designed to evaluate the LMP8601, 60V Common Mode, Bidirectional Precision Current Sensing Amplifier. This board has a

LMP8601 part mounted on the PCB together with the required de-coupling capacitor, power supply connections, Input and Output connectors and a 3 pin header for connecting the off-set pin to either GND or  $V_S$ .

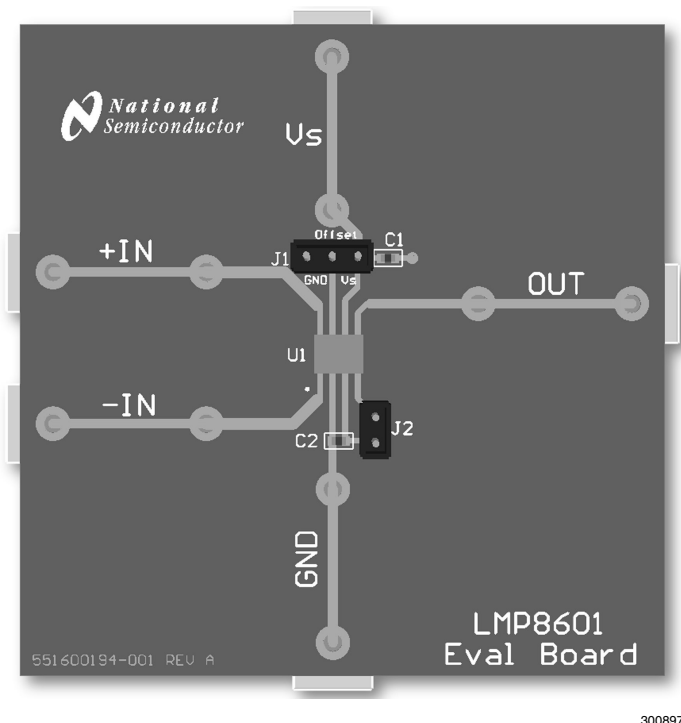

30089701

FIGURE 1. The LMP8601 Evaluation Board

## General Description

The LMP8601 and LMP8601Q are fixed 20x gain precision amplifiers. The part amplifies and filters small differential signals in the presence of high common mode voltages. The input common mode voltage range is  $-22V$  to  $+60V$  when operating from a single 5V supply. With 3.3V supply, the input common mode voltage range is from  $-4V$  to  $+27V$ . The LMP8601 and LMP8601Q are members of the Linear Monolithic Precision (LMP®) family and are ideal parts for unidirectional and bidirectional current sensing applications. All parameter values of the part that are shown in the tables of the LMP8601 data sheet are 100% tested and all bold values are also 100% tested over temperature.

The part has a precise gain of 20x which is adequate in most targeted applications to drive an ADC to its full scale value. The fixed gain is achieved in two separate stages, a preamplifier with a gain of 10x and an output stage buffer amplifier with a gain of 2x. The connection between the two stages of the signal path is brought out on two pins to enable the possibility to create an additional filter network around the output

buffer amplifier. These pins can also be used for alternative configurations with different gain as described in the applications section of the data sheet .

The mid-rail offset adjustment pin enables the user to use these devices for bidirectional single supply voltage current sensing. The output signal is bidirectional and mid-rail referenced when this pin is connected to the positive supply rail. With the offset pin connected to ground, the output signal is unidirectional and ground-referenced .

The LMP8601Q incorporates enhanced manufacturing and support processes for the automotive market, including defect detection methodologies. Reliability qualification is compliant with the requirements and temperature grades defined in the AEC Q100 standard

## LMP8601 Operating Conditions

- Temperature Range  $-40^{\circ}C$  to  $125^{\circ}C$
- Power Supply Voltage  $3.0V \leq V_S \leq 5.5V$
- CMVR at  $V_S = 3.3V$   $-4V$  to  $27V$
- CMVR at  $V_S = 5.0V$   $-22V$  to  $60V$

## Description of the LMP8601 Evaluation Board

The LMP8601 evaluation board requires a power supply with a voltage between 3.0V and 5.5V, the supply current will be <math><2\text{ mA}</math> in normal operation with high impedance load on the output of the part. The positive supply voltage is connected to  $V_S$  (P5). The negative supply voltage is connected to GND (P6).

The offset voltage on the output of the LMP8601 is determined by the voltage on the offset pin which is connected to pin2 of J1 and the offset voltage will be  $V_{\text{Offset}}/2$ . This pin is normally connected with a jumper to GND or  $V_S$ , but this pin can also be driven from a low impedance source ( $<10\ \Omega$ ).

With a jumper on J1 between 1–2 the offset pin is connected to  $V_S$  and the offset voltage is half the value of  $V_S$ . In this configuration the LMP8601 can be used for measuring bidirectional currents.

With a jumper on J1 between 2–3 the offset pin is connected to GND and the output voltage is ground referenced. In this configuration the LMP8601 is used for measuring unidirectional currents.

The input signal is connected between +IN (P1) and –IN (P2) and the output signal is available at OUT (P3).

On the board there is the possibility to place a capacitor C2 which creates a low pass filter between the first and second stage. This can be used to reduce the output noise and glitches that might appear from switching large common mode voltages with very fast transients at the input. (Please see the application section of the LMP8601 data sheet for more details about this filter).

the Header J2 is normally shorted with a jumper and connects the first stage to the second stage. The application section of the LMP8601 data sheet explains more about the alternative configurations that can be made after removing the jumper on J2.

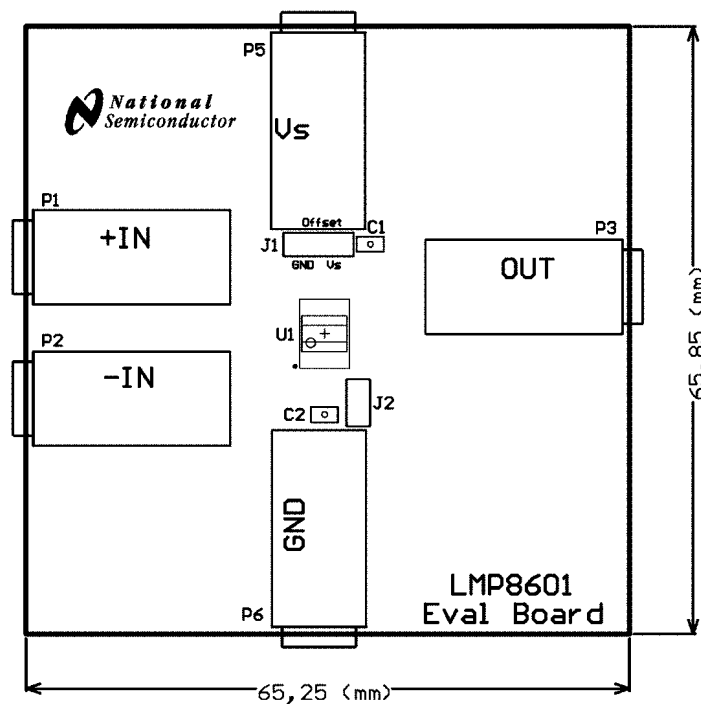

30089704

FIGURE 2. Power Supply Connectors and Headers

### PCB Layout Guidelines

This section provides general practical guidelines for PCB layouts that use various power and ground traces. Designers should note that these are only "rule-of-thumb" recommendations and the actual results are predicated on the final layout.

#### DIFFERENTIAL SIGNALS

The two input pins of the LMP8601 form a differential pair that must be handled following the rules given below.

- Keep both signals coupled by routing them closely together and keeping them of equal length.

- Do not allow any other signal in between these two signals of the differential pair.
- Keep all impedances in both traces of the signal equal.

#### POWER, GROUND AND DE-COUPLING

Keep the power supply de-coupling capacitor close to the power supply pin ( $V_S$  of the part.)

Make sure all return currents of the signals can flow next to the originating signals

## Description of Headers and Connectors of the LMP8601 Evaluation Board

The LMP8601 Evaluation Board provides the following headers and connectors for connecting test equipment and supplying the LMP8601 part.

### Connector and Header Functions

Designator	Function or Use	Comment
J1	Offset selection	1–2 Mid rail offset (Bi-directional) 2–3 Ground Referenced (unidirectional)
J2 the second stage	Short to connect first stager output to output amplifier input	Normally shorted
P1	Positive Input	
P2	Negative Input	
P3	Output	
P5	supply $V_S$	
P6	ground connection (GND)	

### Schematic

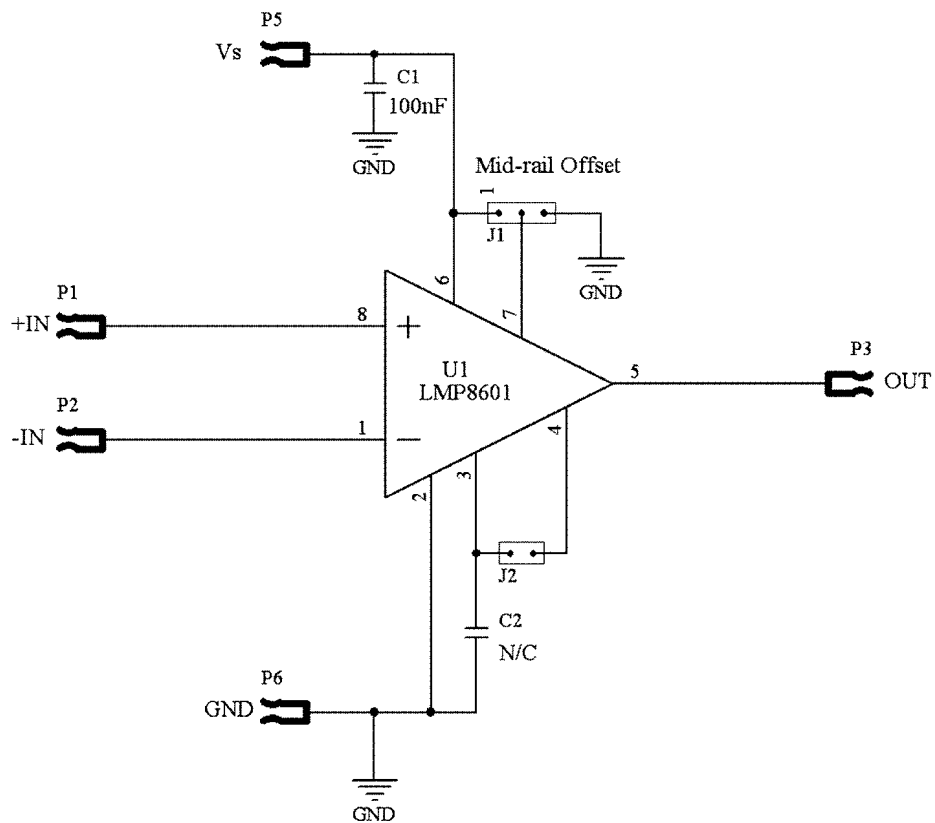

Layout

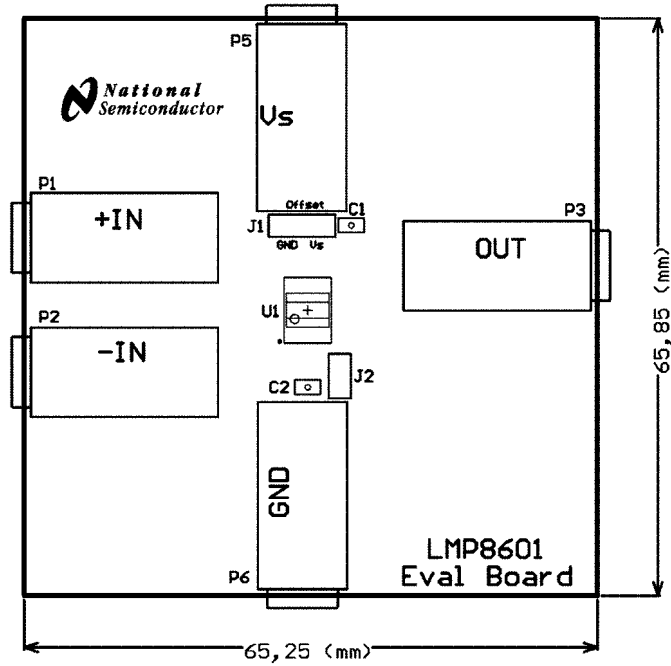

30089707

FIGURE 3. Layout, Silk Screen

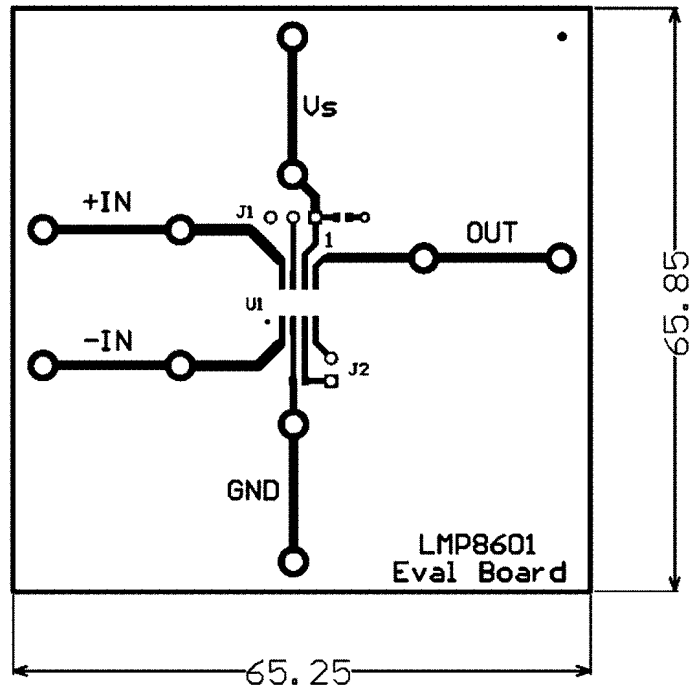

30089706

FIGURE 4. Layout, Top Layer

## Bill of Materials

Designator	Component	Value	Tolerance	Comment	Package Type
C1	Capacitor	100 nF			0603
C2	Capacitor	N/A			0603
J1	Header 2 pin			Mid-rail Offset	
J2	Header 2 pin				
P1	Banana plug	YELLOW		+IN	Banana_COLOR
P2	Banana plug	WHITE		-IN	Banana_COLOR
P3	Banana plug	BLUE		OUT	Banana_COLOR
P5	Banana plug	RED		V <sub>S</sub>	Banana_COLOR
P7	Banana plug	BLACK		GND	Banana_COLOR
U1	LMP8601	LMP8601QMA			M08A_N

## Notes

For more National Semiconductor product information and proven design tools, visit the following Web sites at:

Products		Design Support	
Amplifiers	<a href="http://www.national.com/amplifiers">www.national.com/amplifiers</a>	WEBENCH® Tools	<a href="http://www.national.com/webench">www.national.com/webench</a>
Audio	<a href="http://www.national.com/audio">www.national.com/audio</a>	App Notes	<a href="http://www.national.com/appnotes">www.national.com/appnotes</a>
Clock and Timing	<a href="http://www.national.com/timing">www.national.com/timing</a>	Reference Designs	<a href="http://www.national.com/refdesigns">www.national.com/refdesigns</a>
Data Converters	<a href="http://www.national.com/adc">www.national.com/adc</a>	Samples	<a href="http://www.national.com/samples">www.national.com/samples</a>
Interface	<a href="http://www.national.com/interface">www.national.com/interface</a>	Eval Boards	<a href="http://www.national.com/evalboards">www.national.com/evalboards</a>
LVDS	<a href="http://www.national.com/lvds">www.national.com/lvds</a>	Packaging	<a href="http://www.national.com/packaging">www.national.com/packaging</a>
Power Management	<a href="http://www.national.com/power">www.national.com/power</a>	Green Compliance	<a href="http://www.national.com/quality/green">www.national.com/quality/green</a>
Switching Regulators	<a href="http://www.national.com/switchers">www.national.com/switchers</a>	Distributors	<a href="http://www.national.com/contacts">www.national.com/contacts</a>
LDOs	<a href="http://www.national.com/ldo">www.national.com/ldo</a>	Quality and Reliability	<a href="http://www.national.com/quality">www.national.com/quality</a>
LED Lighting	<a href="http://www.national.com/led">www.national.com/led</a>	Feedback/Support	<a href="http://www.national.com/feedback">www.national.com/feedback</a>
Voltage Reference	<a href="http://www.national.com/vref">www.national.com/vref</a>	Design Made Easy	<a href="http://www.national.com/easy">www.national.com/easy</a>
PowerWise® Solutions	<a href="http://www.national.com/powerwise">www.national.com/powerwise</a>	Solutions	<a href="http://www.national.com/solutions">www.national.com/solutions</a>
Serial Digital Interface (SDI)	<a href="http://www.national.com/sdi">www.national.com/sdi</a>	Mil/Aero	<a href="http://www.national.com/milaero">www.national.com/milaero</a>
Temperature Sensors	<a href="http://www.national.com/tempsensors">www.national.com/tempsensors</a>	SolarMagic™	<a href="http://www.national.com/solarmagic">www.national.com/solarmagic</a>
Wireless (PLL/VCO)	<a href="http://www.national.com/wireless">www.national.com/wireless</a>	Analog University®	<a href="http://www.national.com/AU">www.national.com/AU</a>

THE CONTENTS OF THIS DOCUMENT ARE PROVIDED IN CONNECTION WITH NATIONAL SEMICONDUCTOR CORPORATION ("NATIONAL") PRODUCTS. NATIONAL MAKES NO REPRESENTATIONS OR WARRANTIES WITH RESPECT TO THE ACCURACY OR COMPLETENESS OF THE CONTENTS OF THIS PUBLICATION AND RESERVES THE RIGHT TO MAKE CHANGES TO SPECIFICATIONS AND PRODUCT DESCRIPTIONS AT ANY TIME WITHOUT NOTICE. NO LICENSE, WHETHER EXPRESS, IMPLIED, ARISING BY ESTOPPEL OR OTHERWISE, TO ANY INTELLECTUAL PROPERTY RIGHTS IS GRANTED BY THIS DOCUMENT.

TESTING AND OTHER QUALITY CONTROLS ARE USED TO THE EXTENT NATIONAL DEEMS NECESSARY TO SUPPORT NATIONAL'S PRODUCT WARRANTY. EXCEPT WHERE MANDATED BY GOVERNMENT REQUIREMENTS, TESTING OF ALL PARAMETERS OF EACH PRODUCT IS NOT NECESSARILY PERFORMED. NATIONAL ASSUMES NO LIABILITY FOR APPLICATIONS ASSISTANCE OR BUYER PRODUCT DESIGN. BUYERS ARE RESPONSIBLE FOR THEIR PRODUCTS AND APPLICATIONS USING NATIONAL COMPONENTS. PRIOR TO USING OR DISTRIBUTING ANY PRODUCTS THAT INCLUDE NATIONAL COMPONENTS, BUYERS SHOULD PROVIDE ADEQUATE DESIGN, TESTING AND OPERATING SAFEGUARDS.

EXCEPT AS PROVIDED IN NATIONAL'S TERMS AND CONDITIONS OF SALE FOR SUCH PRODUCTS, NATIONAL ASSUMES NO LIABILITY WHATSOEVER, AND NATIONAL DISCLAIMS ANY EXPRESS OR IMPLIED WARRANTY RELATING TO THE SALE AND/OR USE OF NATIONAL PRODUCTS INCLUDING LIABILITY OR WARRANTIES RELATING TO FITNESS FOR A PARTICULAR PURPOSE, MERCHANTABILITY, OR INFRINGEMENT OF ANY PATENT, COPYRIGHT OR OTHER INTELLECTUAL PROPERTY RIGHT.

#### LIFE SUPPORT POLICY

**NATIONAL'S PRODUCTS ARE NOT AUTHORIZED FOR USE AS CRITICAL COMPONENTS IN LIFE SUPPORT DEVICES OR SYSTEMS WITHOUT THE EXPRESS PRIOR WRITTEN APPROVAL OF THE CHIEF EXECUTIVE OFFICER AND GENERAL COUNSEL OF NATIONAL SEMICONDUCTOR CORPORATION.** As used herein:

Life support devices or systems are devices which (a) are intended for surgical implant into the body, or (b) support or sustain life and whose failure to perform when properly used in accordance with instructions for use provided in the labeling can be reasonably expected to result in a significant injury to the user. A critical component is any component in a life support device or system whose failure to perform can be reasonably expected to cause the failure of the life support device or system or to affect its safety or effectiveness.

National Semiconductor and the National Semiconductor logo are registered trademarks of National Semiconductor Corporation. All other brand or product names may be trademarks or registered trademarks of their respective holders.

Copyright© 2009 National Semiconductor Corporation

For the most current product information visit us at [www.national.com](http://www.national.com)



**National Semiconductor Americas Technical Support Center**  
Email: [support@nsc.com](mailto:support@nsc.com)  
Tel: 1-800-272-9959

**National Semiconductor Europe Technical Support Center**  
Email: [europe.support@nsc.com](mailto:europe.support@nsc.com)  
German Tel: +49 (0) 180 5010 771  
English Tel: +44 (0) 870 850 4288

**National Semiconductor Asia Pacific Technical Support Center**  
Email: [ap.support@nsc.com](mailto:ap.support@nsc.com)

**National Semiconductor Japan Technical Support Center**  
Email: [jpn.feedback@nsc.com](mailto:jpn.feedback@nsc.com)