

# LP38859S-1.2 Evaluation Board

National Semiconductor  
Application Note 1480  
Don Jones  
November 2006



## Introduction

This board is designed to enable the evaluation of the LP38859 Voltage Regulator. Each board is assembled and tested in the factory. This evaluation board has the TO-263 5-lead package mounted.

## General Description

The LP38859 is a dual-rail LDO linear regulator capable of supplying up to 3A of output current, and incorporates a Soft-Start feature.

The device has been designed to work with 10  $\mu\text{F}$  input and output ceramic capacitors, and 1 $\mu\text{F}$  bias capacitors. Footprints areas for  $C_{\text{IN}}$  and  $C_{\text{OUT}}$  will allow for a variety of sizes.

## Operation

The input voltage, applied between  $V_{\text{IN}}$  and GND, should be at least 1.0V greater than  $V_{\text{OUT}}$ , and no higher than the applied  $V_{\text{BIAS}}$  voltage.

The bias voltage, applied between  $V_{\text{BIAS}}$  and GND should be above the minimum bias voltage of 3.0V, and no higher than the maximum of 5.5V.

Loads can be connected to  $V_{\text{OUT}}$  with reference to GND.

$V_{\text{OUT}}$  and  $V_{\text{IN}}$  test points are provided on the board to allow accurate measurements directly on the evaluation board, eliminating any voltage drop on the PCB traces or connecting wires to the load.

The Soft-Start time for  $V_{\text{OUT}}$  is an exponential function, and is adjusted by changing the Soft-Start capacitor ( $C_{\text{SS}}$ ) on device pin one. An internal resistor ( $r_{\text{SS}}$ ) and the external capacitor ( $C_{\text{SS}}$ ) form an RC circuit. Five RC time constants is considered to be the Soft-Start time.

## Schematic Diagram

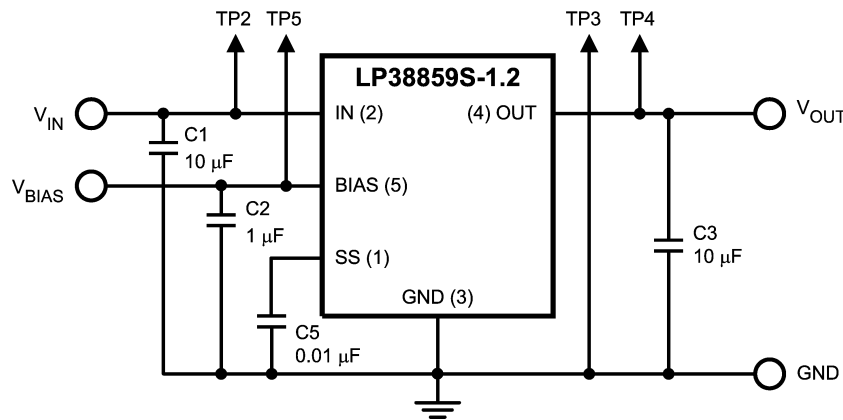

Evaluation Board Schematic

20193601

$$\text{Soft-Start Time} = 5 \times r_{\text{SS}} \times C_{\text{SS}}$$

The installed soft-start capacitor ( $C_{\text{SS}}$ ) is 10 nF (0.01  $\mu\text{F}$ ), and the internal  $r_{\text{SS}}$  is typically 16 k $\Omega$ .

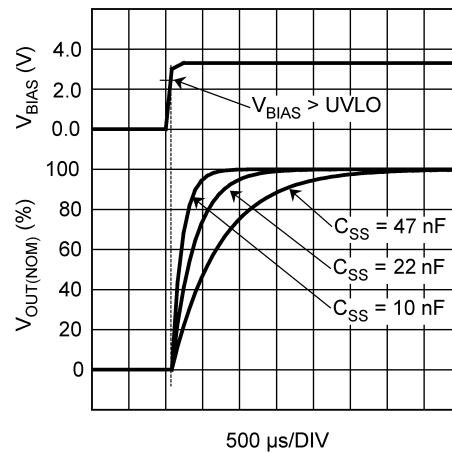

20193605

FIGURE 1.  $V_{\text{OUT}}$  vs  $C_{\text{SS}}$

## Hardware

The schematic and layout of the evaluation board are given below:

## PCB Layout

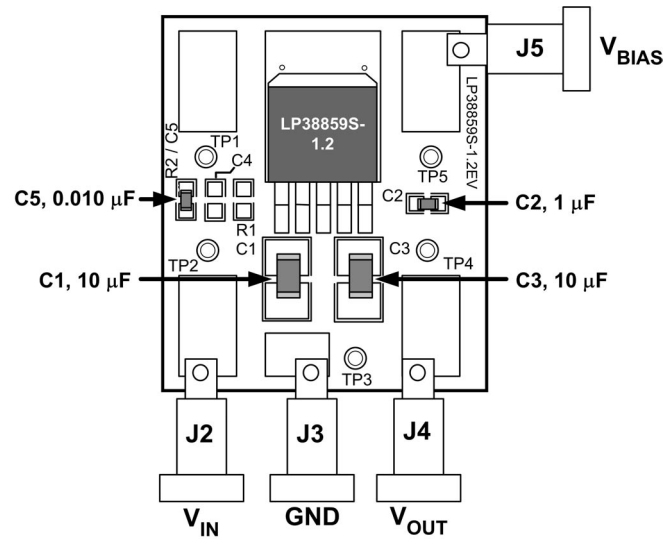

Evaluation Board Component and Pin Layout

20193602

## Power Dissipation

The TO-263 package alone has a junction to ambient thermal resistance ( $\theta_{JA}$ ) rating of  $60^{\circ}\text{C/W}$ . When mounted on the LP38859S evaluation board the  $\theta_{JA}$  rating is approximately  $37^{\circ}\text{C/W}$ .

Although there is only approximately 0.28 square inches of copper area immediately under the tab, the top copper surface area is extended to additional copper area on the bottom of the board by five thermal vias.

With the  $37^{\circ}\text{C/W}$  thermal rating the LP38859S evaluation board will dissipate a maximum of 2.75W with  $T_A = 25^{\circ}\text{C}$ .

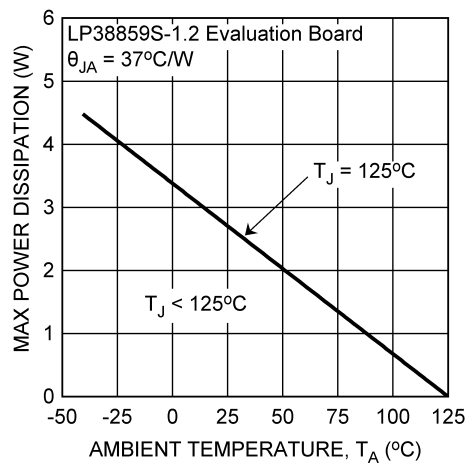

20193606

FIGURE 2. Maximum Power Dissipation vs Ambient Temperature

## Bill of Materials

ID	Name	Description	Manufacturer	Part Number
U1	U1	LP38859S-1.2 NOPB	National Semiconductor Corporation	LP38859S-1.2 NOPB
C1	C <sub>IN</sub>	10 $\mu$ F, 10%, MLCC, 10V, X7R, 1210	AVX	1210ZC106KAT2A
C2	C <sub>BIAS</sub>	1 $\mu$ F, 10%, MLCC, 10V, X7R, 0805	AXV	0805ZC105KAT2A
C3	C <sub>OUT</sub>	10 $\mu$ F, 10%, MLCC, 10V, X7R, 1210	AVX	1210ZC106KAT2A
C4	—	Not Installed	—	—
C5	C <sub>SS</sub>	0.010 $\mu$ F, 10%, MLCC, 16V, X7R, 0805	AVX	0805YC103KAT2A
J1	—	Not Installed	Johnson Components	—
J2	V <sub>IN</sub>	Banana Jack : Insulated Solder Terminal - RED		108-0902-001
J3	GND	Banana Jack : Insulated Solder Terminal - BLACK		108-0903-001
J4	V <sub>OUT</sub>	Banana Jack : Insulated Solder Terminal - ORANGE		108-0906-001
J5	V <sub>BIAS</sub>	Banana Jack : Insulated Solder Terminal - BLUE		108-0910-001
R1	—	Not Installed	—	—
R2	—	Not Installed	—	—
TP1	—	Not Installed	—	—
TP2	TP <sub>IN</sub>	Turret Terminal : Mounting Hole Diameter = 0.062"	Keystone	1593-2
TP3	TP <sub>GND</sub>			
TP4	TP <sub>OUT</sub>			
TP5	TP <sub>BIAS</sub>			

THE CONTENTS OF THIS DOCUMENT ARE PROVIDED IN CONNECTION WITH NATIONAL SEMICONDUCTOR CORPORATION ("NATIONAL") PRODUCTS. NATIONAL MAKES NO REPRESENTATIONS OR WARRANTIES WITH RESPECT TO THE ACCURACY OR COMPLETENESS OF THE CONTENTS OF THIS PUBLICATION AND RESERVES THE RIGHT TO MAKE CHANGES TO SPECIFICATIONS AND PRODUCT DESCRIPTIONS AT ANY TIME WITHOUT NOTICE. NO LICENSE, WHETHER EXPRESS, IMPLIED, ARISING BY ESTOPPEL OR OTHERWISE, TO ANY INTELLECTUAL PROPERTY RIGHTS IS GRANTED BY THIS DOCUMENT.

TESTING AND OTHER QUALITY CONTROLS ARE USED TO THE EXTENT NATIONAL DEEMS NECESSARY TO SUPPORT NATIONAL'S PRODUCT WARRANTY. EXCEPT WHERE MANDATED BY GOVERNMENT REQUIREMENTS, TESTING OF ALL PARAMETERS OF EACH PRODUCT IS NOT NECESSARILY PERFORMED. NATIONAL ASSUMES NO LIABILITY FOR APPLICATIONS ASSISTANCE OR BUYER PRODUCT DESIGN. BUYERS ARE RESPONSIBLE FOR THEIR PRODUCTS AND APPLICATIONS USING NATIONAL COMPONENTS. PRIOR TO USING OR DISTRIBUTING ANY PRODUCTS THAT INCLUDE NATIONAL COMPONENTS, BUYERS SHOULD PROVIDE ADEQUATE DESIGN, TESTING AND OPERATING SAFEGUARDS.

EXCEPT AS PROVIDED IN NATIONAL'S TERMS AND CONDITIONS OF SALE FOR SUCH PRODUCTS, NATIONAL ASSUMES NO LIABILITY WHATSOEVER, AND NATIONAL DISCLAIMS ANY EXPRESS OR IMPLIED WARRANTY RELATING TO THE SALE AND/OR USE OF NATIONAL PRODUCTS INCLUDING LIABILITY OR WARRANTIES RELATING TO FITNESS FOR A PARTICULAR PURPOSE, MERCHANTABILITY, OR INFRINGEMENT OF ANY PATENT, COPYRIGHT OR OTHER INTELLECTUAL PROPERTY RIGHT.

#### LIFE SUPPORT POLICY

**NATIONAL'S PRODUCTS ARE NOT AUTHORIZED FOR USE AS CRITICAL COMPONENTS IN LIFE SUPPORT DEVICES OR SYSTEMS WITHOUT THE EXPRESS PRIOR WRITTEN APPROVAL OF THE CHIEF EXECUTIVE OFFICER AND GENERAL COUNSEL OF NATIONAL SEMICONDUCTOR CORPORATION.** As used herein:

Life support devices or systems are devices which (a) are intended for surgical implant into the body, or (b) support or sustain life and whose failure to perform when properly used in accordance with instructions for use provided in the labeling can be reasonably expected to result in a significant injury to the user. A critical component is any component in a life support device or system whose failure to perform can be reasonably expected to cause the failure of the life support device or system or to affect its safety or effectiveness.

National Semiconductor and the National Semiconductor logo are trademarks or registered trademarks of National Semiconductor Corporation. All other brand or product names may be trademarks or registered trademarks of their respective holders.

Copyright © 2006 National Semiconductor Corporation.

For the most current product information visit us at [www.national.com](http://www.national.com).



**National Semiconductor**  
Americas Customer  
Support Center  
Email: [new.feedback@nsc.com](mailto:new.feedback@nsc.com)  
Tel: 1-800-272-9959

[www.national.com](http://www.national.com)

**National Semiconductor**  
Europe Customer Support Center  
Fax: +49 (0) 180-530 85 86  
Email: [europa.support@nsc.com](mailto:europa.support@nsc.com)  
Deutsch Tel: +49 (0) 69 9508 6208  
English Tel: +44 (0) 870 24 0 2171  
Français Tel: +33 (0) 1 41 91 8790

**National Semiconductor**  
Asia Pacific Customer  
Support Center  
Email: [ap.support@nsc.com](mailto:ap.support@nsc.com)

**National Semiconductor**  
Japan Customer Support Center  
Fax: 81-3-5639-7507  
Email: [jpn.feedback@nsc.com](mailto:jpn.feedback@nsc.com)  
Tel: 81-3-5639-7560