

LM3424 Buck-Boost Evaluation Board

National Semiconductor
Application Note 1967
James Patterson
August 21, 2009



Introduction

This wide range evaluation board showcases the LM3424 NFET controller used with a buck-boost current regulator. It is designed to drive 4 to 10 LEDs at a maximum average LED current of 1A from a DC input voltage of 10 to 70V.

The evaluation board showcases many of the LM3424 features including thermal foldback, analog dimming, external switching frequency synchronization, and high frequency PWM dimming, among others. There are many external connection points to facilitate the full evaluation of the LM3424 device including inputs, outputs and test points. Refer to the table below for a summary of the connectors and test points.

The buck-boost circuit can be easily redesigned for different specifications by changing only a few components (see the *Alternate Designs* section found at the end of this application note). Note that design modifications can change the system efficiency for better or worse.

This application note is designed to be used in conjunction with the LM3424 datasheet as a reference for the LM3424 buck-boost evaluation board. Refer to the LM3424 datasheet for a comprehensive explanation of the device, design procedures, and application information.

Key Features

- Input: 10V to 70V
- Output: 4 to 10 LEDs at 1A
- Thermal Foldback / Analog Dimming
- PWM Dimming up to 10 kHz
- External Synchronization > 500 kHz
- Input Under-voltage and Output Over-voltage Protection

EFFICIENCY WITH 9 SERIES LEDS AT 1A

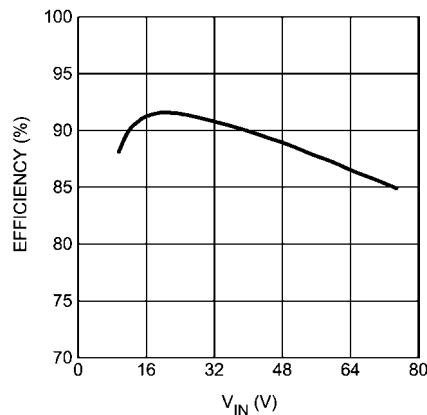

30096881

External Connection Descriptions

Qty	Name	Description	Application Information
J1	V _{IN}	Input Voltage	Connect to positive terminal of supply voltage.
J2	GND	Input Ground	Connect to negative terminal of supply voltage (GND).
J3	EN	Enable On/Off	Jumper connected enables device.
J4	LED+	LED Positive	Connect to anode (top) of LED string.
J5	LED-	LED Negative	Connect to cathode (bottom) of LED string.
J6	BNC	Dimming Input	Connect a 3V to 10V PWM input signal up to 10 kHz for PWM dimming the LED load.
J7	OUT	Output with NTC	Alternative connector for LED+ and LED-. Pins 4 and 11 are used for connecting an external NTC thermistor. Refer to schematic for detailed connectivity.
TP1	SW	Switch Node Voltage	Test point for switch node (where Q1, D1, and L1 connect).
TP3	SGND	Signal Ground	Connection for GND when applying signals to TP5, TP8, and TP9.
TP4	LED+	LED Positive Voltage	Test point for anode (top) of LED string.
TP5	nDIM	Inverted Dim Signal	Test point for dimming input (inverted from input signal).
TP6	V _{IN}	Input Voltage	Test point for input voltage.
TP8	SYNC	Synchronization Input	Connect a 3V to 6V PWM clock signal > 500 kHz (pulse width of 100ns) to synchronize the LM3424 switching frequency to the external clock.
TP9	NTC	Temp Sense Input	Connect a 0V to 1.24V DC voltage to analog dim the LED current.
TP10	PGND	Power Ground	Test point for GND when monitoring TP1, TP4, or TP6.

Schematic

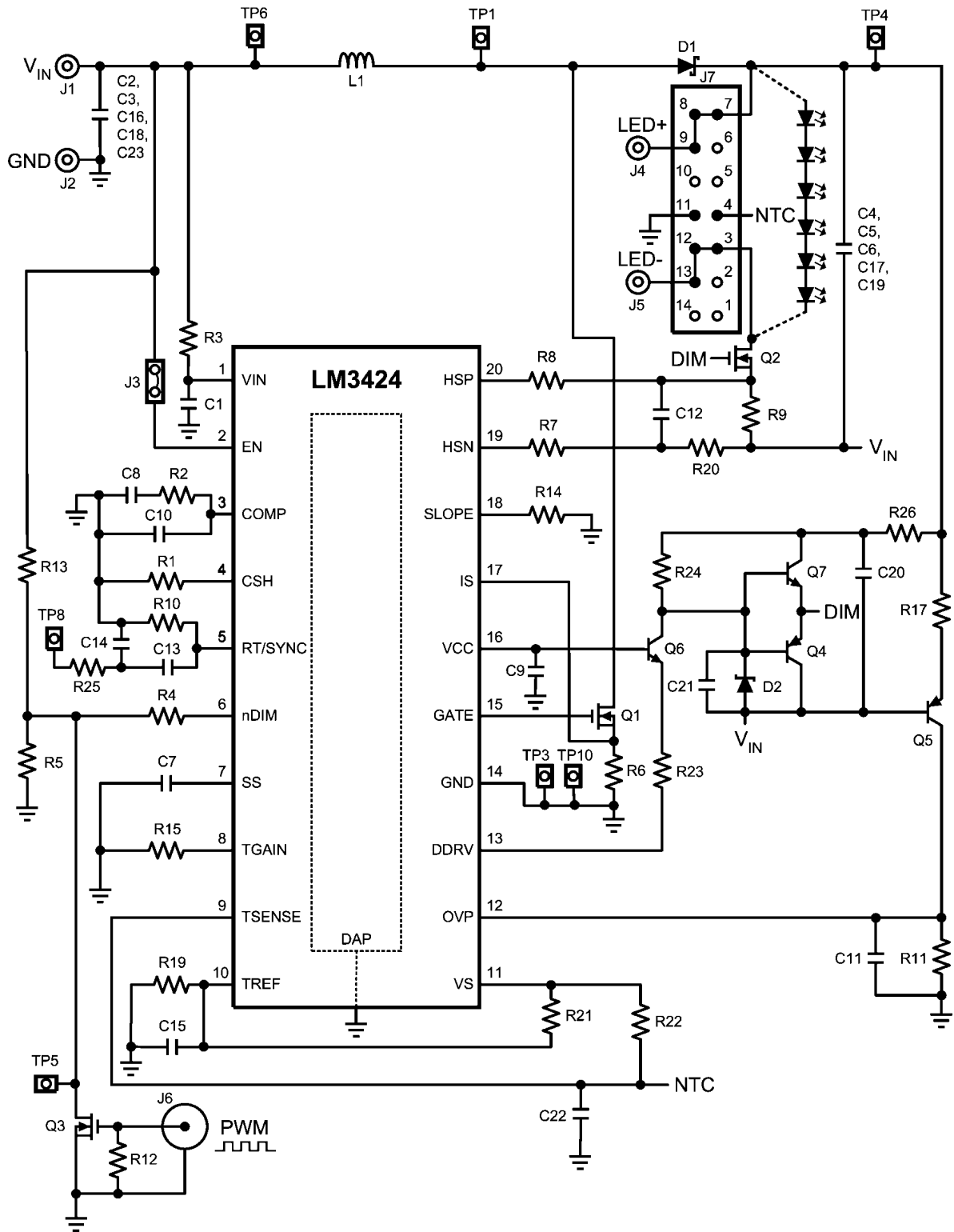

30096880

LM3424 Pin Descriptions

Pin	Name	Description	Application Information
1	V _{IN}	Input Voltage	Bypass with 100 nF capacitor to GND as close to the device as possible in the circuit board layout.
2	EN	Enable	Connect to > 2.4V to enable the device or to < 0.8V for low power shutdown.
3	COMP	Compensation	Connect a capacitor to GND to compensate control loop.
4	CSH	Current Sense High	Connect a resistor to GND to set the signal current. Can also be used to analog dim as explained in the <i>Thermal Foldback / Analog Dimming</i> section of the datasheet.
5	RT	Resistor Timing	Connect a resistor to GND to set the switching frequency. Can also be used to synchronize external clock as explained in the <i>Switching Frequency</i> section of the datasheet.
6	nDIM	Not DIM input	Connect a PWM signal for dimming as detailed in the <i>PWM Dimming</i> section of the datasheet and/or a resistor divider from V _{IN} to program input under-voltage lockout (UVLO). Turn-on threshold is 1.24V and hysteresis for turn-off is provided by 20 μA current source.
7	SS	Soft-start	Connect a capacitor to GND to extend start-up time.
8	TGAIN	Temperature Foldback Gain	Connect a resistor to GND to set the foldback slope.
9	TSENSE	Temperature Sense Input	Connect a resistor/ thermistor divider from V _S to sense the temperature as explained in the <i>Thermal Foldback / Analog Dimming</i> section of the datasheet.
10	TREF	Temperature Foldback Reference	Connect a resistor divider from V _S to set the temperature foldback reference voltage.
11	V _S	Voltage Reference	2.45V reference for temperature foldback circuit and other external circuitry.
12	OVP	Over-Voltage Protection	Connect to a resistor divider from V _O to program output over-voltage lockout (OVLO). Turn-off threshold is 1.24V and hysteresis for turn-on is provided by 20 μA current source.
13	DDRV	Dimming Gate Drive Output	Connect to gate of dimming MosFET.
14	GND	Ground	Connect to DAP to provide proper system GND
15	GATE	Gate Drive Output	Connect to gate of main switching MosFET.
16	V _{CC}	Internal Regulator Output	Bypass with a 2.2 μF–3.3 μF, ceramic capacitor to GND.
17	IS	Main Switch Current Sense	Connect to the drain of the main N-channel MosFET switch for R _{DS-ON} sensing or to a sense resistor installed in the source of the same device.
18	SLOPE	Slope Compensation	Connect a resistor to GND to set slope of additional ramp.
19	HSN	High-Side LED Current Sense Negative	Connect through a series resistor to the negative side of the LED current sense resistor.
20	HSP	High-Side LED Current Sense Positive	Connect through a series resistor to the positive side of the LED current sense resistor.
DAP (21)	DAP	Thermal pad on bottom of IC	Connect to GND and place 6 - 9 vias to bottom layer ground pour.

Bill of Materials

Qty	Part ID	Part Value	Manufacturer	Part Number
4	C1, C5, C20, C23	0.1 μ F X7R 10% 100V	TDK	C2012X7R2A104K
4	C2, C3, C16, C18	4.7 μ F X7R 10% 100V	TDK	C5750X7R2A475K
4	C4, C6, C17, C19	10 μ F X7R 10% 50V	TDK	C5750X7R1H106K
2	C7, C22	0.47 μ F X7R 10% 16V	MURATA	GRM21BR71C474KA01L
0	C8	DNP		
1	C9	2.2 μ F X7R 10% 16V	MURATA	GRM21BR71C225KA12L
1	C10	1 μ F X7R 10% 16V	MURATA	GRM21BR71C105KA01L
1	C11	47 pF COG/NPO 5% 50V	AVX	08055A470JAT2A
1	C12	0.22 μ F X7R 10% 16V	MURATA	GRM219R71C224KA01D
3	C13, C14, C21	100 pF COG/NPO 5% 50V	MURATA	GRM2165C1H101JA01D
1	C15	1 μ F X7R 10% 16V	MURATA	GRM21BR71C105MA01L
1	D1	Schottky 100V 12A	VISHAY	12CWQ10FNPBF
1	D2	Zener 10V	ON-SEMI	BZX84C10LT1G
4	J1, J2, J4, J5	Banana Jack	KEYSTONE	575-8
1	J3	1x2 Header Male	SAMTEC	TSW-102-07-T-S
1	J6	BNC connector	AMPHENOL	112536
1	J7	2x7 Header Male Shrouded RA	SAMTEC	TSSH-107-01-SDRA
1	L1	33 μ H 20% 6.3A	COILCRAFT	MSS1278-333MLB
2	Q1, Q2	NMOS 100V 32A	FAIRCHILD	FDD3682
1	Q3	NMOS 60V 260mA	ON-SEMI	2N7002ET1G
1	Q4	PNP 40V 200mA	FAIRCHILD	MMBT5087
1	Q5	PNP 150V 600 mA	FAIRCHILD	MMBT5401
1	Q6	NPN 300V 600mA	FAIRCHILD	MMBTA42
1	Q7	NPN 40V 200mA	FAIRCHILD	MMBT6428
2	R1, R11	12.4 k Ω 1%	VISHAY	CRCW080512K4FKEA
0	R2	DNP		
3	R3, R20, R26	10 Ω 1%	VISHAY	CRCW080510R0FKEA
1	R4	17.4 k Ω 1%	VISHAY	CRCW080517K4FKEA
1	R5	1.43 k Ω 1%	VISHAY	CRCW08051K43FKEA
1	R6	0.04 Ω 1% 1W	VISHAY	WSL2512R0400FEA
2	R7, R8	1.0 k Ω 1%	VISHAY	CRCW08051K00FKEA
1	R9	0.1 Ω 1% 1W	VISHAY	WSL2512R1000FEA
1	R10	14.3 k Ω 1%	VISHAY	CRCW080514K3FKEA
4	R12, R13, R14, R15	10.0 k Ω 1%	VISHAY	CRCW080510K0FKEA
1	R17	499 k Ω 1%	VISHAY	CRCW0805499KFKEA
3	R19, R21, R22	49.9 k Ω 1%	VISHAY	CRCW080549K9FKEA
1	R23	499 Ω 1%	VISHAY	CRCW0805499RFKEA
1	R24	4.99 k Ω 1%	VISHAY	CRCW08054K99FKEA
1	R25	150 Ω 1%	VISHAY	CRCW0805150RFKEA
8	TP1, TP3, TP4, TP5, TP6, TP8, TP9, TP10	Turret	Keystone	1502-2
1	U1	Buck-boost controller	NSC	LM3424MH

PCB Layout

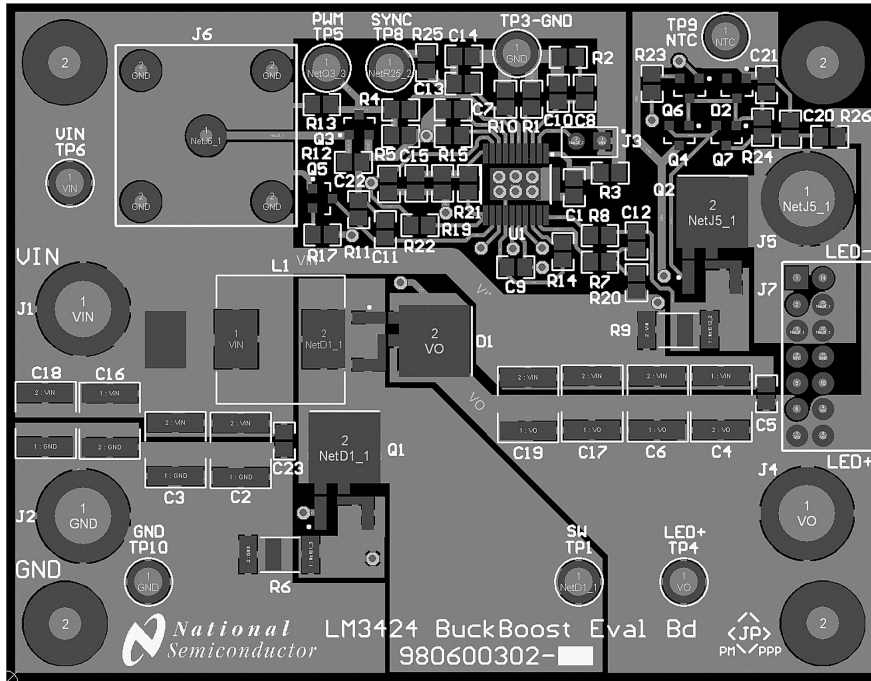

Top Layer

30096884

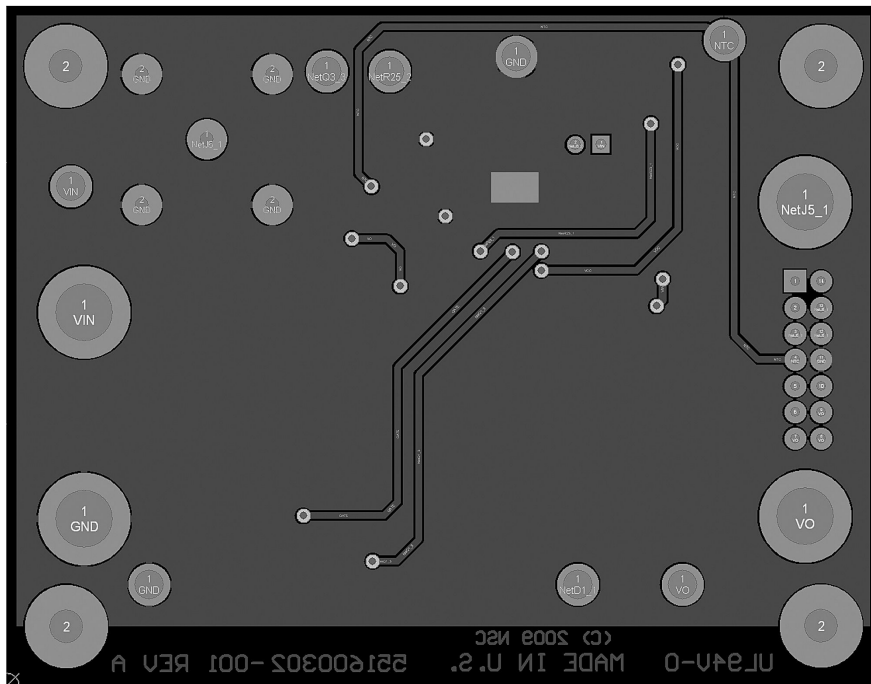

Bottom Layer

30096885

Design Procedure

SPECIFICATIONS

$N = 6$
 $V_{LED} = 3.5V$
 $r_{LED} = 325 \text{ m}\Omega$
 $V_{IN} = 24V$
 $V_{IN-MIN} = 10V$
 $V_{IN-MAX} = 70V$
 $f_{SW} = 500 \text{ kHz}$
 $V_{SNS} = 100 \text{ mV}$
 $I_{LED} = 1A$
 $\Delta i_{L-PP} = 700 \text{ mA}$
 $\Delta i_{LED-PP} = 12 \text{ mA}$
 $\Delta V_{IN-PP} = 100 \text{ mV}$
 $I_{LIM} = 6A$
 $V_{TURN-ON} = 10V$
 $V_{HYS} = 3V$
 $V_{TURN-OFF} = 50V$
 $V_{HYSO} = 10V$
 $T_{BK} = 45^\circ\text{C}$
 $T_{END} = 125^\circ\text{C}$
 $t_{TSU} = 40 \text{ ms}$

1. OPERATING POINT

Solve for V_O and r_D :

$$V_O = N \times V_{LED} = 6 \times 3.5V = 21V$$

$$r_D = N \times r_{LED} = 6 \times 325 \text{ m}\Omega = 1.95\Omega$$

Solve for D , D' , D_{MAX} , and D_{MIN} :

$$D = \frac{V_O}{V_O + V_{IN}} = \frac{21V}{21V + 24V} = 0.467$$

$$D' = 1 - D = 1 - 0.467 = 0.533$$

$$D_{MIN} = \frac{V_O}{V_O + V_{IN-MAX}} = \frac{21V}{21V + 70V} = 0.231$$

$$D_{MAX} = \frac{V_O}{V_O + V_{IN-MIN}} = \frac{21V}{21V + 10V} = 0.677$$

2. SWITCHING FREQUENCY

Solve for R_T :

$$R_{T10} = \frac{1 + 1.95e^{-8} \times f_{SW}}{1.40e^{-10} \times f_{SW}} = \frac{1 + 1.95e^{-8} \times 500 \text{ kHz}}{1.40e^{-10} \times 500 \text{ kHz}} = 14.4 \text{ k}\Omega$$

The closest standard resistor is 14.3 k Ω therefore f_{SW} is:

$$f_{SW} = \frac{1}{1.40e^{-10} \times R_{T10} - 1.95e^{-8}}$$

$$f_{SW} = \frac{1}{1.40e^{-10} \times 14.3 \text{ k}\Omega - 1.95e^{-8}} = 504 \text{ kHz}$$

The chosen component from step 2 is:

$$R_{T10} = 14.3 \text{ k}\Omega$$

3. AVERAGE LED CURRENT

Solve for R_{SNS} :

$$R_9 = \frac{V_{SNS}}{I_{LED}} = \frac{100 \text{ mV}}{1A} = 0.1\Omega$$

Assume $R_{CSH} = 12.4 \text{ k}\Omega$ and solve for R_{HSP} :

$$R_8 = \frac{I_{LED} \times R_1 \times R_9}{1.24V} = \frac{1A \times 12.4 \text{ k}\Omega \times 0.1\Omega}{1.24V} = 1.0 \text{ k}\Omega$$

The closest standard resistor for R_{SNS} is actually 0.1 Ω and for R_{HSP} is actually 1 k Ω therefore I_{LED} is:

$$I_{LED} = \frac{1.24V \times R_8}{R_9 \times R_1} = \frac{1.24V \times 1.0 \text{ k}\Omega}{0.1\Omega \times 12.4 \text{ k}\Omega} = 1.0A$$

The chosen components from step 3 are:

$$\begin{aligned}
 R_9 &= 0.1\Omega \\
 R_1 &= 12.4 \text{ k}\Omega \\
 R_8 &= R_7 = 1 \text{ k}\Omega
 \end{aligned}$$

4. THERMAL FOLDBACK

Using a standard 100k NTC thermistor (connected to pins 4 and 11 of J7), find the resistances corresponding to T_{BK} and T_{END} ($R_{NTC-BK} = 243 \text{ k}\Omega$ and $R_{NTC-END} = 71.5 \text{ k}\Omega$) from the manufacturer's datasheet. Assuming $R_{REF1} = R_{REF2} = 49.9 \text{ k}\Omega$, then $R_{BIAS} = R_{NTC-BK} = 243 \text{ k}\Omega$.

Solve for R_{GAIN} :

$$R_{GAIN} = \frac{\left(\frac{R_{19}}{R_{19} + R_{21}} - \frac{R_{NTC-END}}{R_{NTC-END} + R_{22}} \right) \times 2.45V}{I_{CSH}}$$

$$R_{GAIN} = \frac{\left(\frac{1}{2} - \frac{6.34 \text{ k}\Omega}{6.34 \text{ k}\Omega + 49.9 \text{ k}\Omega} \right) \times 2.45V}{100 \mu\text{A}} = 9.49 \text{ k}\Omega$$

The chosen components from step 4 are:

$$\begin{aligned}
 R_{15} &= 10 \text{ k}\Omega \\
 R_{19} &= R_{21} = R_{22} = 49.9 \text{ k}\Omega
 \end{aligned}$$

5. INDUCTOR RIPPLE CURRENT

Solve for L1:

$$L1 = \frac{V_{IN} \times D}{\Delta i_{L-PP} \times f_{SW}} = \frac{24V \times 0.467}{700 \text{ mA} \times 504 \text{ kHz}} = 32 \mu\text{H}$$

The closest standard inductor is 33 μH therefore Δi_{L-PP} is:

$$\Delta i_{L-PP} = \frac{V_{IN} \times D}{L1 \times f_{SW}} = \frac{24V \times 0.467}{33 \mu\text{H} \times 504 \text{ kHz}} = 674 \text{ mA}$$

Determine minimum allowable RMS current rating:

$$I_{L-RMS} = \frac{I_{LED}}{D'} \times \sqrt{1 + \frac{1}{12} \times \left(\frac{\Delta i_{L-PP} \times D'}{I_{LED}} \right)^2}$$

$$I_{L-RMS} = \frac{1A}{0.533} \times \sqrt{1 + \frac{1}{12} \times \left(\frac{674 \text{ mA} \times 0.533}{1A} \right)^2} = 1.89A$$

The chosen component from step 5 is:

$$L1 = 33 \mu\text{H}$$

6. OUTPUT CAPACITANCE

Solve for C_O:

$$C_O = \frac{I_{LED} \times D}{r_D \times \Delta i_{LED-PP} \times f_{SW}}$$

$$C_O = \frac{1A \times 0.467}{1.95\Omega \times 12 \text{ mA} \times 504 \text{ kHz}} = 39.6 \mu\text{F}$$

The closest capacitance totals 40 μF therefore Δi_{LED-PP} is:

$$\Delta i_{LED-PP} = \frac{I_{LED} \times D}{r_D \times C_O \times f_{SW}}$$

$$\Delta i_{LED-PP} = \frac{1A \times 0.467}{1.95\Omega \times 40 \mu\text{F} \times 504 \text{ kHz}} = 12 \text{ mA}$$

Determine minimum allowable RMS current rating:

$$I_{CO-RMS} = I_{LED} \times \sqrt{\frac{D_{MAX}}{1 - D_{MAX}}} = 1A \times \sqrt{\frac{0.677}{1 - 0.677}} = 1.45A$$

The chosen components from step 6 are:

$$C4 = C6 = C17 = C19 = 10 \mu\text{F}$$

7. PEAK CURRENT LIMIT

Solve for R_{LIM}:

$$R6 = \frac{245 \text{ mV}}{I_{LIM}} = \frac{245 \text{ mV}}{6A} = 0.041\Omega$$

The closest standard resistor is 0.04 Ω therefore I_{LIM} is:

$$I_{LIM} = \frac{245 \text{ mV}}{R6} = \frac{245 \text{ mV}}{0.04\Omega} = 6.13A$$

The chosen component from step 7 is:

$$R6 = 0.04\Omega$$

8. SLOPE COMPENSATION

Solve for R_{SLP}:

$$R15 = \frac{1.5e^{13} \times L1}{V_O \times R10 \times R9}$$

$$R15 = \frac{1.5e^{13} \times 33 \mu\text{H}}{35V \times 14.3 \text{ k}\Omega \times 0.1\Omega} = 9.9 \text{ k}\Omega$$

The chosen component from step 8 is:

$$R_{SLP} = 10 \text{ k}\Omega$$

9. LOOP COMPENSATION

ω_{P1} is approximated:

$$\omega_{P1} = \frac{1 + D}{r_D \times C_O} = \frac{1.467}{1.95\Omega \times 40 \mu\text{F}} = 19 \text{ k} \frac{\text{rad}}{\text{sec}}$$

ω_{Z1} is approximated:

$$\omega_{Z1} = \frac{r_D \times D'^2}{D \times L1} = \frac{1.95\Omega \times 0.533^2}{0.467 \times 33 \mu\text{H}} = 36 \text{ k} \frac{\text{rad}}{\text{sec}}$$

T_{U0} is approximated:

$$T_{U0} = \frac{D' \times 620V}{(1 + D) \times I_{LED} \times R6} = \frac{0.533 \times 620V}{1.467 \times 1A \times 0.04\Omega} = 5630$$

To ensure stability, calculate ω_{P2} :

$$\omega_{P2} = \frac{\min(\omega_{P1}, \omega_{Z1})}{5 \times T_{U0}} = \frac{\omega_{Z1}}{5 \times 5630} = \frac{19 \text{ k} \frac{\text{rad}}{\text{sec}}}{5 \times 5630} = 0.675 \frac{\text{rad}}{\text{sec}}$$

Solve for C_{COMP}:

$$C10 = \frac{1}{\omega_{P2} \times 5e^6\Omega} = \frac{1}{0.675 \frac{\text{rad}}{\text{sec}} \times 5e^6\Omega} = 0.30 \mu\text{F}$$

To attenuate switching noise, calculate ω_{P3} :

$$\omega_{P3} = (\max(\omega_{P1}, \omega_{Z1})) \times 10 = \omega_{P1} \times 10$$

$$\omega_{P3} = 36 \text{ k} \frac{\text{rad}}{\text{sec}} \times 10 = 360 \text{ k} \frac{\text{rad}}{\text{sec}}$$

Assume $R_{FS} = 10\Omega$ and solve for C_{FS} :

$$C_{12} = \frac{1}{10\Omega \times \omega_{P3}} = \frac{1}{10\Omega \times 360k \frac{\text{rad}}{\text{sec}}} = 0.28 \mu\text{F}$$

The chosen components from step 9 are:

$$\begin{aligned} C_{10} &= 1 \mu\text{F} \\ R_{20} &= 10\Omega \\ C_{12} &= 0.22 \mu\text{F} \end{aligned}$$

10. INPUT CAPACITANCE

Solve for the minimum C_{IN} :

$$C_{IN} = \frac{I_{LED} \times D}{\Delta V_{IN-PP} \times f_{SW}} = \frac{1\text{A} \times 0.467}{100\text{mV} \times 504\text{kHz}} = 9.27 \mu\text{F}$$

To minimize power supply interaction a 200% larger capacitance of approximately 20 μF is used, therefore the actual ΔV_{IN-PP} is much lower. Since high voltage ceramic capacitor selection is limited, four 4.7 μF X7R capacitors are chosen.

Determine minimum allowable RMS current rating:

$$I_{IN-RMS} = I_{LED} \times \sqrt{\frac{D_{MAX}}{1 - D_{MAX}}} = 1\text{A} \times \sqrt{\frac{0.677}{1 - 0.677}} = 1.45\text{A}$$

The chosen components from step 10 are:

$$C_2 = C_3 = C_{16} = C_{18} = 4.7 \mu\text{F}$$

11. NFET

Determine minimum Q1 voltage rating and current rating:

$$V_{T-MAX} = V_{IN-MAX} + V_O = 70\text{V} + 21\text{V} = 91\text{V}$$

$$I_{T-MAX} = \frac{0.677}{1 - 0.677} \times 1\text{A} = 2.1\text{A}$$

A 100V NFET is chosen with a current rating of 32A due to the low $R_{DS-ON} = 50\text{m}\Omega$. Determine I_{T-RMS} and P_T :

$$I_{T-RMS} = \frac{I_{LED}}{D'} \times \sqrt{D} = \frac{1\text{A}}{0.533} \times \sqrt{0.467} = 1.28\text{A}$$

$$P_T = I_{T-RMS}^2 \times R_{DS-ON} = 1.28\text{A}^2 \times 50\text{m}\Omega = 82\text{mW}$$

The chosen component from step 11 is:

$$Q_1 \rightarrow 32\text{A}, 100\text{V}, \text{DPAK}$$

12. DIODE

Determine minimum D1 voltage rating and current rating:

$$V_{RD-MAX} = V_{IN-MAX} + V_O = 70\text{V} + 21\text{V} = 91\text{V}$$

$$I_{D-MAX} = I_{LED} = 1\text{A}$$

A 100V diode is chosen with a current rating of 12A and $V_D = 600\text{mV}$. Determine P_D :

$$P_D = I_D \times V_{FD} = 1\text{A} \times 600\text{mV} = 600\text{mW}$$

The chosen component from step 12 is:

$$D_1 \rightarrow 12\text{A}, 100\text{V}, \text{DPAK}$$

13. INPUT UVLO

Solve for R_{UV2} :

$$R_4 = \frac{R_5 \times (V_{HYS} - 20 \mu\text{A} \times R_{13})}{20 \mu\text{A} \times (R_5 + R_{13})}$$

$$R_4 = \frac{1.43\text{k}\Omega \times (3\text{V} - 20 \mu\text{A} \times 10\text{k}\Omega)}{20 \mu\text{A} \times (1.43\text{k}\Omega + 10\text{k}\Omega)} = 17.5\text{k}\Omega$$

The closest standard resistor is 150 $\text{k}\Omega$ therefore V_{HYS} is:

$$V_{HYS} = \frac{20 \mu\text{A} \times R_4 \times (R_5 + R_{13})}{R_5} + 20 \mu\text{A} \times R_{13}$$

$$V_{HYS} = \frac{20 \mu\text{A} \times 17.4\text{k}\Omega \times (1.43\text{k}\Omega + 10\text{k}\Omega)}{1.43\text{k}\Omega} + 20 \mu\text{A} \times 10\text{k}\Omega = 2.98\text{V}$$

Solve for R_{UV1} :

$$R_5 = \frac{1.24\text{V} \times R_{13}}{V_{TURN-ON} - 1.24\text{V}} = \frac{1.24\text{V} \times 10\text{k}\Omega}{10\text{V} - 1.24\text{V}} = 1.42\text{k}\Omega$$

The closest standard resistor is 21 $\text{k}\Omega$ making $V_{TURN-ON}$:

$$V_{TURN-ON} = \frac{1.24\text{V} \times (R_5 + R_{13})}{R_5}$$

$$V_{TURN-ON} = \frac{1.24\text{V} \times (1.43\text{k}\Omega + 10\text{k}\Omega)}{1.43\text{k}\Omega} = 9.91\text{V}$$

The chosen components from step 13 are:

$$\begin{aligned} R_5 &= 1.43\text{k}\Omega \\ R_{13} &= 10\text{k}\Omega \\ R_4 &= 17.4\text{k}\Omega \end{aligned}$$

14. OUTPUT OVLO

Solve for R_{OV2} :

$$R17 = \frac{V_{HYSO}}{20 \mu A} = \frac{10V}{20 \mu A} = 500 \text{ k}\Omega$$

The closest standard resistor is 499 k Ω therefore V_{HYSO} is:

$$V_{HYSO} = R17 \times 20 \mu A = 499 \text{ k}\Omega \times 20 \mu A = 9.98V$$

Solve for R_{OV1} :

$$R11 = \frac{1.24V \times R17}{V_{TURN-OFF} - 1.24V} = \frac{1.24V \times 499 \text{ k}\Omega}{50V - 620 \text{ mV}} = 12.5 \text{ k}\Omega$$

The closest standard resistor is 15.8 k Ω making $V_{TURN-OFF}$:

$$V_{TURN-OFF} = \frac{1.24V \times (R11 + R17)}{R11}$$

$$V_{TURN-OFF} = \frac{1.24V \times (12.4 \text{ k}\Omega + 499 \text{ k}\Omega)}{12.4 \text{ k}\Omega} = 51.1V$$

The chosen components from step 14 are:

$$\begin{array}{l} R11 = 12.4 \text{ k}\Omega \\ R17 = 499 \text{ k}\Omega \end{array}$$

15. SOFT-START

Solve for t_{SU} :

$$t_{SU} = 168\Omega \times C9 + 36 \text{ k}\Omega \times C10 + \frac{V_O}{I_{LED}} \times C_O$$

$$t_{SU} = 168\Omega \times 2.2 \mu F + 36 \text{ k}\Omega \times 1.0 \mu F + \frac{21V}{1A} \times 40 \mu F$$

$$t_{SU} = 37.2 \text{ ms}$$

If t_{SU} is less than t_{TSU} , solve for $t_{SU-SS-BASE}$:

$$t_{SU-SS-BASE} = 168\Omega \times C9 + 28 \text{ k}\Omega \times C10 + \frac{V_O}{I_{LED}} \times C_O$$

$$t_{SU-SS-BASE} = 168\Omega \times 2.2 \mu F + 28 \text{ k}\Omega \times 1.0 \mu F + \frac{21V}{1A} \times 40 \mu F$$

$$t_{SU-SS-BASE} = 29.2 \text{ ms}$$

Solve for C_{SS} :

$$C_{SS} = \frac{(t_{TSU} - t_{SU-SS-BASE})}{20 \text{ k}\Omega} = \frac{(40 \text{ ms} - 29.2 \text{ ms})}{20 \text{ k}\Omega} = 540 \text{ nF}$$

The chosen component from step 15 is:

$$C_{SS} = 0.47 \mu F$$

Typical Waveforms

$T_A = +25^\circ\text{C}$, $V_{IN} = 24V$ and $V_O = 21V$.

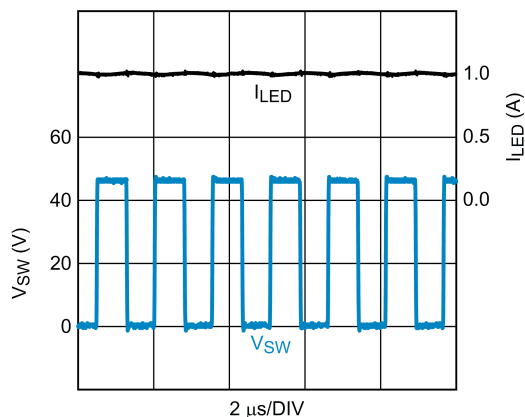

STANDARD OPERATION
TP1 switch node voltage (V_{SW})
LED current (I_{LED})

30096882

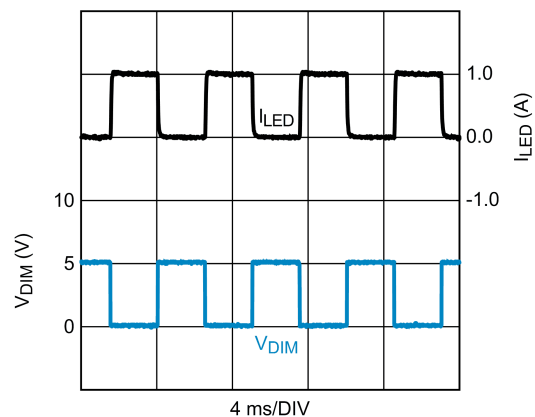

200Hz 50% PWM DIMMING
TP5 dim voltage (V_{DIM})
LED current (I_{LED})

30096883

Alternate Designs

Alternate designs with the LM3429 evaluation board are possible with very few changes to the existing hardware. The evaluation board FETs and diodes are already rated higher than necessary for design flexibility. The input UVLO, output OVP, input and output capacitance can remain the same for

the designs shown below. These alternate designs can be evaluated by changing only R9, R10, and L1.

The table below gives the main specifications for four different designs and the corresponding values for R9, R10, and L1. PWM dimming can be evaluated with any of these designs.

Specification / Component	Design 1	Design 2	Design 3	Design 4
V_{IN}	10V - 45V	15V - 50V	20V - 55V	25V - 60V
V_O	14V	21V	28V	35V
f_{SW}	600kHz	700kHz	500kHz	700kHz
I_{LED}	2A	500mA	2.5A	1.25A
R9	0.05 Ω	0.2 Ω	0.04 Ω	0.08 Ω
R10	12.1 k Ω	10.2 k Ω	14.3 k Ω	10.2 k Ω
L1	22 μ H	68 μ H	15 μ H	33 μ H

Notes

For more National Semiconductor product information and proven design tools, visit the following Web sites at:

Products		Design Support	
Amplifiers	www.national.com/amplifiers	WEBENCH® Tools	www.national.com/webench
Audio	www.national.com/audio	App Notes	www.national.com/appnotes
Clock and Timing	www.national.com/timing	Reference Designs	www.national.com/refdesigns
Data Converters	www.national.com/adc	Samples	www.national.com/samples
Interface	www.national.com/interface	Eval Boards	www.national.com/evalboards
LVDS	www.national.com/lvds	Packaging	www.national.com/packaging
Power Management	www.national.com/power	Green Compliance	www.national.com/quality/green
Switching Regulators	www.national.com/switchers	Distributors	www.national.com/contacts
LDOs	www.national.com/lido	Quality and Reliability	www.national.com/quality
LED Lighting	www.national.com/led	Feedback/Support	www.national.com/feedback
Voltage Reference	www.national.com/vref	Design Made Easy	www.national.com/easy
PowerWise® Solutions	www.national.com/powerwise	Solutions	www.national.com/solutions
Serial Digital Interface (SDI)	www.national.com/sdi	Mil/Aero	www.national.com/milaero
Temperature Sensors	www.national.com/tempensors	SolarMagic™	www.national.com/solarmagic
Wireless (PLL/VCO)	www.national.com/wireless	PowerWise® Design University	www.national.com/training

THE CONTENTS OF THIS DOCUMENT ARE PROVIDED IN CONNECTION WITH NATIONAL SEMICONDUCTOR CORPORATION ("NATIONAL") PRODUCTS. NATIONAL MAKES NO REPRESENTATIONS OR WARRANTIES WITH RESPECT TO THE ACCURACY OR COMPLETENESS OF THE CONTENTS OF THIS PUBLICATION AND RESERVES THE RIGHT TO MAKE CHANGES TO SPECIFICATIONS AND PRODUCT DESCRIPTIONS AT ANY TIME WITHOUT NOTICE. NO LICENSE, WHETHER EXPRESS, IMPLIED, ARISING BY ESTOPPEL OR OTHERWISE, TO ANY INTELLECTUAL PROPERTY RIGHTS IS GRANTED BY THIS DOCUMENT.

TESTING AND OTHER QUALITY CONTROLS ARE USED TO THE EXTENT NATIONAL DEEMS NECESSARY TO SUPPORT NATIONAL'S PRODUCT WARRANTY. EXCEPT WHERE MANDATED BY GOVERNMENT REQUIREMENTS, TESTING OF ALL PARAMETERS OF EACH PRODUCT IS NOT NECESSARILY PERFORMED. NATIONAL ASSUMES NO LIABILITY FOR APPLICATIONS ASSISTANCE OR BUYER PRODUCT DESIGN. BUYERS ARE RESPONSIBLE FOR THEIR PRODUCTS AND APPLICATIONS USING NATIONAL COMPONENTS. PRIOR TO USING OR DISTRIBUTING ANY PRODUCTS THAT INCLUDE NATIONAL COMPONENTS, BUYERS SHOULD PROVIDE ADEQUATE DESIGN, TESTING AND OPERATING SAFEGUARDS.

EXCEPT AS PROVIDED IN NATIONAL'S TERMS AND CONDITIONS OF SALE FOR SUCH PRODUCTS, NATIONAL ASSUMES NO LIABILITY WHATSOEVER, AND NATIONAL DISCLAIMS ANY EXPRESS OR IMPLIED WARRANTY RELATING TO THE SALE AND/OR USE OF NATIONAL PRODUCTS INCLUDING LIABILITY OR WARRANTIES RELATING TO FITNESS FOR A PARTICULAR PURPOSE, MERCHANTABILITY, OR INFRINGEMENT OF ANY PATENT, COPYRIGHT OR OTHER INTELLECTUAL PROPERTY RIGHT.

LIFE SUPPORT POLICY

NATIONAL'S PRODUCTS ARE NOT AUTHORIZED FOR USE AS CRITICAL COMPONENTS IN LIFE SUPPORT DEVICES OR SYSTEMS WITHOUT THE EXPRESS PRIOR WRITTEN APPROVAL OF THE CHIEF EXECUTIVE OFFICER AND GENERAL COUNSEL OF NATIONAL SEMICONDUCTOR CORPORATION. As used herein:

Life support devices or systems are devices which (a) are intended for surgical implant into the body, or (b) support or sustain life and whose failure to perform when properly used in accordance with instructions for use provided in the labeling can be reasonably expected to result in a significant injury to the user. A critical component is any component in a life support device or system whose failure to perform can be reasonably expected to cause the failure of the life support device or system or to affect its safety or effectiveness.

National Semiconductor and the National Semiconductor logo are registered trademarks of National Semiconductor Corporation. All other brand or product names may be trademarks or registered trademarks of their respective holders.

Copyright© 2009 National Semiconductor Corporation

For the most current product information visit us at www.national.com



**National Semiconductor
Americas Technical
Support Center**
Email: support@nsc.com
Tel: 1-800-272-9959

**National Semiconductor Europe
Technical Support Center**
Email: europe.support@nsc.com

**National Semiconductor Asia
Pacific Technical Support Center**
Email: ap.support@nsc.com

**National Semiconductor Japan
Technical Support Center**
Email: jpn.feedback@nsc.com