

LM3429 Buck-Boost Evaluation Board

National Semiconductor
 Application Note 1985
 James Patterson
 August 3, 2009



Introduction

This wide range evaluation board showcases the LM3429 NFET controller used with a buck-boost current regulator. It is designed to drive 4 to 8 LEDs at a maximum average LED current of 1A from a DC input voltage of 10 to 70V.

The evaluation board showcases most features of the LM3429 including PWM dimming, overvoltage protection and input under-voltage lockout. It also has a right angle connector (J7) which can mate with an external LED load board allowing for the LEDs to be mounted close to the driver. Alternatively, the LED+ and LED- banana jacks can be used to connect the LED load.

The buck-boost circuit can be easily redesigned for different specifications by changing only a few components (see the *Alternate Designs* section found at the end of this application note). Note that design modifications can change the system efficiency for better or worse. See the LM3429 datasheet for a comprehensive explanation of the device and application information.

EFFICIENCY WITH 6 SERIES LEDs AT 1A

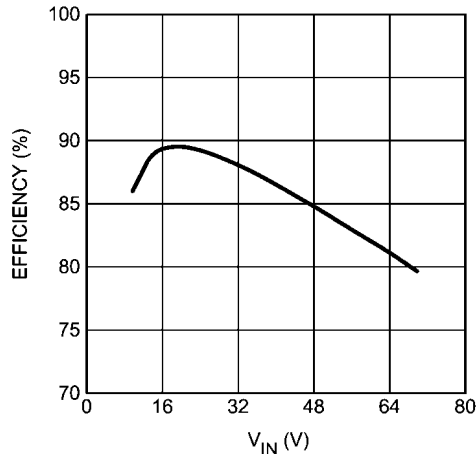

30100801

Schematic

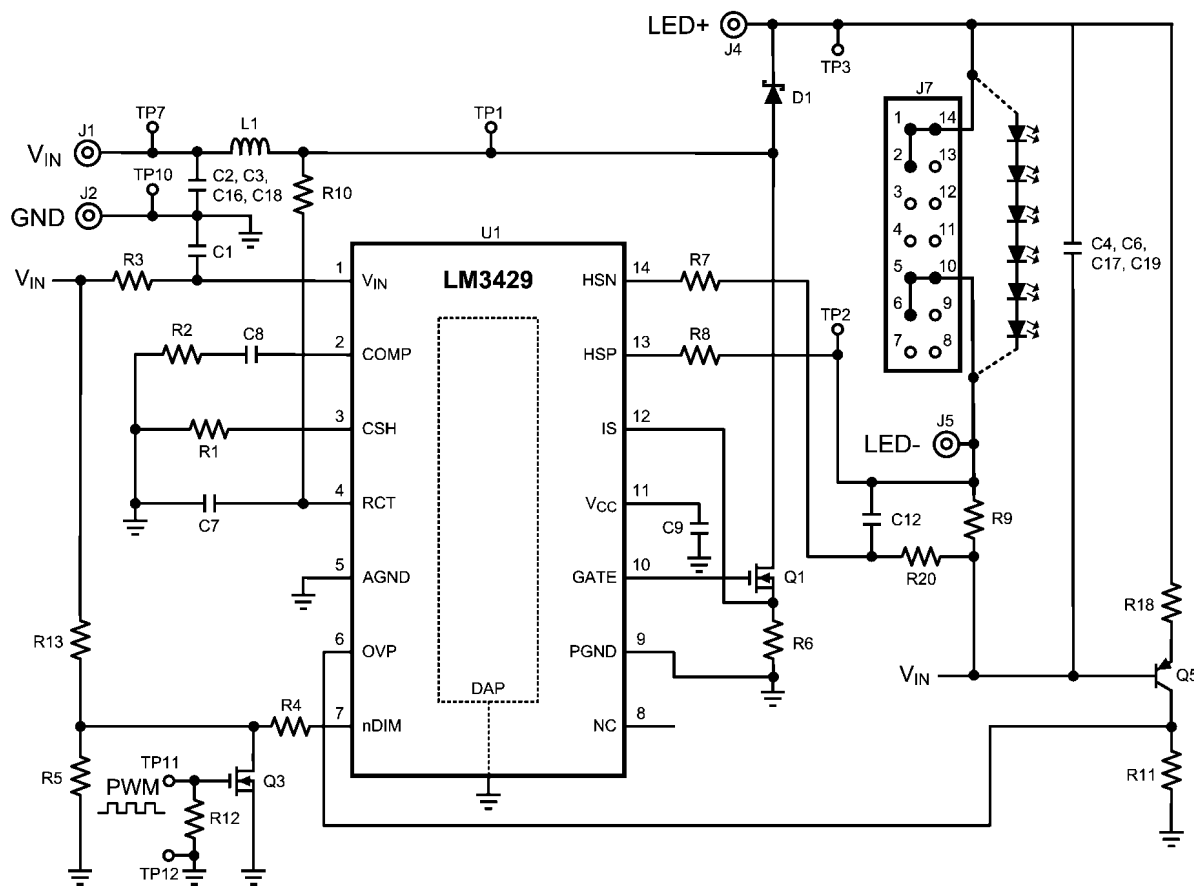

30100802

Pin Descriptions

Pin	Name	Description	Application Information
1	V_{IN}	Input Voltage	Bypass with 100 nF capacitor to AGND as close to the device as possible in the circuit board layout.
2	COMP	Compensation	Connect a capacitor to AGND.
3	CSH	Current Sense High	Connect a resistor to AGND to set the signal current. For analog dimming, connect a controlled current source or a potentiometer to AGND as detailed in the <i>Analog Dimming</i> section.
4	RCT	Resistor Capacitor Timing	Connect a resistor from the switch node and a capacitor to AGND to set the switching frequency.
5	AGND	Analog Ground	Connect to PGND through the DAP copper circuit board pad to provide proper ground return for CSH, COMP, and RCT.
6	OVP	Over-Voltage Protection	Connect to a resistor divider from V_O to program output over-voltage lockout (OVLO). Turn-off threshold is 1.24V and hysteresis for turn-on is provided by 20 μ A current source.
7	nDIM	Not DIM input	Connect a PWM signal for dimming as detailed in the <i>PWM Dimming</i> section and/or a resistor divider from V_{IN} to program input under-voltage lockout (UVLO). Turn-on threshold is 1.24V and hysteresis for turn-off is provided by 20 μ A current source.
8	NC	No Connection	Leave open.
9	PGND	Power Ground	Connect to AGND through the DAP copper circuit board pad to provide proper ground return for GATE.
10	GATE	Gate Drive Output	Connect to the gate of the external NFET.
11	V_{CC}	Internal Regulator Output	Bypass with a 2.2 μ F–3.3 μ F, ceramic capacitor to PGND.
12	IS	Main Switch Current Sense	Connect to the drain of the main N-channel MosFET switch for R_{DS-ON} sensing or to a sense resistor installed in the source of the same device.
13	HSP	High-Side LED Current Sense Positive	Connect through a series resistor to the positive side of the LED current sense resistor.
14	HSN	High-Side LED Current Sense Negative	Connect through a series resistor to the negative side of the LED current sense resistor.
DAP (15)	DAP	Thermal pad on bottom of IC	Star ground, connecting AGND and PGND.

Bill of Materials

Qty	Part ID	Part Value	Manufacturer	Part Number
2	C1, C4	0.1 μ F X7R 10% 100V	TDK	C2012X7R2A104K
4	C2, C3, C16, C18	4.7 μ F X7R 10% 100V	MURATA	GRM55ER72A475KA01L
3	C6, C17, C19	2.2 μ F X7R 10% 100V	TDK	C4532X7R2A225K
1	C7	1000 pF COG/NPO 5% 50V	MURATA	GRM2165C1H102JA01D
1	C8	1 μ F X7R 10% 16V	MURATA	GRM21BR71C105KA01L
1	C9	2.2 μ F X7R 10% 16V	MURATA	GRM21BR71C225KA12L
1	C12	0.1 μ F X7R 10% 25V	MURATA	GRM21BR71E104KA01L
1	D1	Schottky 100V 12A	VISHAY	12CWQ10FNPNBF
4	J1, J2, J4, J5	banana jack	KEYSTONE	575-8
1	J7	2 x 7 shrouded header	SAMTEC	TSSH-107-01-SDRA
1	L1	33 μ H 20% 6.3A	COILCRAFT	MSS1278-333MLB
1	Q1	NMOS 100V 40A	VISHAY	SUD40N10-25
1	Q3	NMOS 60V 260 mA	ON-SEMI	2N7002ET1G
1	Q5	PNP 150V 600 mA	FAIRCHILD	MMBT5401
1	R1	12.4 k Ω 1%	VISHAY	CRCW080512k4FKEA
1	R2	0 Ω 1%	VISHAY	CRCW08050000Z0EA
2	R3, R20	10 Ω 1%	VISHAY	CRCW080510R0FKEA
1	R4	16.9 k Ω 1%	VISHAY	CRCW080516k9FKEA
1	R5	1.43 k Ω 1%	VISHAY	CRCW08051k43FKEA
1	R6	0.05 Ω 1% 1W	VISHAY	WSL2512R0500FEA
2	R7, R8	1.0 k Ω 1%	VISHAY	CRCW08051k00FKEA
1	R9	0.1 Ω 1% 1W	VISHAY	WSL2512R1000FEA
1	R10	35.7 k Ω 1%	VISHAY	CRCW080535k7FKEA
1	R11	15.8 k Ω 1%	VISHAY	CRCW080515k8FKEA
2	R12, R13	10.0 k Ω 1%	VISHAY	CRCW080510k0FKEA
1	R18	750 k Ω 1%	VISHAY	CRCW0805750kFKEA
7	TP1, TP2, TP3, TP7, TP10, TP11, TP12	turret	KEYSTONE	1502-2
1	U1	Buck-boost controller	NSC	LM3429MH

PCB Layout

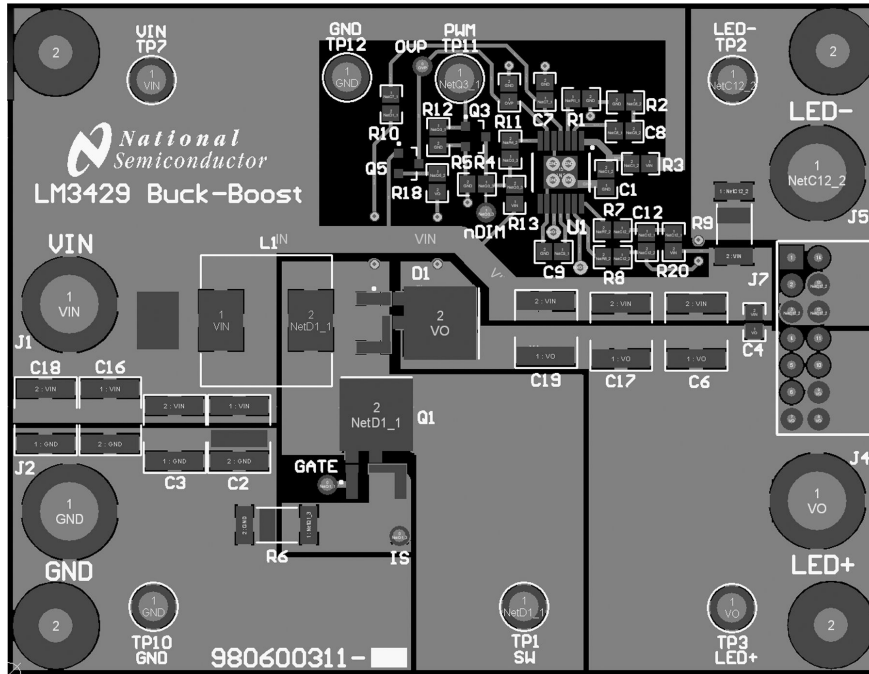

Top Layer

30100803

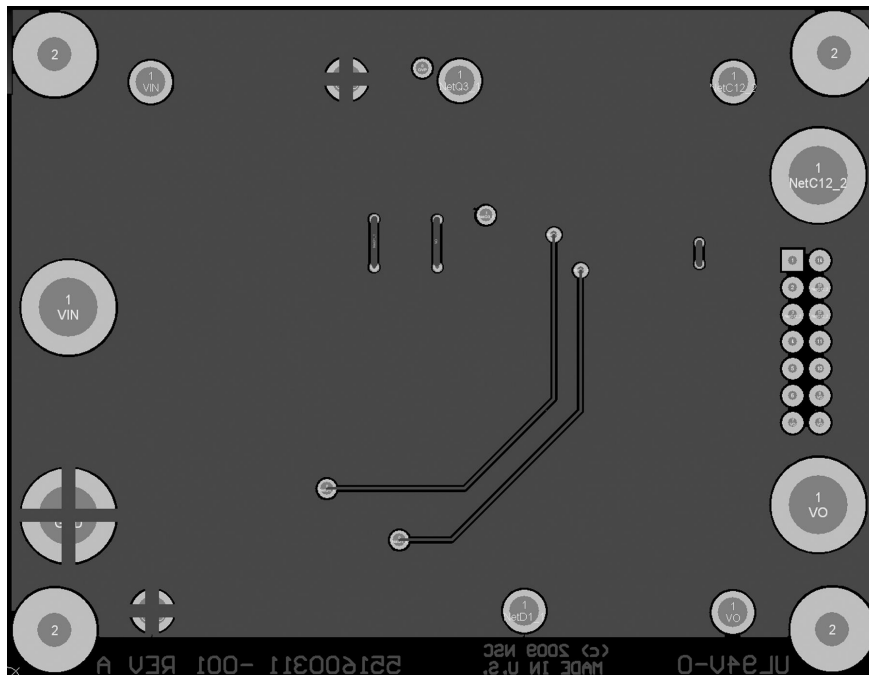

Bottom Layer

30100804

Design Procedure

Refer to LM3429 datasheet for design considerations.

SPECIFICATIONS

$N = 6$
 $V_{LED} = 3.5V$
 $r_{LED} = 325 \text{ m}\Omega$
 $V_{IN} = 24V$
 $V_{IN-MIN} = 10V; V_{IN-MAX} = 70V$
 $f_{SW} = 700 \text{ kHz}$
 $V_{SNS} = 100 \text{ mV}$
 $I_{LED} = 1A$
 $\Delta i_{L-PP} = 500 \text{ mA}$
 $\Delta i_{LED-PP} = 50 \text{ mA}$
 $\Delta V_{IN-PP} = 100 \text{ mV}$
 $I_{LIM} = 5A$
 $V_{TURN-ON} = 10V; V_{HYS} = 3V$
 $V_{TURN-OFF} = 60V; V_{HYSO} = 15V$

1. OPERATING POINT

Solve for V_O and r_D :

$$V_O = N \times V_{LED} = 6 \times 3.5V = 21V$$

$$r_D = N \times r_{LED} = 6 \times 325 \text{ m}\Omega = 1.95\Omega$$

Solve for D , D' , D_{MAX} , and D_{MIN} :

$$D = \frac{V_O}{V_O + V_{IN}} = \frac{21V}{21V + 24V} = 0.467$$

$$D' = 1 - D = 1 - 0.467 = 0.533$$

$$D_{MIN} = \frac{V_O}{V_O + V_{IN-MAX}} = \frac{21V}{21V + 70V} = 0.231$$

$$D_{MAX} = \frac{V_O}{V_O + V_{IN-MIN}} = \frac{21V}{21V + 10V} = 0.677$$

2. SWITCHING FREQUENCY

Assume $C7 = 1 \text{ nF}$ and solve for $R10$:

$$R10 = \frac{25}{f_{SW} \times C7} = \frac{25}{700 \text{ kHz} \times 1 \text{ nF}} = 35.7 \text{ k}\Omega$$

The closest standard resistor is actually $35.7 \text{ k}\Omega$ therefore the f_{SW} is:

$$f_{SW} = \frac{25}{R10 \times C7} = \frac{25}{35.7 \text{ k}\Omega \times 1 \text{ nF}} = 700 \text{ kHz}$$

The chosen components from step 2 are:

$C7 = 1 \text{ nF}$ $R10 = 35.7 \text{ k}\Omega$

3. AVERAGE LED CURRENT

Solve for $R9$:

$$R9 = \frac{V_{SNS}}{I_{LED}} = \frac{100 \text{ mV}}{1A} = 0.1\Omega$$

Assume $R1 = 12.4 \text{ k}\Omega$ and solve for $R8$:

$$R8 = \frac{I_{LED} \times R1 \times R9}{1.24V} = \frac{1A \times 12.4 \text{ k}\Omega \times 0.1\Omega}{1.24V} = 1.0 \text{ k}\Omega$$

The closest standard resistor for $R9$ is 0.1Ω and the closest for $R8$ (and $R7$) is actually $1 \text{ k}\Omega$ therefore I_{LED} is:

$$I_{LED} = \frac{1.24V \times R8}{R9 \times R1} = \frac{1.24V \times 1.0 \text{ k}\Omega}{0.1\Omega \times 12.4 \text{ k}\Omega} = 1.0A$$

The chosen components from step 3 are:

$R9 = 0.1\Omega$ $R1 = 12.4 \text{ k}\Omega$ $R8 = R7 = 1 \text{ k}\Omega$
--

4. INDUCTOR RIPPLE CURRENT

Solve for $L1$:

$$L1 = \frac{V_{IN} \times D}{\Delta i_{L-PP} \times f_{SW}} = \frac{24V \times 0.467}{500 \text{ mA} \times 700 \text{ kHz}} = 32 \mu\text{H}$$

The closest standard inductor is $33 \mu\text{H}$ therefore the actual Δi_{L-PP} is:

$$\Delta i_{L-PP} = \frac{V_{IN} \times D}{L1 \times f_{SW}} = \frac{24V \times 0.467}{33 \mu\text{H} \times 700 \text{ kHz}} = 485 \text{ mA}$$

Determine minimum allowable RMS current rating:

$$I_{L-RMS} = \frac{I_{LED}}{D'} \times \sqrt{1 + \frac{1}{12} \times \left(\frac{\Delta i_{L-PP} \times D'}{I_{LED}} \right)^2}$$

$$I_{L-RMS} = \frac{1A}{0.533} \times \sqrt{1 + \frac{1}{12} \times \left(\frac{485 \text{ mA} \times 0.533}{1A} \right)^2}$$

$$I_{L-RMS} = 1.88A$$

The chosen component from step 4 is:

$L1 = 33 \mu\text{H}$

5. OUTPUT CAPACITANCE

Solve for C_O :

$$C_O = \frac{I_{LED} \times D}{r_D \times \Delta i_{LED-PP} \times f_{SW}}$$

$$C_O = \frac{1A \times 0.467}{1.95\Omega \times 50 \text{ mA} \times 700 \text{ kHz}} = 6.84 \mu\text{F}$$

A total value of 6.6 μF (using 3 2.2 μF X7R ceramic capacitors) is chosen therefore the actual Δi_{LED-PP} is:

$$\Delta i_{LED-PP} = \frac{I_{LED} \times D}{r_D \times C_O \times f_{SW}}$$

$$\Delta i_{LED-PP} = \frac{1A \times 0.467}{1.95\Omega \times 6.6 \mu\text{F} \times 700 \text{ kHz}} = 52 \text{ mA}$$

Determine minimum allowable RMS current rating:

$$I_{CO-RMS} = I_{LED} \times \sqrt{\frac{D_{MAX}}{1 - D_{MAX}}} = 1A \times \sqrt{\frac{0.677}{1 - 0.677}} = 1.45A$$

The chosen components from step 5 are:

$$C6 = C17 = C19 = 2.2 \mu\text{F}$$

6. PEAK CURRENT LIMIT

Solve for $R6$:

$$R6 = \frac{245 \text{ mV}}{I_{LIM}} = \frac{245 \text{ mV}}{5A} = 0.049\Omega$$

The closest standard resistor is 0.05 Ω therefore I_{LIM} is:

$$I_{LIM} = \frac{245 \text{ mV}}{R6} = \frac{245 \text{ mV}}{0.05\Omega} = 4.9A$$

The chosen component from step 6 is:

$$R6 = 0.05\Omega$$

7. LOOP COMPENSATION

ω_{P1} is approximated:

$$\omega_{P1} = \frac{1 + D}{r_D \times C_O} = \frac{1.467}{1.95\Omega \times 6.8 \mu\text{F}} = 110k \frac{\text{rad}}{\text{sec}}$$

ω_{Z1} is approximated:

$$\omega_{Z1} = \frac{r_D \times D^2}{D \times L1} = \frac{1.95\Omega \times 0.533^2}{0.467 \times 33 \mu\text{H}} = 36k \frac{\text{rad}}{\text{sec}}$$

T_{U0} is approximated:

$$T_{U0} = \frac{D' \times 620V}{(1 + D) \times I_{LED} \times R6} = \frac{0.533 \times 620V}{1.467 \times 1A \times 0.05\Omega} = 4510$$

To ensure stability, calculate ω_{P2} :

$$\omega_{P2} = \frac{\min(\omega_{P1}, \omega_{Z1})}{5 \times T_{U0}} = \frac{\omega_{Z1}}{5 \times 4510} = \frac{36k \frac{\text{rad}}{\text{sec}}}{5 \times 4510} = 1.596 \frac{\text{rad}}{\text{sec}}$$

Solve for $C8$:

$$C8 = \frac{1}{\omega_{P2} \times 5e^6\Omega} = \frac{1}{1.596 \frac{\text{rad}}{\text{sec}} \times 5e^6\Omega} = 0.13 \mu\text{F}$$

Since PWM dimming can be evaluated with this board, a much larger compensation capacitor $C8 = 1.0 \mu\text{F}$ is chosen.

To attenuate switching noise, calculate ω_{P3} :

$$\omega_{P3} = \max(\omega_{P1}, \omega_{Z1}) \times 10 = \omega_{P1} \times 10$$

$$\omega_{P3} = 110k \frac{\text{rad}}{\text{sec}} \times 10 = 1.1M \frac{\text{rad}}{\text{sec}}$$

Assume $R20 = 10\Omega$ and solve for $C12$:

$$C12 = \frac{1}{10\Omega \times \omega_{P3}} = \frac{1}{10\Omega \times 1.1M \frac{\text{rad}}{\text{sec}}} = 0.091 \mu\text{F}$$

The chosen components from step 7 are:

$$C8 = 1.0 \mu\text{F}$$

$$R20 = 10\Omega$$

$$C12 = 0.1 \mu\text{F}$$

8. INPUT CAPACITANCE

Solve for the minimum C_{IN} :

$$C_{IN} = \frac{I_{LED} \times D}{\Delta V_{IN-PP} \times f_{SW}} = \frac{1A \times 0.467}{100 \text{ mV} \times 700 \text{ kHz}} = 6.66 \mu\text{F}$$

To minimize power supply interaction a 3x larger capacitance of approximately 20 μF is used, therefore the actual ΔV_{IN-PP} is much lower. Since high voltage ceramic capacitor selection is limited, four 4.7 μF X7R capacitors are chosen.

Determine minimum allowable RMS current rating:

$$I_{IN-RMS} = I_{LED} \times \sqrt{\frac{D_{MAX}}{1 - D_{MAX}}} = 1A \times \sqrt{\frac{0.677}{1 - 0.677}} = 1.45A$$

The chosen components from step 8 are:

$$C2 = C3 = C16 = C18 = 4.7 \mu\text{F}$$

9. NFET

Determine minimum Q1 voltage rating and current rating:

$$V_{T-MAX} = V_{IN-MAX} + V_O = 70V + 21V = 91V$$

$$I_{T-RMS} = \frac{0.677}{1 - 0.677} \times 1A = 2.1A$$

A 100V NFET is chosen with a current rating of 40A due to the low $R_{DS-ON} = 50 \text{ m}\Omega$. Determine I_{T-RMS} and P_T :

$$I_{T-RMS} = \frac{I_{LED}}{D'} \times \sqrt{D} = \frac{1A}{0.533} \times \sqrt{0.467} = 1.28A$$

$$P_T = I_{T-RMS}^2 \times R_{DS-ON} = 1.28A^2 \times 50 \text{ m}\Omega = 82 \text{ mW}$$

The chosen component from step 9 is:

$$Q1 \rightarrow 40A, 100V, \text{ DPAK}$$

10. DIODE

Determine minimum D1 voltage rating and current rating:

$$V_{RD-MAX} = V_{IN-MAX} + V_O = 70V + 21V = 91V$$

$$I_{D-MAX} = I_{LED} = 1A$$

A 100V diode is chosen with a current rating of 12A and $V_D = 600 \text{ mV}$. Determine P_D :

$$P_D = I_D \times V_{FD} = 1A \times 600 \text{ mV} = 600 \text{ mW}$$

The chosen component from step 10 is:

$$D1 \rightarrow 12A, 100V, \text{ DPAK}$$

11. INPUT UVLO

Since PWM dimming will be evaluated, a three resistor network will be used. Assume $R13 = 10 \text{ k}\Omega$ and solve for $R5$:

$$R5 = \frac{1.24V \times R13}{V_{TURN-ON} - 1.24V} = \frac{1.24V \times 10 \text{ k}\Omega}{10V - 1.24V} = 1.42 \text{ k}\Omega$$

The closest standard resistor is $1.43 \text{ k}\Omega$ therefore $V_{TURN-ON}$ is:

$$V_{TURN-ON} = \frac{1.24V \times (R5 + R13)}{R5}$$

$$V_{TURN-ON} = \frac{1.24V \times (1.43 \text{ k}\Omega + 10 \text{ k}\Omega)}{1.43 \text{ k}\Omega} = 9.91V$$

Solve for $R4$:

$$R4 = \frac{R5 \times (V_{HYS} - 20 \mu A \times R13)}{20 \mu A \times (R5 + R13)}$$

$$R4 = \frac{1.43 \text{ k}\Omega \times (2.9V - 20 \mu A \times 10 \text{ k}\Omega)}{20 \mu A \times (1.43 \text{ k}\Omega + 10 \text{ k}\Omega)} = 16.9 \text{ k}\Omega$$

The closest standard resistor is $16.9 \text{ k}\Omega$ making V_{HYS} :

$$V_{HYS} = \frac{20 \mu A \times R4 \times (R5 + R13)}{R5} + 20 \mu A \times R_{UV2}$$

$$V_{HYS} = \frac{20 \mu A \times 16.9 \text{ k}\Omega \times (1.43 \text{ k}\Omega + 10 \text{ k}\Omega)}{1.43 \text{ k}\Omega} + 20 \mu A \times 10 \text{ k}\Omega = 2.9V$$

The chosen components from step 11 are:

$$\begin{aligned} R5 &= 1.43 \text{ k}\Omega \\ R13 &= 10 \text{ k}\Omega \\ R4 &= 16.9 \text{ k}\Omega \end{aligned}$$

12. OUTPUT OVLO

Solve for $R18$:

$$R18 = \frac{V_{HYSO}}{20 \mu A} = \frac{15V}{20 \mu A} = 750 \text{ k}\Omega$$

The closest standard resistor is $750 \text{ k}\Omega$ therefore V_{HYSO} is:

$$V_{HYSO} = R18 \times 20 \mu A = 750 \text{ k}\Omega \times 20 \mu A = 15V$$

Solve for $R11$:

$$R11 = \frac{1.24V \times R18}{V_{TURN-OFF} - 1.24V} = \frac{1.24V \times 750 \text{ k}\Omega}{60V - 1.24V} = 15.8 \text{ k}\Omega$$

The closest standard resistor is $15.8 \text{ k}\Omega$ making $V_{TURN-OFF}$:

$$V_{TURN-OFF} = \frac{1.24V \times (R11 + R18)}{R11}$$

$$V_{TURN-OFF} = \frac{1.24V \times (15.8 \text{ k}\Omega + 750 \text{ k}\Omega)}{15.8 \text{ k}\Omega} = 60V$$

The chosen components from step 12 are:

$$\begin{aligned} R11 &= 15.8 \text{ k}\Omega \\ R18 &= 750 \text{ k}\Omega \end{aligned}$$

Typical Waveforms

$T_A = +25^\circ\text{C}$, $V_{IN} = 24\text{V}$ and $V_O = 21\text{V}$.

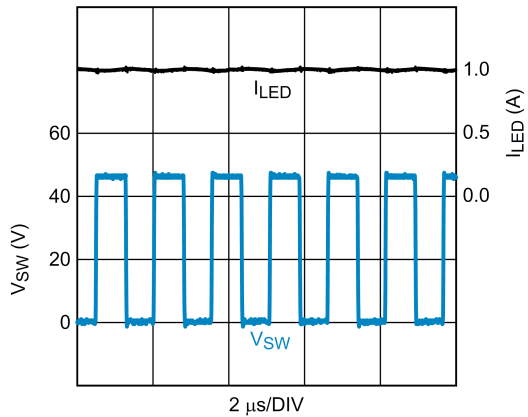

STANDARD OPERATION
TP1 switch node voltage (V_{SW})
LED current (I_{LED})

30100859

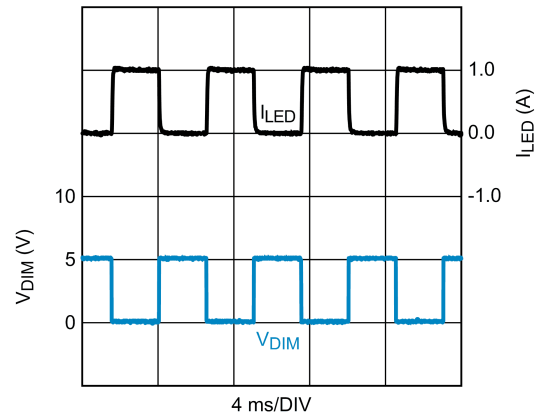

200Hz 50% PWM DIMMING
TP11 dim voltage (V_{DIM})
LED current (I_{LED})

30100860

Alternate Designs

Alternate designs with the LM3429 evaluation board are possible with very few changes to the existing hardware. The evaluation board FETs and diodes are already rated higher than necessary for design flexibility. The input UVLO, output OVP, input and output capacitance can remain the same for

the designs shown below. These alternate designs can be evaluated by changing only R9, R10, and L1.

The table below gives the main specifications for four different designs and the corresponding values for R9, R10, and L1. PWM dimming can be evaluated with any of these designs.

Specification / Component	Design 1	Design 2	Design 3	Design 4
V_{IN}	10V - 45V	15V - 50V	20V - 55V	25V - 60V
V_O	14V	21V	28V	35V
f_{SW}	600kHz	700kHz	500kHz	700kHz
I_{LED}	2A	500mA	2.5A	1.25A
R9	0.05 Ω	0.2 Ω	0.04 Ω	0.08 Ω
R10	41.2 k Ω	35.7 k Ω	49.9 k Ω	35.7 k Ω
L1	22 μH	68 μH	15 μH	33 μH

Notes

For more National Semiconductor product information and proven design tools, visit the following Web sites at:

Products		Design Support	
Amplifiers	www.national.com/amplifiers	WEBENCH® Tools	www.national.com/webench
Audio	www.national.com/audio	App Notes	www.national.com/appnotes
Clock and Timing	www.national.com/timing	Reference Designs	www.national.com/refdesigns
Data Converters	www.national.com/adc	Samples	www.national.com/samples
Interface	www.national.com/interface	Eval Boards	www.national.com/evalboards
LVDS	www.national.com/lvds	Packaging	www.national.com/packaging
Power Management	www.national.com/power	Green Compliance	www.national.com/quality/green
Switching Regulators	www.national.com/switchers	Distributors	www.national.com/contacts
LDOs	www.national.com/lido	Quality and Reliability	www.national.com/quality
LED Lighting	www.national.com/led	Feedback/Support	www.national.com/feedback
Voltage Reference	www.national.com/vref	Design Made Easy	www.national.com/easy
PowerWise® Solutions	www.national.com/powerwise	Solutions	www.national.com/solutions
Serial Digital Interface (SDI)	www.national.com/sdi	Mil/Aero	www.national.com/milaero
Temperature Sensors	www.national.com/tempensors	SolarMagic™	www.national.com/solarmagic
Wireless (PLL/VCO)	www.national.com/wireless	PowerWise® Design University	www.national.com/training

THE CONTENTS OF THIS DOCUMENT ARE PROVIDED IN CONNECTION WITH NATIONAL SEMICONDUCTOR CORPORATION ("NATIONAL") PRODUCTS. NATIONAL MAKES NO REPRESENTATIONS OR WARRANTIES WITH RESPECT TO THE ACCURACY OR COMPLETENESS OF THE CONTENTS OF THIS PUBLICATION AND RESERVES THE RIGHT TO MAKE CHANGES TO SPECIFICATIONS AND PRODUCT DESCRIPTIONS AT ANY TIME WITHOUT NOTICE. NO LICENSE, WHETHER EXPRESS, IMPLIED, ARISING BY ESTOPPEL OR OTHERWISE, TO ANY INTELLECTUAL PROPERTY RIGHTS IS GRANTED BY THIS DOCUMENT.

TESTING AND OTHER QUALITY CONTROLS ARE USED TO THE EXTENT NATIONAL DEEMS NECESSARY TO SUPPORT NATIONAL'S PRODUCT WARRANTY. EXCEPT WHERE MANDATED BY GOVERNMENT REQUIREMENTS, TESTING OF ALL PARAMETERS OF EACH PRODUCT IS NOT NECESSARILY PERFORMED. NATIONAL ASSUMES NO LIABILITY FOR APPLICATIONS ASSISTANCE OR BUYER PRODUCT DESIGN. BUYERS ARE RESPONSIBLE FOR THEIR PRODUCTS AND APPLICATIONS USING NATIONAL COMPONENTS. PRIOR TO USING OR DISTRIBUTING ANY PRODUCTS THAT INCLUDE NATIONAL COMPONENTS, BUYERS SHOULD PROVIDE ADEQUATE DESIGN, TESTING AND OPERATING SAFEGUARDS.

EXCEPT AS PROVIDED IN NATIONAL'S TERMS AND CONDITIONS OF SALE FOR SUCH PRODUCTS, NATIONAL ASSUMES NO LIABILITY WHATSOEVER, AND NATIONAL DISCLAIMS ANY EXPRESS OR IMPLIED WARRANTY RELATING TO THE SALE AND/OR USE OF NATIONAL PRODUCTS INCLUDING LIABILITY OR WARRANTIES RELATING TO FITNESS FOR A PARTICULAR PURPOSE, MERCHANTABILITY, OR INFRINGEMENT OF ANY PATENT, COPYRIGHT OR OTHER INTELLECTUAL PROPERTY RIGHT.

LIFE SUPPORT POLICY

NATIONAL'S PRODUCTS ARE NOT AUTHORIZED FOR USE AS CRITICAL COMPONENTS IN LIFE SUPPORT DEVICES OR SYSTEMS WITHOUT THE EXPRESS PRIOR WRITTEN APPROVAL OF THE CHIEF EXECUTIVE OFFICER AND GENERAL COUNSEL OF NATIONAL SEMICONDUCTOR CORPORATION. As used herein:

Life support devices or systems are devices which (a) are intended for surgical implant into the body, or (b) support or sustain life and whose failure to perform when properly used in accordance with instructions for use provided in the labeling can be reasonably expected to result in a significant injury to the user. A critical component is any component in a life support device or system whose failure to perform can be reasonably expected to cause the failure of the life support device or system or to affect its safety or effectiveness.

National Semiconductor and the National Semiconductor logo are registered trademarks of National Semiconductor Corporation. All other brand or product names may be trademarks or registered trademarks of their respective holders.

Copyright© 2009 National Semiconductor Corporation

For the most current product information visit us at www.national.com



National Semiconductor Americas Technical Support Center
Email: support@nsc.com
Tel: 1-800-272-9959

National Semiconductor Europe Technical Support Center
Email: europe.support@nsc.com

National Semiconductor Asia Pacific Technical Support Center
Email: ap.support@nsc.com

National Semiconductor Japan Technical Support Center
Email: jpn.feedback@nsc.com