

LM3431 Evaluation Board

National Semiconductor
Application Note 1764
Allan Fisher
January 10, 2008



Introduction

The LM3431 is a combination switching boost voltage regulator and multi-channel LED current controller. The LM3431 Evaluation Board is designed to drive 4 parallel strings of 8 series LEDs at 140mA per string from an input voltage range of 8V to 18V. The boost switcher regulates LED cathode voltage for optimum efficiency, while allowing the output voltage to vary according to the LED forward voltage. The LM3431 incorporates complete fault protection features including LED short and open protection, over-current protection, over-voltage and under-voltage protection, and thermal shutdown. The error detection flag can be monitored at the DLY post, which has a programmable delay time.

The board includes a DIM input terminal for a selectable digital or analog dimming control signal. PWM dimming frequencies up to 1kHz at 100:1 contrast ratio and contrast ratios up to 500:1 at 200Hz are possible.

The evaluation board is designed to operate at ambient temperatures up to 70°C.

The complete evaluation board schematic is shown in Figure 2. Typical waveforms and performance curves are shown in Figures 3-8.

Although a wide variety of LED combinations and currents can be driven with the LM3431, the schematic must be modified to achieve optimum performance with any given array. However, for initial evaluation and demonstration, some modifications from the default settings are possible. A few of the possible variations are described below and listed in Tables 2 and 3.

LED current can be set as low as 100mA per string without significantly degrading performance; the number of strings can be reduced from 4 to 3 or 2; and the number of series LEDs can be set between 6 and 9.

To design for LED arrays other than the default, and for complete device and design information, refer to the LM3431 datasheet.

Before Powering Up

Before powering up the LM3431 evaluation board, a few options must be selected.

First, verify that the default LED current setting of 140mA is appropriate to drive the LEDs. To drive LEDs at other currents, refer to Table 2. If the required LED current is not listed, refer to the LM3431 datasheet, as more extensive modifications will be required.

By default, the LM3431 evaluation board has channels 1-4 enabled. To drive fewer channels, first remove the sense resistor or NPN on the channel to be disabled (R10-R13 or Q2-Q5). Then refer to Table 3 and make any other required changes. Table 3 also gives options for driving fewer LEDs per string.

Finally, select the type of dimming control signal to be used. By default, R-MODE is installed, which enables digital dimming control mode. To use this mode, connect a digital PWM signal to the DIM post. The dimming signal must have a minimum high logic level of 2.3V.

To enable analog dimming, remove the MODE resistor and connect an analog voltage level to the DIM post. In analog mode, the dimming duty cycle is varied by the voltage at the DIM post within a range of 0.37V to 2.5V. The default analog dimming frequency is 1kHz. To modify this frequency, change C5 as described in the datasheet.

Any dimming frequency between 180Hz and 20kHz can be used in either digital or analog dimming control mode. However the default schematic is not designed for dimming frequencies above 1kHz. Once the evaluation board has been configured, connect the LED strings as shown in Figure 2. The first anode of each string connects to the VA post and the last cathode of each string connects to VC1 through VC4. LEDs can be connected either via the 8-pin header or to the terminal posts. Figure 1 shows the pinout of the header.

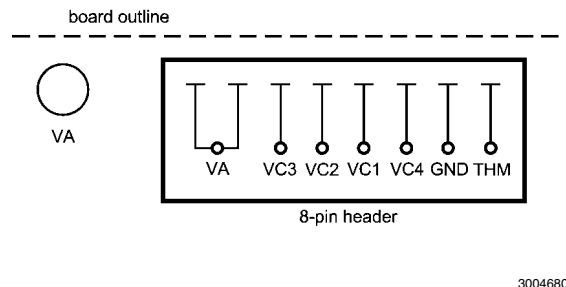

30046801

FIGURE 1. LED Connection, Top View Header Pinout

Connect the input voltage supply to the VIN and GND posts. When all connections and polarities have been verified, power can be applied. When the input voltage rises above 7.7V typically, the EN pin will cross the UVLO threshold and the LM3431 will startup. EN can be pulled low (via the EN post) to shutdown the evaluation board.

8V to 18V input
 700 kHz switching, 180 Hz – 1 kHz dimming
 4 strings of 8 LEDs, 140 mA per string

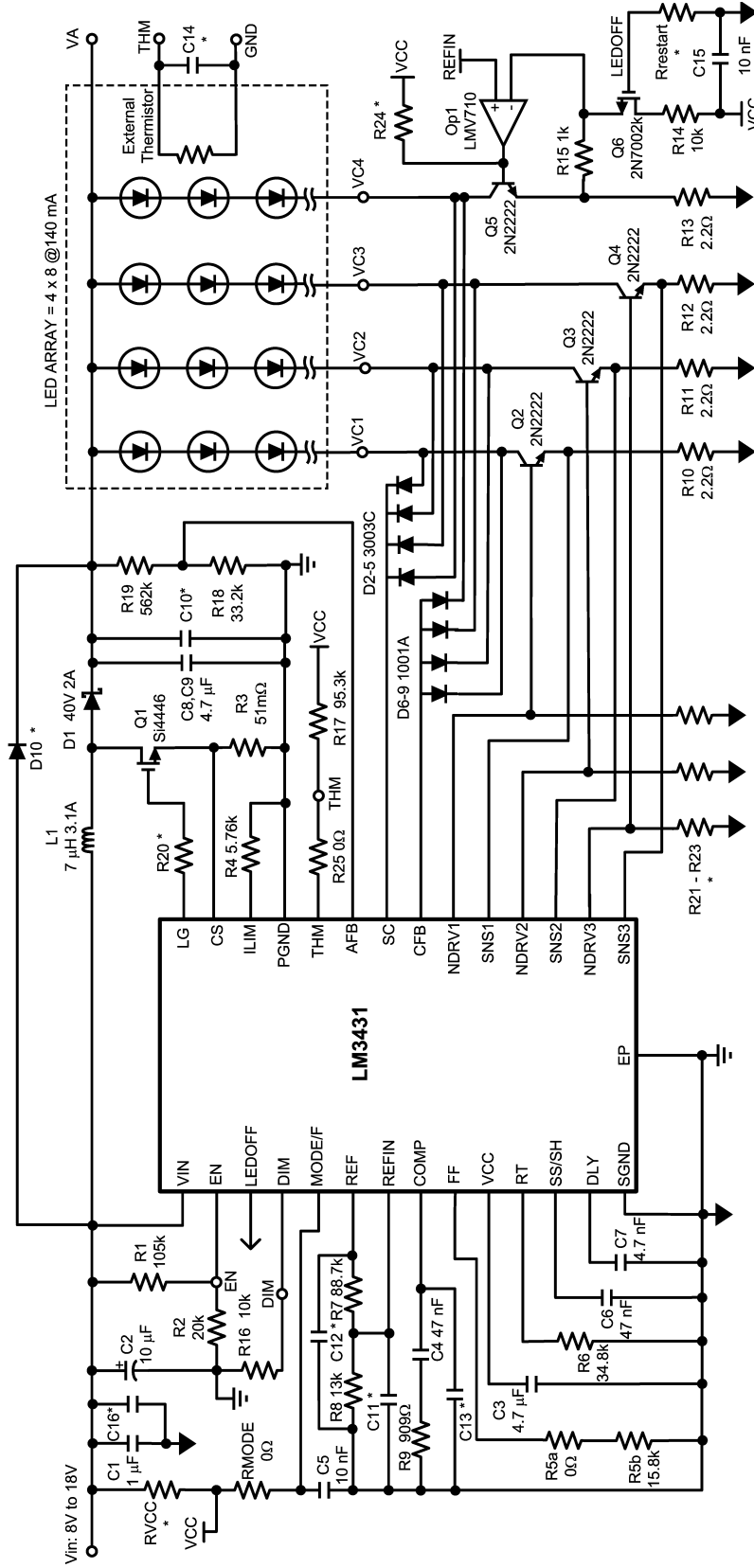

* = not installed

30046802

FIGURE 2. Complete LM3431 Eval Board Schematic

TABLE 1. Standard Bill of Materials

Ref #	Function	Description	Part Number	Manufacturer
IC1		Boost controller and LED driver	LM3431MHX	National Semiconductor
C1	Cin	1 μ F 50V B ceramic	GRM32RB11H105KA01	Murata
C2	Cin	10 μ F 50V electrolytic	UUD1H100MCL	Nichicon
C3	VCC	4.7 μ F 10V X7R ceramic	C2012X7R1A475M	TDK
C4	Comp	47nF 50V X7R ceramic	GRM21BR71H473KA01L3K	Murata
C5	MODE/F	10nF 10V COG ceramic	GRM2195C1H103JA01D	Murata
C6	SS	47nF 50V X7R ceramic	GRM21BR71H473KA01L3K	Murata
C7	DLY	4.7nF 50V COG ceramic	GRM2165C1H472JA01D	Murata
C8	VA	4.7 μ F 50V X7R ceramic	GRM32ER71H475KA88L	Murata
C9	VA	4.7 μ F 50V X7R ceramic	GRM32ER71H475KA88L	Murata
C10	VA	not installed	-	-
C11	REFIN bypass	not installed	-	-
C12	REF bypass	not installed	-	-
C13	Comp2	not installed	-	-
C14	THM	not installed	-	-
C15	OP1	10nF 10V COG ceramic	GRM2195C1H103JA01D	Murata
C16	Cin	not installed	-	-
D1	power diode	2A 40V Schottky diode	SS24	Vishay
D2-D3	SC	600mA dual cathode diode	CMPD3003C	Central Semiconductor
D4-D5	SC	600mA dual cathode diode	CMPD3003C	Central Semiconductor
D6-D7	CFB	250mA dual anode diode	CMPD1001A	Central Semiconductor
D8-D9	CFB	250mA dual anode diode	CMPD1001A	Central Semiconductor
D10	bypass diode	not installed	-	-
L1	power coil	7 μ H 3.1A inductor	MSS1038-702NL	Coilcraft
Op1	ch.4	rail to rail op amp	LMV710	National Semiconductor
Q1	Power FET	4A 40V N-channel MOSFET	Si4446DY	Vishay
Q2-Q5	regulator	40V 600mA NPN transistor	CXT2222A	Central Semiconductor
Q6	ch.4	60V 200mA N-channel MOSFET	2N7002K	Vishay
R1	EN uvlo set	105k 1%		
R2	EN uvlo set	20k		
R3	I sense	51mohm 0.5W 1%	WSL2010R0510F	Vishay
R4	I limit	5.76k 1%		
R5a	FF	0 Ω		
R5b	FF	15.8k 1%		
R6	RT	34.8k		
R7	REFIN set	88.7k 1%		
R8	REFIN set	13.0k 1%		
R9	Comp	909 Ω 1%		
R10 - R13	LED sense	2.2 Ω 1%		
R14	ch.4	10k		
R15	ch.4	1k		
R16	DIM	10k		
R17	THM	95.3k		

Ref #	Function	Description	Part Number	Manufacturer
R18	AFB	33.2k		
R19	AFB	562k		
R20	HG	not installed	-	-
R21 - R23	NDRV	not installed	-	-
R24	ch.4	not installed	-	-
R25	THM hys	0Ω		
Rmode	MODE/F	0Ω		
Rrestart	restart select	not installed	-	-
RVCC		not installed	-	-

Optional Components

Several of the components shown in the schematic are not installed and are optional. These components are typically not required, but may be useful in some applications. C10 is provided for adding additional output capacitance or for using more capacitors with smaller case sizes. C11 and C12 can be used to filter reference voltage noise. Noise at the REF_IN pin can appear as noise in the LED current. Whether these capacitors are required depends on the amount of switching noise, type of NPN used, and how much noise is tolerable in the LED current. C13 is a second compensation capacitor, which may be required if a high ESR output capacitor is used. Refer to the datasheet for details. D10 provides a current path from VIN to VA during startup. By bypassing the inductor, D10 prevents VA from rising above VIN at the initial power-on. In some conditions an OVP fault may occur at startup without D10 installed. R20 is a gate drive resistor for the NFET, Q1. An R20 value of up to 10Ω can be used to reduce the rise and fall time of the gate drive to reduce switching noise. To install R20, first cut the trace between the R20 pads. R21-R23 are NDRV pull-down resistors. A value of 300Ω to 1k can reduce LED current noise. These resistors are typically most effective when driving NFET current regulators. RVCC connects VCC to VIN. For 5V input applications, a 4.7Ω resistor should be installed here to pull-up VCC. For these applications, additional input capacitance at C16 may also be required. R-restart enables the automatic restart function. Auto-restart cannot be enabled when four LED channels are used. If 3 or fewer channels are being driven, install R-restart with 0Ω to enable the auto-restart function, which restarts the LM3431 after a fault shutdown. R-MODE selects the DIM control mode as was described previously. For lower current applications, there is a second Q1 pad which fits SOT-23 size NFETs. An external NTC thermistor can be connected either between the THM pad and SGND terminal post or via pins 7 and 8 on the 8-pin header. This thermistor is used to monitor LED temperature. With the installed R17 value, the LM3431 will enter standby when the thermistor resistance falls to 31kΩ. For example, a thermistor with a 25°C resistance of 680k and a beta constant of 4125 will yield a shutdown temperature of 110°C. R25 is a hysteresis resistor for the THM function. The default value is 0Ω which results in a restart hysteresis of 10°C. Use R25 to increase the THM hysteresis according to the datasheet description. C14 can be installed as a noise filter for the external thermistor voltage.

LED String Options

Tables 2 and 3 give the required component changes for driving LED arrays other than the default. The values shown assume a typical LED Vf of 3.2V at 140mA. These tables are designed for simplicity and ease of modification, not optimum performance. Therefore, any of the changes listed below will result in a lower maximum contrast ratio as compared to the default LED array. For optimum performance, all component values should be reviewed. R5 in the tables refers to the sum of R5a and R5b shown on the schematic. For the best performance, R5 can be manually adjusted for the specific input voltage, dimming frequency, and LED current of each application.

TABLE 2. LED Current Settings (nc = no change)

LED current	R7	R8	R5
160mA	78.7k	13k	nc
130mA	100k	13k	17.4k
115mA	115k	13k	18.7k
100mA	93.1k	9.09k	20k

TABLE 3. LED Array Options at 140mA Setting (nc = no change)

2 Strings				
# of LEDs	R19	R3	R5	R6
6	432k	80m	24.9k	43.2k
7	499k	90m	28.7k	26.7k
8	nc	70m	30.1k	23.2k
3 Strings				
6	432k	nc	28k	43.2k
7	499k	nc	24.3k	nc
8	nc	nc	20k	nc
9	634k	nc	19.1k	30.1k
4 Strings				
6	432k	nc	19.1k	43.2k
7	499k	nc	16.9k	nc
9	634k	40m	14.3k	nc

Typical Evaluation Board Performance

Unless otherwise specified, the following conditions apply: $V_{in} = 12V$, $T_a = 25^{\circ}C$, LED array = 4 parallel strings of 8 LEDs at 140mA per string. LED part number: Nichia NFSW036BT.

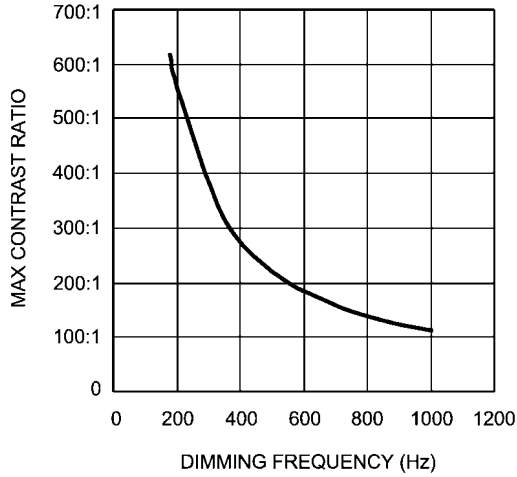

30046803

FIGURE 3. Maximum Contrast Ratio vs. Dimming Frequency

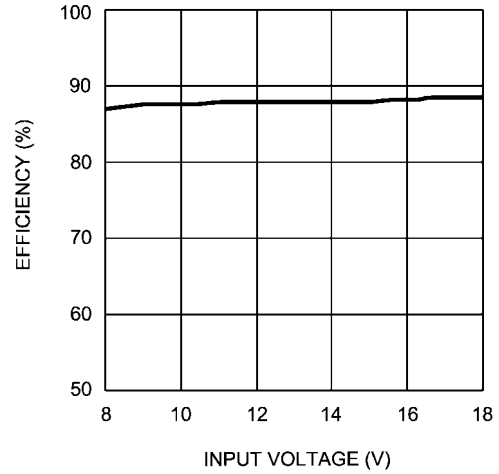

30046806

FIGURE 6. Efficiency vs. Input Voltage

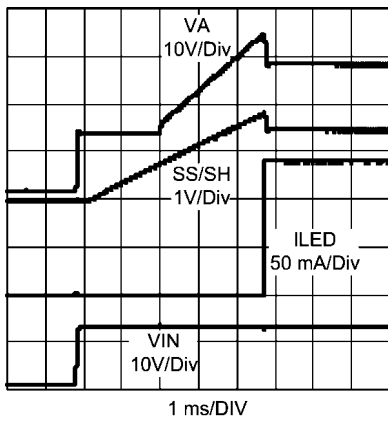

30046804

FIGURE 4. Power-On Startup Waveforms

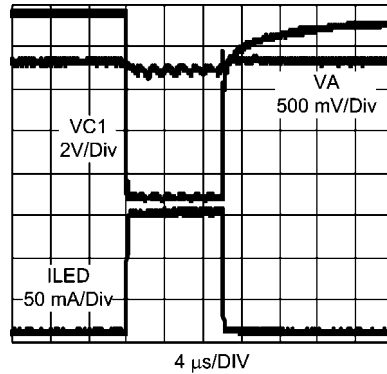

30046807

FIGURE 7. Typical Dimming Waveforms (1kHz at 1% duty)

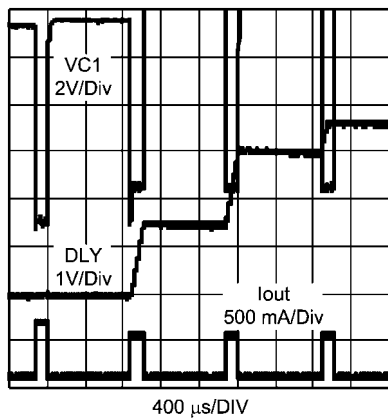

30046805

FIGURE 5. Fault Delay Waveforms (one LED open)

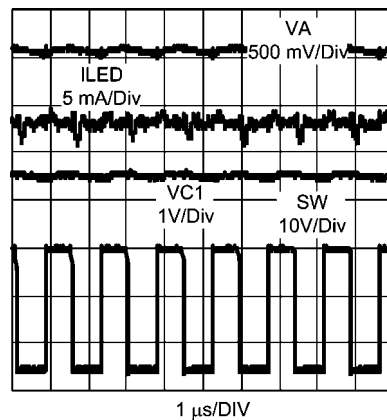

30046808

FIGURE 8. Boost Switching Waveforms

PCB Layout

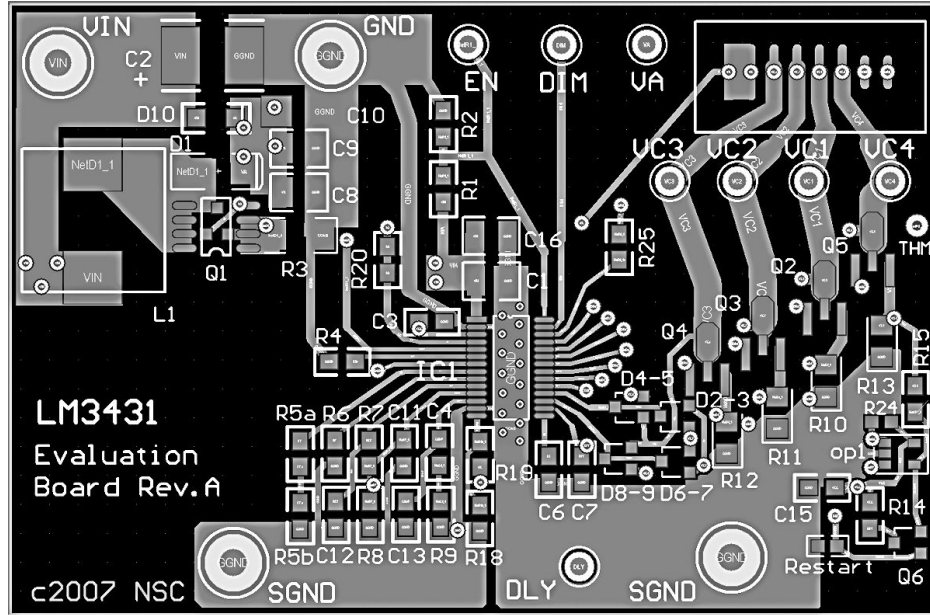

30046809

FIGURE 9. Top Side PCB Layout

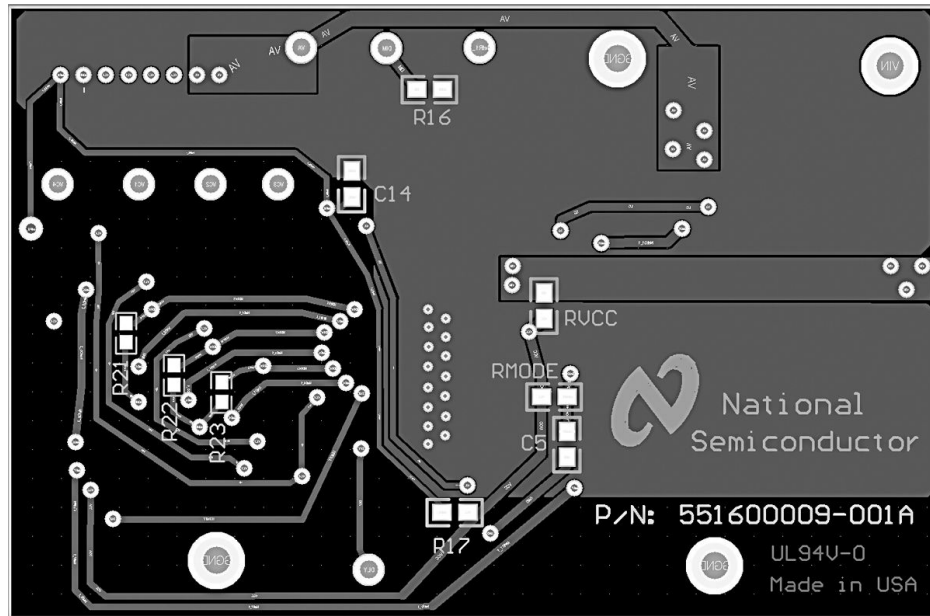

30046810

FIGURE 10. Bottom Side PCB Layout

Notes

AN-1764

Notes

For more National Semiconductor product information and proven design tools, visit the following Web sites at:

Products		Design Support	
Amplifiers	www.national.com/amplifiers	WEBENCH	www.national.com/webench
Audio	www.national.com/audio	Analog University	www.national.com/AU
Clock Conditioners	www.national.com/timing	App Notes	www.national.com/appnotes
Data Converters	www.national.com/adc	Distributors	www.national.com/contacts
Displays	www.national.com/displays	Green Compliance	www.national.com/quality/green
Ethernet	www.national.com/ethernet	Packaging	www.national.com/packaging
Interface	www.national.com/interface	Quality and Reliability	www.national.com/quality
LVDS	www.national.com/lvds	Reference Designs	www.national.com/refdesigns
Power Management	www.national.com/power	Feedback	www.national.com/feedback
Switching Regulators	www.national.com/switchers		
LDOs	www.national.com/ldo		
LED Lighting	www.national.com/led		
PowerWise	www.national.com/powerwise		
Serial Digital Interface (SDI)	www.national.com/sdi		
Temperature Sensors	www.national.com/tempsensors		
Wireless (PLL/VCO)	www.national.com/wireless		

THE CONTENTS OF THIS DOCUMENT ARE PROVIDED IN CONNECTION WITH NATIONAL SEMICONDUCTOR CORPORATION ("NATIONAL") PRODUCTS. NATIONAL MAKES NO REPRESENTATIONS OR WARRANTIES WITH RESPECT TO THE ACCURACY OR COMPLETENESS OF THE CONTENTS OF THIS PUBLICATION AND RESERVES THE RIGHT TO MAKE CHANGES TO SPECIFICATIONS AND PRODUCT DESCRIPTIONS AT ANY TIME WITHOUT NOTICE. NO LICENSE, WHETHER EXPRESS, IMPLIED, ARISING BY ESTOPPEL OR OTHERWISE, TO ANY INTELLECTUAL PROPERTY RIGHTS IS GRANTED BY THIS DOCUMENT.

TESTING AND OTHER QUALITY CONTROLS ARE USED TO THE EXTENT NATIONAL DEEMS NECESSARY TO SUPPORT NATIONAL'S PRODUCT WARRANTY. EXCEPT WHERE MANDATED BY GOVERNMENT REQUIREMENTS, TESTING OF ALL PARAMETERS OF EACH PRODUCT IS NOT NECESSARILY PERFORMED. NATIONAL ASSUMES NO LIABILITY FOR APPLICATIONS ASSISTANCE OR BUYER PRODUCT DESIGN. BUYERS ARE RESPONSIBLE FOR THEIR PRODUCTS AND APPLICATIONS USING NATIONAL COMPONENTS. PRIOR TO USING OR DISTRIBUTING ANY PRODUCTS THAT INCLUDE NATIONAL COMPONENTS, BUYERS SHOULD PROVIDE ADEQUATE DESIGN, TESTING AND OPERATING SAFEGUARDS.

EXCEPT AS PROVIDED IN NATIONAL'S TERMS AND CONDITIONS OF SALE FOR SUCH PRODUCTS, NATIONAL ASSUMES NO LIABILITY WHATSOEVER, AND NATIONAL DISCLAIMS ANY EXPRESS OR IMPLIED WARRANTY RELATING TO THE SALE AND/OR USE OF NATIONAL PRODUCTS INCLUDING LIABILITY OR WARRANTIES RELATING TO FITNESS FOR A PARTICULAR PURPOSE, MERCHANTABILITY, OR INFRINGEMENT OF ANY PATENT, COPYRIGHT OR OTHER INTELLECTUAL PROPERTY RIGHT.

LIFE SUPPORT POLICY

NATIONAL'S PRODUCTS ARE NOT AUTHORIZED FOR USE AS CRITICAL COMPONENTS IN LIFE SUPPORT DEVICES OR SYSTEMS WITHOUT THE EXPRESS PRIOR WRITTEN APPROVAL OF THE CHIEF EXECUTIVE OFFICER AND GENERAL COUNSEL OF NATIONAL SEMICONDUCTOR CORPORATION. As used herein:

Life support devices or systems are devices which (a) are intended for surgical implant into the body, or (b) support or sustain life and whose failure to perform when properly used in accordance with instructions for use provided in the labeling can be reasonably expected to result in a significant injury to the user. A critical component is any component in a life support device or system whose failure to perform can be reasonably expected to cause the failure of the life support device or system or to affect its safety or effectiveness.

National Semiconductor and the National Semiconductor logo are registered trademarks of National Semiconductor Corporation. All other brand or product names may be trademarks or registered trademarks of their respective holders.

Copyright© 2008 National Semiconductor Corporation

For the most current product information visit us at www.national.com



**National Semiconductor
Americas Technical
Support Center**
Email:
new.feedback@nsc.com
Tel: 1-800-272-9959

**National Semiconductor Europe
Technical Support Center**
Email: europe.support@nsc.com
German Tel: +49 (0) 180 5010 771
English Tel: +44 (0) 870 850 4288

**National Semiconductor Asia
Pacific Technical Support Center**
Email: ap.support@nsc.com

**National Semiconductor Japan
Technical Support Center**
Email: jpn.feedback@nsc.com