

LM2791/2/4/5 Evaluation Board

National Semiconductor
Application Note 1218
Anne Lu
February 2002



Introduction

The LM2791, LM2792, LM2794 and LM2795 are a family of CMOS Current Regulated Switched Capacitor. They are designed to drive white (or blue) LEDs with matched currents to produce balanced light sources for display backlights. The LM2791/2 is offered in a 10 pin Leadless Leadframe (LLP) package. The LM2791/2 is a charge-pump voltage doubler that provides two regulated current sources. The LM2791 delivers up to a total of 36mA through the LEDs with an offset voltage of 200mV at the Iset pin. The LM2792 delivers up to 34mA with zero offset at the Iset to provide fully off to maximum current control. The switching frequency is between 450KHz to 850KHz for the LM2791 and 900KHz to 1800KHz for LM2792. Both devices accept an input volt-

age range of 3V to 5.8V. The LM2791 and the LM2792 are also available in active high and low shutdown versions.

The LM2794/5 is offered in a 14 bump micro-SMD package. LM2794/5 is a fractional charge pump that provides four regulated current sources. The devices deliver up to 80mA with an offset voltage of 188mV at the Iset pin. The switching frequency for both device are 325kHz to 675kHz and the input voltage range is 2.7V to 5.5V. Note that if V_{IN} is greater than 4.5V, the device will switch from charge pump mode to pass mode. During pass mode, the device output (P_{OUT}) will follow V_{IN} . This is done to prevent P_{OUT} from exceeding the package voltage rating if V_{IN} is greater than 4.5V. The LM2794 option offers active low for shutdown while the LM2795 offers active high for shutdown.

Typical Application Circuit

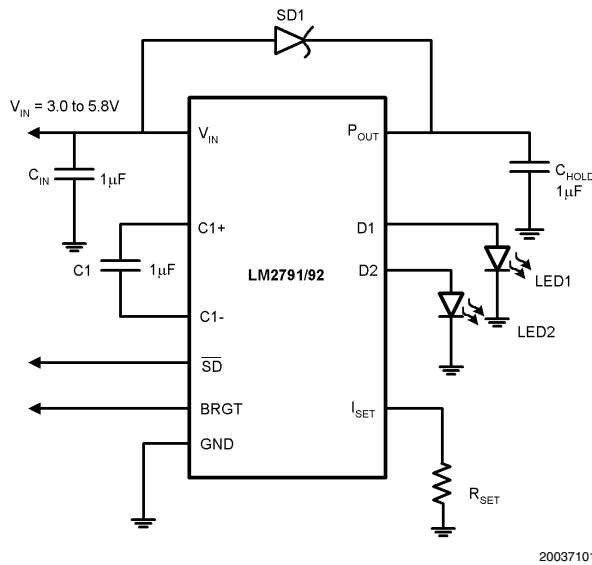

20037101

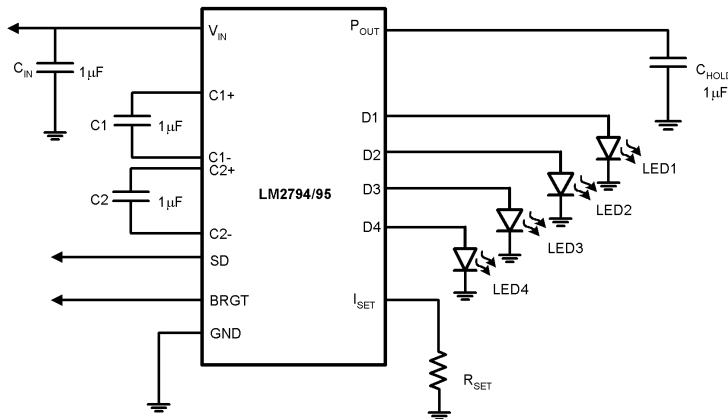

20037102

R_{SET} Selection (LM2791/2)

R_{SET} is the resistor that sets the current through both LEDs. It is left intentionally for the end users to set the desired current range. Equations below are used for determining R_{SET} value:

Eq. 1 for LM2792:

$$R_{SET} = ((0.42 \cdot BRGT) / I_{LED}) \cdot 25$$

Eq. 2 for LM2791:

$$R_{SET} = (((0.42 \cdot BRGT) + 0.200) / I_{LED}) \cdot 25$$

For example, if 15mA is the desired current per LED and BRGT = 3V, using the above equation 1 yields R_{SET} = 2.1K ohms. *Table 1* below shows a typical LED current when BRGT is at 3V(LM2792) maximum and *Table 2* shows a typical LED current when BRGT is at 0V(LM2791). If BRGT voltage is other than 3V, *Table 5* shows R_{SET} and BRGT combination per LED current.

**TABLE 1. R_{SET} when BRGT = 3V
(example given for LM2792)**

I _{LED}	*R _{SET}
15mA	2.1kΩ
10mA	3.15kΩ
5mA	6.3kΩ

* Use 1% resistor for Rset

**TABLE 2. R_{SET} when BRGT = 0V
(example given for LM2791)**

I _{LED}	* R _{SET}
15mA	330Ω
10mA	500Ω
5mA	1KΩ

*Use 1% resistor for Rset

R_{SET} Selection (LM2794/5)

Similar to the LM2791/2, R_{SET} is left intentionally for the end users to set the desired current range. Below is the equation for determining R_{SET} value:

Eq. 3 for LM2794/5:

$$R_{SET} = ((0.188 + (0.385 \cdot BRGT)) / I_{LED}) \cdot 10$$

For example, if 15mA is the desired current per LED and BRGT = 0V (or ground), using the above equation 3 yields R_{SET} = 124 ohms. *Table 3* below shows typical LED current when BRGT is tied to ground and *Table 4* shows typical LED current when BRGT is at 3V maximum. If BRGT is used in the application, *Table 5* shows R_{SET} and BRGT combination per LED current.

TABLE 3. R_{SET} when BRGT = 0V

I _{LED}	R _{SET}
15mA	124Ω
10mA	196Ω
5mA	383Ω

*Rset value is rounded off to the nearest 1% value

TABLE 4. R_{SET} when BRGT = 3V

I _{LED}	*R _{SET}
------------------	-------------------

15mA	909Ω
10mA	1.4KΩ
5mA	2.67Ω

*Rset value is rounded off to the nearest 1% value

BRGT (LM2791/2)

A voltage from 0 to 3V may be applied to the BRGT pin to control the brightness of the LEDs by varying the current through the LEDs. Note that some voltage must be provided at BRGT pin or no current will flow through the LEDs for the LM2792. BRGT pin is connected to an internal resistor divider that gives a factor of 0.42 (LM2792). The product of this factor and the voltage at BRGT is fed to the input of an internal amplifier that sets the current mirror resistor R_{SET}. *Table 5* shows the relationship between LED current with various R_{SET} and BRGT values. Care must be taken to ensure that the voltage at BRGT does not cause LEDs current to exceed a total of 34mA (LM2792). Note that calculations are based on when both D1 and D2 are in use.

**TABLE 5. LED Current When Using BRGT Input
(Example for LM2792 & both D1 & D2 are in use)**

Voltage on BRGT (V)	R _{SET}			
	1000Ω	1500Ω	2000Ω	2500Ω
Current through LED (mA)				
0	0	0	0	0
0.5	5.25	3.5	2.6	2.1
1.0	10.05	7	5.25	4.2
1.5	15.75	10.5	7.88	6.3
2.0	21	14	10.5	8.4
2.5	26.25	17.5	13.1	10.5
3.0	31.5	21	15.75	12.6

(Values Highlighted in **Boldface** exceed maximum current range of the device if both D1 & D2 are in use)

By rearranging equation 1, the following equation can be used to determine I_{LED}:

Eq. 4 for LM2792:

$$I_{LED} = ((0.42 \cdot BRGT) / R_{SET}) \cdot 25$$

Eq. 5 for LM2791:

$$I_{LED} = (((0.42) + 0.200) \cdot BRGT) / R_{SET} \cdot 25$$

BRGT (LM2794/5)

A voltage from 0 to 3V may be applied to the BRGT pin to control the brightness of the LEDs by varying the current through the LEDs. BRGT pin is connected to an internal resistor divider and summed with an offset voltage from the internal bandgap (188mV). This voltage is fed to the input of an internal amplifier that sets the current mirror resistor R_{SET}. *Table 6* below shows the relationship between LED current with various R_{SET} and BRGT values. Care must be taken to ensure that the voltage at BRGT does not cause LEDs current to exceed total of 80mA. By rearranging equation 3, the following equation can be used to determine the I_{LED}:

Eq. 6:

$$I_{LED} = ((0.188 + (0.385 \cdot BRGT)) / R_{SET}) \cdot 10$$

BRGT (LM2794/5) (Continued)**TABLE 6. LED Current When Using BRGT Input**
(D1-D4 are active)

Voltage on BRGT (V)	R_{SET}			
	124 Ω	500 Ω	900 Ω	1750 Ω
Current through LED (mA)				
0	15.16	3.76	2.09	1.07
0.5	30.69	7.61	4.23	2.17
1.0	46.21	11.46	6.37	3.27
1.5	61.73	15.31	8.51	4.37
2.0	77.26	19.16	10.64	5.47
2.5	92.78	23.01	12.78	6.57
3.0	101.88	26.86	14.92	7.67

(Values Highlighted in **Boldface** exceed Maximum current range of the device if all D1-D4 are in use).

Besides adjusting the BRGT pin to control the brightness of the LEDs, SD pin can also be used to control the brightness

by applying a PWM signal at the SD pin and varying the duty cycle. A duty cycle of zero will turn off the device and a 50% duty cycle waveform will produce an average current of 7.5mA if the intended LED(s) current is 15mA.

Shutdown (LM2791/2)

During normal operation, SD pin is connected to V_{IN} (for LM2792LD-H) or connected to ground (for LM2792LD-L). If SD pin is used to control the brightness instead of the BRGT pin, applying a PWM (Pulse Width Modulation) signal in the range of 100Hz to 1KHz is recommended for best result. In the case of the LM2792, connect BRGT to 3V before applying a PWM signal at SD or connect BRGT pin to GND if LM2791 is used),

Shutdown (LM2794/5)

During normal operation, SD pin is connected to V_{IN} (for LM2794) or connected to ground (for LM2795). If SD pin is used to control the brightness instead of the BRGT pin, a PWM signal in the range of 100Hz to 1KHz is recommended.

Components List for LM2791/2

Component Name	Type	Value	Size	Manufacturer
U1	LM2791/2	LM2791/2LD-L	LLP-10	National Semiconductor
C_{IN}	X7R	C2012X7R1C105K, 16V μ F	0805	TDK
C1	X7R	C2012X7R1C105K, 16V μ F	0805	TDK
C_{HOLD}	X7R	C2012X7R1C105K, 16V μ F	0805	TDK
R_{SET}	Through hold	Value to be determined by the end users, +/-1%		
White LEDs	Surface Mount Device, White LEDs (TOPLED)	LWT67C/LWT673		Osram
Schottky Diode	Surface Mount Device	BAT-54 =4P	SOT23-3	Fairchild

LM2791/2 Evaluation Board

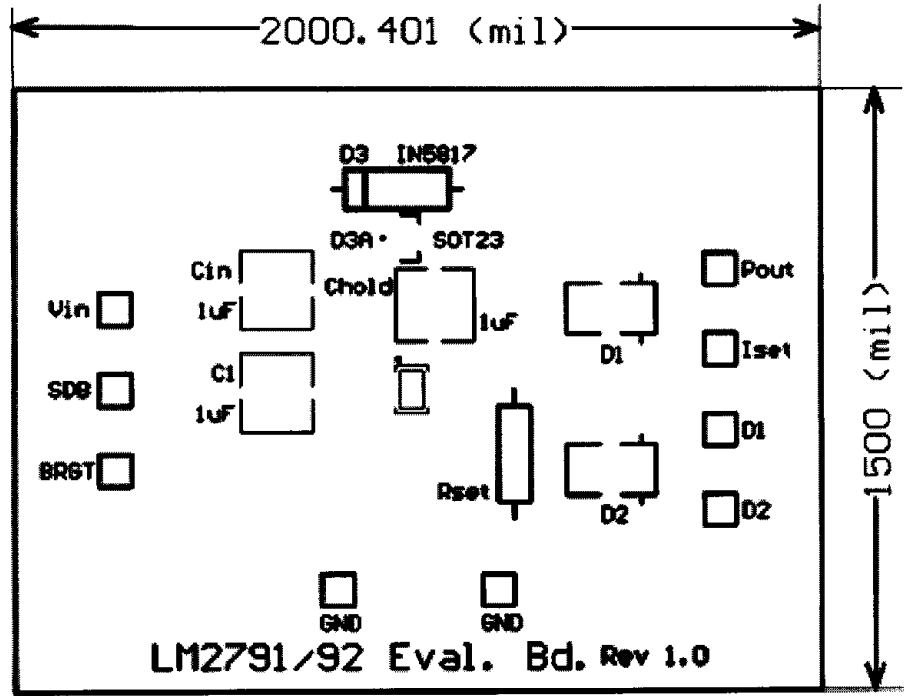

FIGURE 1. Silkscreen

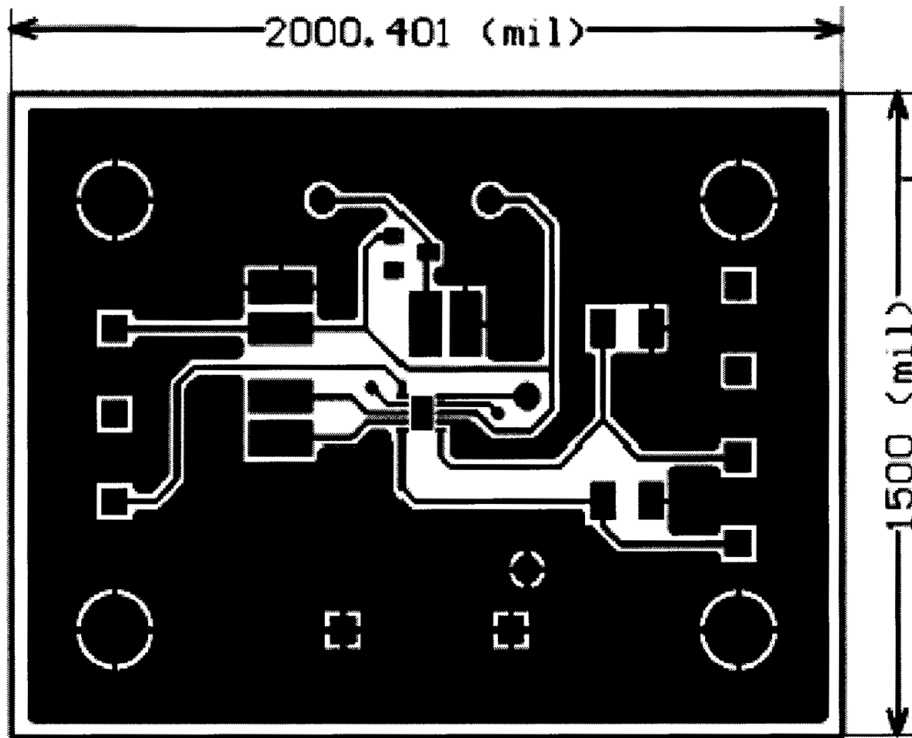
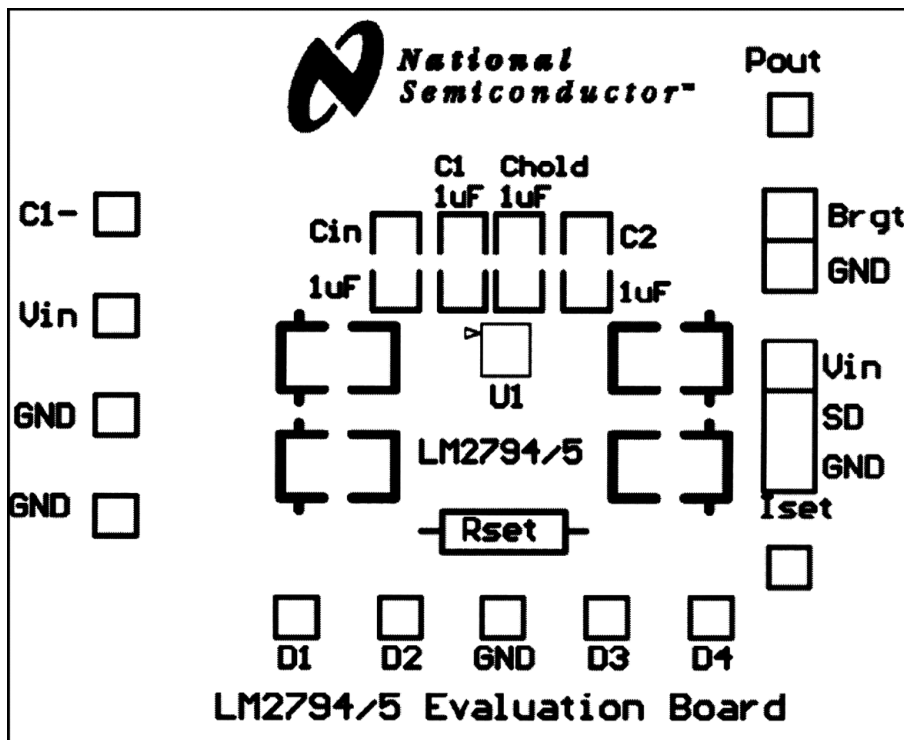

FIGURE 2. PCB Layout

Component List for LM2794/5

Component Name	Type	Value	Size	Manufacturer
U1	LM2794/5	LM2794BL --- Active Low Shutdown LM2795BL --- Active High Shutdown	14 Bump MicroSMD	
C _{IN}	X7R	C2012X7R1C105K, 16V uF	0805	TDK
C1	X7R	C2012X7R1C105K, 16V uF	0805	TDK
C _{HOLD}	X7R	C2012X7R1C105K, 16V uF	0805	TDK
R _{SET}	Through hold	Value to be determined by the end users, +/-1%		
Diode1 - 4	Surface Mount Device, White LEDs (TOPLED)	LWT67C/LWT673	SOT23-3	Osram

LM2794/5 Evaluation Board



20037105

FIGURE 3. Silkscreen

LM2794/5 Evaluation Board (Continued)

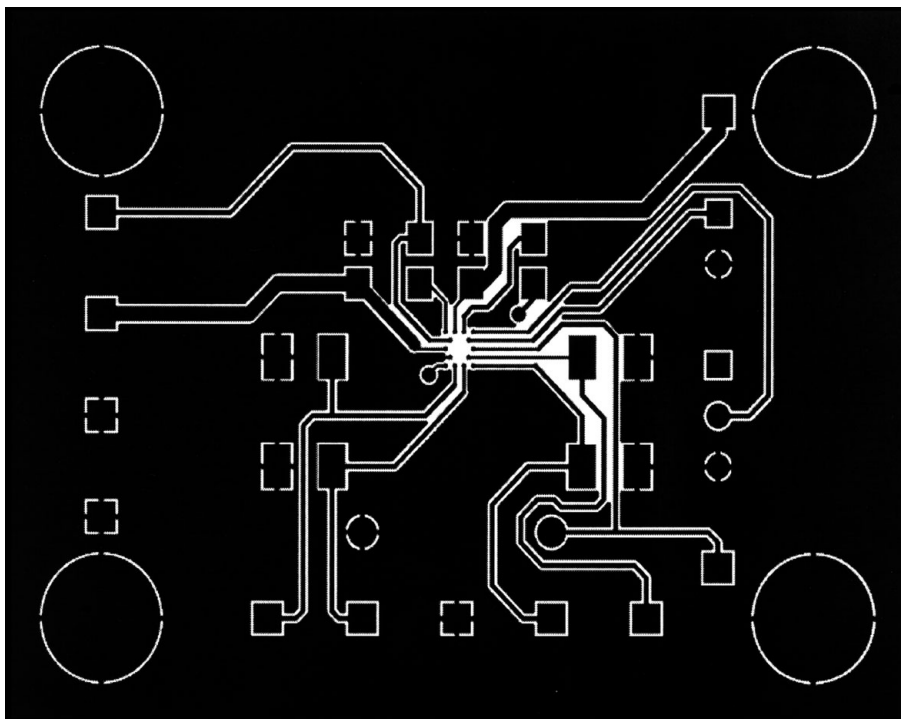

20037106

FIGURE 4. PCB Layout

LIFE SUPPORT POLICY

NATIONAL'S PRODUCTS ARE NOT AUTHORIZED FOR USE AS CRITICAL COMPONENTS IN LIFE SUPPORT DEVICES OR SYSTEMS WITHOUT THE EXPRESS WRITTEN APPROVAL OF THE PRESIDENT AND GENERAL COUNSEL OF NATIONAL SEMICONDUCTOR CORPORATION. As used herein:

1. Life support devices or systems are devices or systems which, (a) are intended for surgical implant into the body, or (b) support or sustain life, and whose failure to perform when properly used in accordance with instructions for use provided in the labeling, can be reasonably expected to result in a significant injury to the user.
2. A critical component is any component of a life support device or system whose failure to perform can be reasonably expected to cause the failure of the life support device or system, or to affect its safety or effectiveness.



National Semiconductor Corporation
Americas
Email: support@nsc.com

www.national.com

National Semiconductor Europe

Fax: +49 (0) 180-530 85 86
Email: europe.support@nsc.com
Deutsch Tel: +49 (0) 69 9508 6208
English Tel: +44 (0) 870 24 0 2171
Français Tel: +33 (0) 1 41 91 8790

National Semiconductor Asia Pacific Customer Response Group

Tel: 65-2544466
Fax: 65-2504466
Email: ap.support@nsc.com

National Semiconductor Japan Ltd.

Tel: 81-3-5639-7560
Fax: 81-3-5639-7507