

# LM3402/02HV Demo Board

National Semiconductor  
Application Note 1500  
Chris Richardson  
June 2007



## Introduction

The LM3402/LM3402HV is a buck regulator derived controlled current source designed to drive a series string of high power, high brightness LEDs (HBLEDs) such as the Luxeon™ I Emitter at forward currents of up to 500 mA. The board can accept an input voltage ranging from 6V to 42V when using the LM3402. When using the pin-for-pin compatible LM3402HV the upper bound of input voltage is 75V. The converter output voltage adjusts as needed to maintain a constant current through the LED array. The LM3402/02HV is a true step-down regulator with an output voltage range extending from a  $V_{O(MIN)}$  of 200 mV (the reference voltage) to a  $V_{O(MAX)}$  determined by the minimum off time (typically 300 ns). It can maintain regulated current through any number of LEDs as long as the combined forward voltage of the array does not exceed  $V_{O(MAX)}$ .

## Circuit Performance LM3402

The LM3402 circuit and BOM have been designed to provide a constant forward current of 350 mA to a single LED with a forward voltage of approximately 3.5V. (Typical of white, blue, and green LEDs using InGaN technology.) When powered from a  $24V \pm 5\%$  input the demo board will maintain the average LED current,  $I_F$ , to within 10% of 350 mA. The ripple current,  $\Delta i_F$ , will not exceed 70 mA peak-to-peak. Switching frequency for the demo board is  $600 \text{ kHz} \pm 10\%$  over the input voltage range of 6V to 42V.

## Circuit Performance LM3402HV

The LM3402HV circuit and BOM have been designed to provide a constant forward current of 350 mA to a single LED with a forward voltage of approximately 3.5V. When powered from a  $48V \pm 5\%$  input the demo board will maintain  $I_F$  to within  $\pm 5\%$  of 350 mA. Ripple current will not exceed 70 mA peak-to-peak. Switching frequency for the demo board is  $250 \text{ kHz} \pm 10\%$  over the input voltage range of 6V to 75V.

## Connecting to LED Array

The LM3402/02HV demo board includes a female 6-pin SIP, **J1**, connector as well as two standard 94mil turret connectors for the cathode and anode connections of the LED array. Figure 1 shows the pinout of **J1**. Solid, 18 or 20 gauge wire with about 1 cm of insulation stripped away makes a convenient, solderless connection to **J1**.

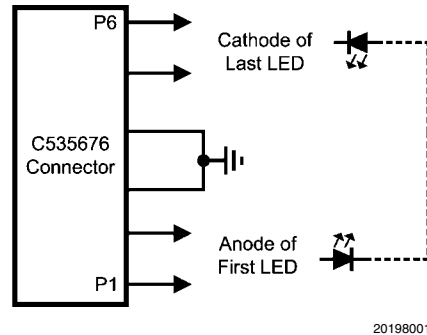

FIGURE 1.

## Setting the LED Current

The default forward current  $I_{LED}$  delivered to the LED array is 350 mA, typical of many 1W LEDs. To adjust this value the current setting resistor  $R_{SNS}$  can be changed according to the following equation:

$$R_{SNS} = \frac{0.2 \times L}{I_F \times L + V_O \times t_{SNS} - \frac{V_{IN} - V_O}{2} \times t_{ON}}$$

$$t_{SNS} = 220 \text{ ns}$$

This resistor should be rated to handle the power dissipation of the LED current. For example, the closest 5% tolerance resistor to set an LED current of 350 mA is  $0.56 \Omega$ . In steady state this resistor will dissipate  $(0.352 \times 0.56) = 69 \text{ mW}$ , indicating that a resistor with a 1/8W power rating is appropriate.

## PWM Dimming

The **DIM1** terminal on the PCB provides an input for a pulse width modulation signal for dimming of the LED array. In order to fully enable and disable the LM3402/02HV the PWM signal should have a maximum logic low level of 0.8V and a minimum logic high level of 2.2V. The maximum PWM dimming frequency, minimum PWM duty cycle and maximum duty cycle are illustrated in Figure 2. PWM frequency should be at least one order of magnitude below the LM3402/02HV switching frequency. The interval  $t_D$  represents the delay from a logic high at the DIM pin to the onset of the output current. The quantities  $t_{SU}$  and  $t_{SD}$  represent the time needed for the output current to slew up to steady state and slew down to zero, respectively. Typical response times for the standard LM3402 and LM3402HV demo boards circuits are shown in the Typical Performance Characteristics section.

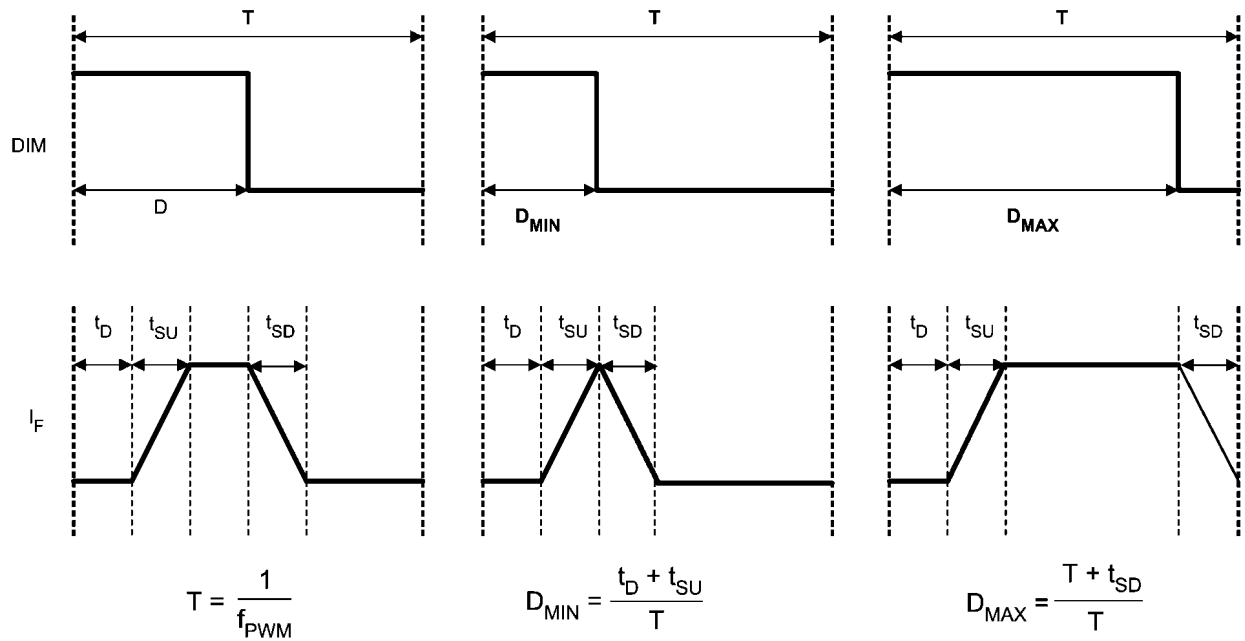

20198002

FIGURE 2. PWM Dimming Limits

The logic of **DIM1** is direct, hence the LM3402/02HV will deliver regulated output current when the voltage at **DIM1** is high, and the current output is disabled when the voltage at **DIM1** is low. Connecting a constant logic low will disable the output, and the LM3402/02HV is enabled if the DIM pin is open-circuited. The **DIM1** function disables only the power NFET, leaving all other circuit blocks functioning to minimize the converter response time.

The **DIM2** terminal provides a second method for PWM dimming by connecting to the gate of an optional NFET, **Q1**. Note that **Q1** is not provided on the standard BOM, and must be added for the **DIM2** function to operate. **Q1** provides a parallel path for the LED current. This small NFET can be turned on and off much more quickly than the LM3402/02HV can shut down the internal NFET, providing faster response time for higher frequency and/or greater resolution in the PWM dimming signal. The tradeoff in this method is that the full current flows through **Q1** while the LED is off, resulting in lower efficiency.

The logic of **DIM2** is inverted, hence the LM3402/02HV will deliver regulated output current when the voltage at **DIM2** is low, and the current output is disabled when the voltage at **DIM2** is high. Connecting a constant logic high to the **DIM2** will turn off the LED but will not shut down the LM3402/02HV.

## Low Power Shutdown

The LM3402/02HV can be placed into a low power shutdown (typically 90  $\mu$ A) by grounding the **OFF\*** terminal. During normal operation this terminal should be left open-circuit.

## Output Open Circuit

With either DIM terminal floating or connected to logic high, the LM3402/02HV will begin to operate as soon as it has an input of at least 6V. In the case that the input is powered but no LED array is connected the output voltage will rise to equal the input voltage. The output of the circuit is rated to 50V (LM3402) or 100V (LM3402HV) and will not suffer damage, however care should be taken not to connect an LED array if the output voltage is higher than the target forward voltage of the LED array in steady state. Alternatively, a zener diode and zener current limiting resistor can be placed in the positions **Z1** and **Rz**. In the case of an accidental open circuit at the output **Z1** will enter reverse bias and attempt to pull the CS pin voltage up to the output voltage. An internal comparator monitors the CS pin voltage and will disable the internal NFET in this case. The result is a low power hiccup mode, designed to prevent excessive voltage at the output and thermal stress on the inductor, internal NFET, and input voltage source.

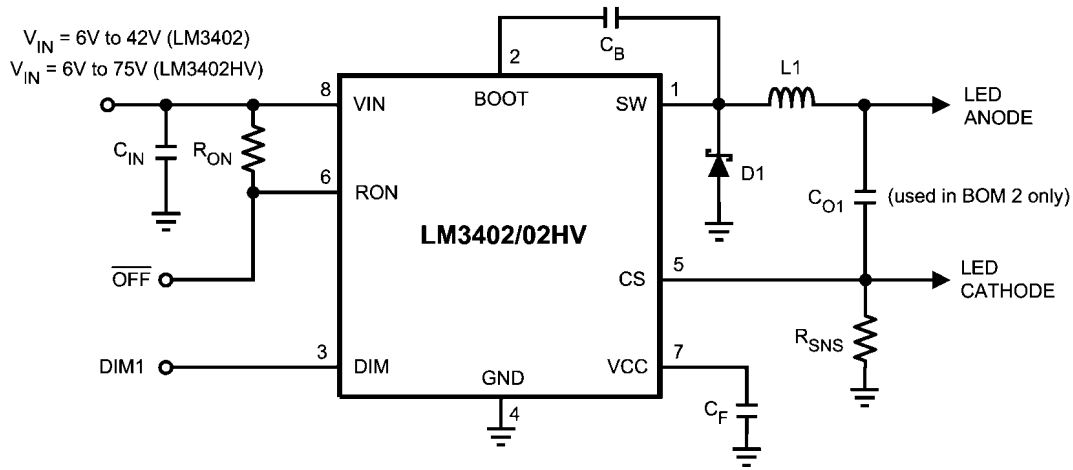

FIGURE 3. Standard Schematic

TABLE 1. BOM 1 (LM3402)

ID	Part Number	Type	Size	Parameters	Qty	Vendor
U1	LM3402	LED Driver	MSOP-8	42V, 0.5A	1	NSC
L1	SLF10145T-101M1R0	Inductor	10.1 x 10.1 x 4.5mm	100 $\mu$ H, 1A, 0.2 $\Omega$	1	TDK
D1	CMSH1-60M	Schottky Diode	SMA	60V, 1A	1	Central Semi
Cf	VJ0805Y104KXXAT	Capacitor	0805	100nF 10%	1	Vishay
Cb	VJ0805Y103KXXAT	Capacitor	0805	10nF 10%	1	Vishay
Cin	C3216X7R1H105M	Capacitor	1206	1 $\mu$ F 50V	1	TDK
Rsns	ERJ6BQFR56V	Resistor	0805	0.56 $\Omega$ 1%	1	Panasonic
Ron	CRCW08054642F	Resistor	0805	46.4k $\Omega$ 1%	1	Vishay
Rz	CRCW08050R00F	Resistor	0805	0 $\Omega$	1	Vishay
DIM1, DIM2	160-1512	Terminal Silver	0.062"		2	Cambion
GND1, GND2, GND3, VIN, ISNS / C, Vo / A, SW	160-1026	Terminal Silver	0.094"		7	Cambion
J1	535676-5	Connector	Custom	6 Pins	1	Tyco/AMP

TABLE 2. BOM 2 (LM3402HV)

ID	Part Number	Type	Size	Parameters	Qty	Vendor
U1	LM3402HV	LED Driver	MSOP-8	75V, 0.5A	1	NSC
L1	SLF10145T-151MR79	Inductor	10.1 x 10.1 x 4.5mm	150 $\mu$ H, 0.8A, 0.2 $\Omega$	1	TDK
D1	CMSH1-100M	Schottky Diode	SMA	100V, 1A	1	Central Semi
Cf	VJ0805Y104KXXAT	Capacitor	0805	100nF 10%	1	Vishay
Cb	VJ0805Y103KXXAT	Capacitor	0805	10nF 10%	1	Vishay
Cin	C3225X7R2A105M	Capacitor	1210	1 $\mu$ F 100V	1	TDK
Co1	C3216X7R1E225M	Capacitor	1206	2.2 $\mu$ F 25V	1	TDK
Rsns	ERJ6BQFR68V	Resistor	0805	0.68 $\Omega$ 1%	1	Panasonic
Ron	CRCW08051303F	Resistor	0805	130k $\Omega$ 1%	1	Vishay
Rz	CRCW08050R00F	Resistor	0805	0 $\Omega$	1	Vishay
DIM1, DIM2	160-1512	Terminal Silver	0.062"		2	Cambion
GND1, GND2, GND3, VIN, ISNS / C, Vo / A, SW	160-1026	Terminal Silver	0.094"		7	Cambion
J1	535676-5	Connector	Custom	6 Pins	1	Tyco/AMP

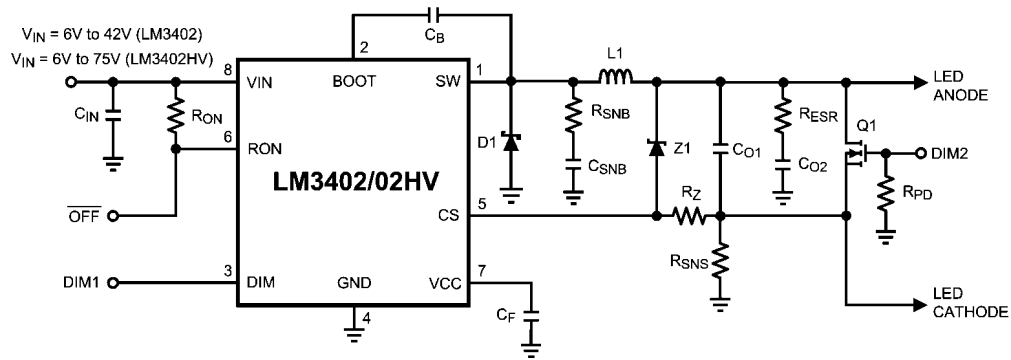

20198005

FIGURE 4. Complete Evaluation Board Schematic

# Typical Performance Characteristics

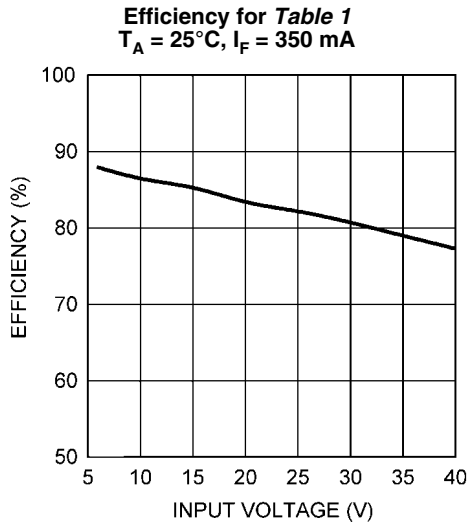

20198008

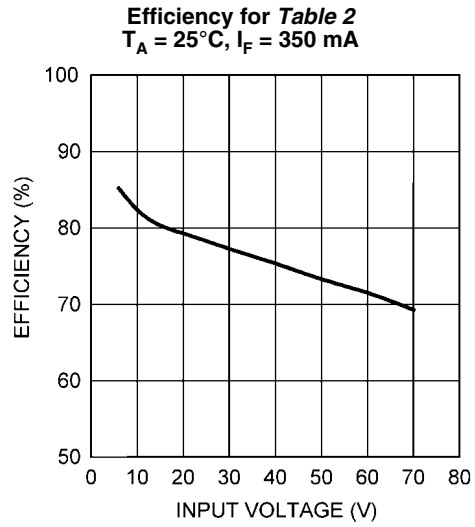

20198009

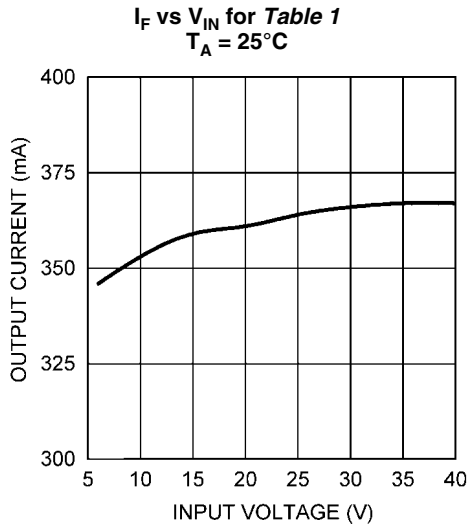

20198010

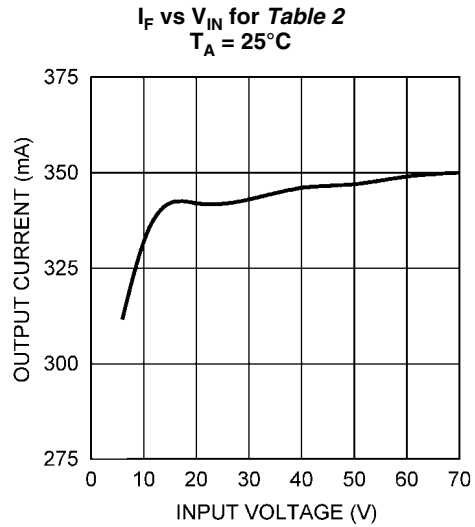

20198011

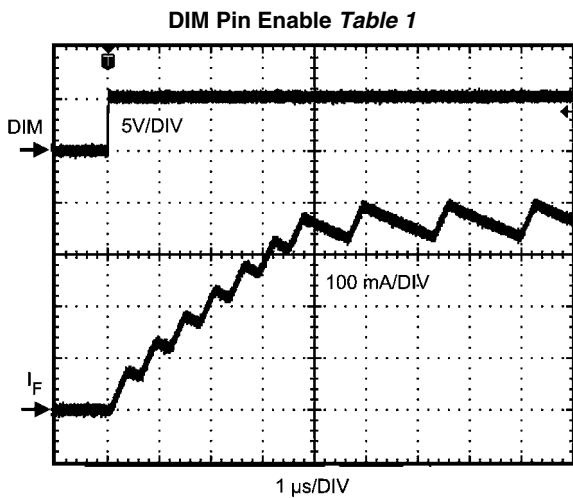

20198012

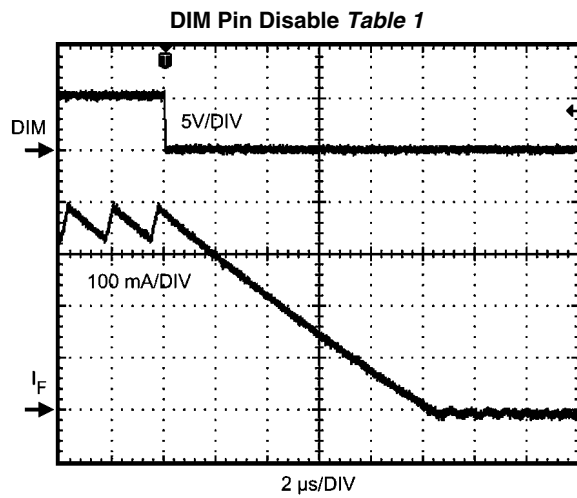

20198013

Switching Waveforms for Table 1

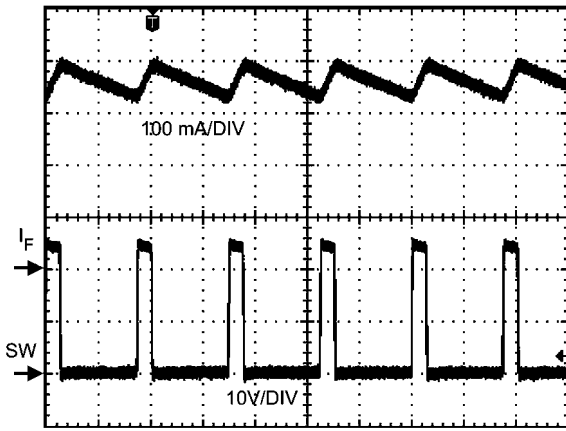

1  $\mu$ s/DIV

20198014

Output Ripple Current Table 1

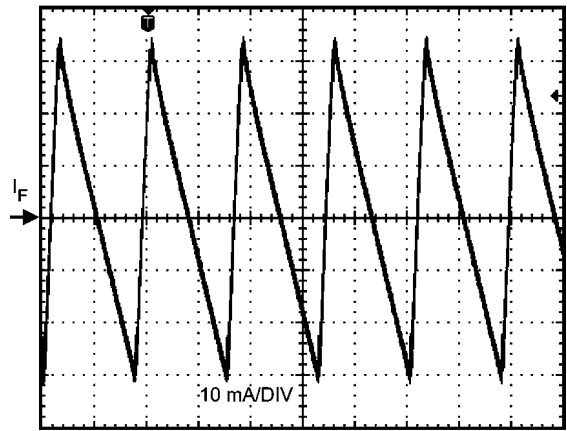

1  $\mu$ s/DIV

20198015

DIM Pin Enable Table 2

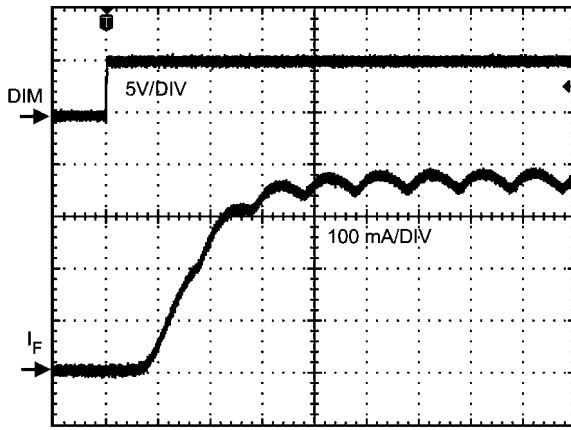

4  $\mu$ s/DIV

20198016

DIM Pin Disable Table 2

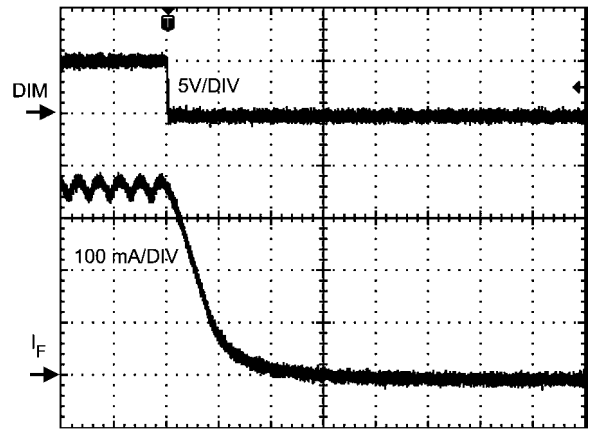

10  $\mu$ s/DIV

20198017

Switching Waveforms for Table 2

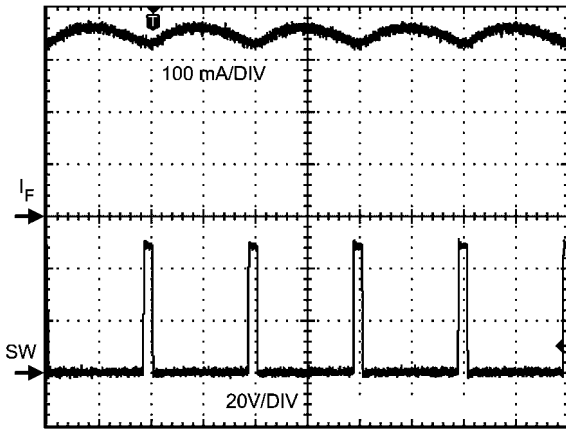

2  $\mu$ s/DIV

20198018

Output Ripple Current Table 2

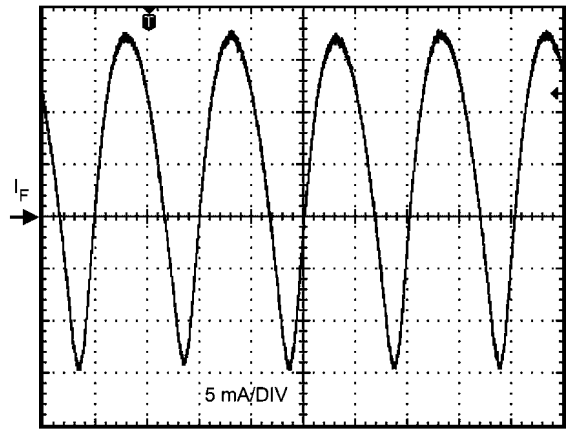

2  $\mu$ s/DIV

20198019

# Layout

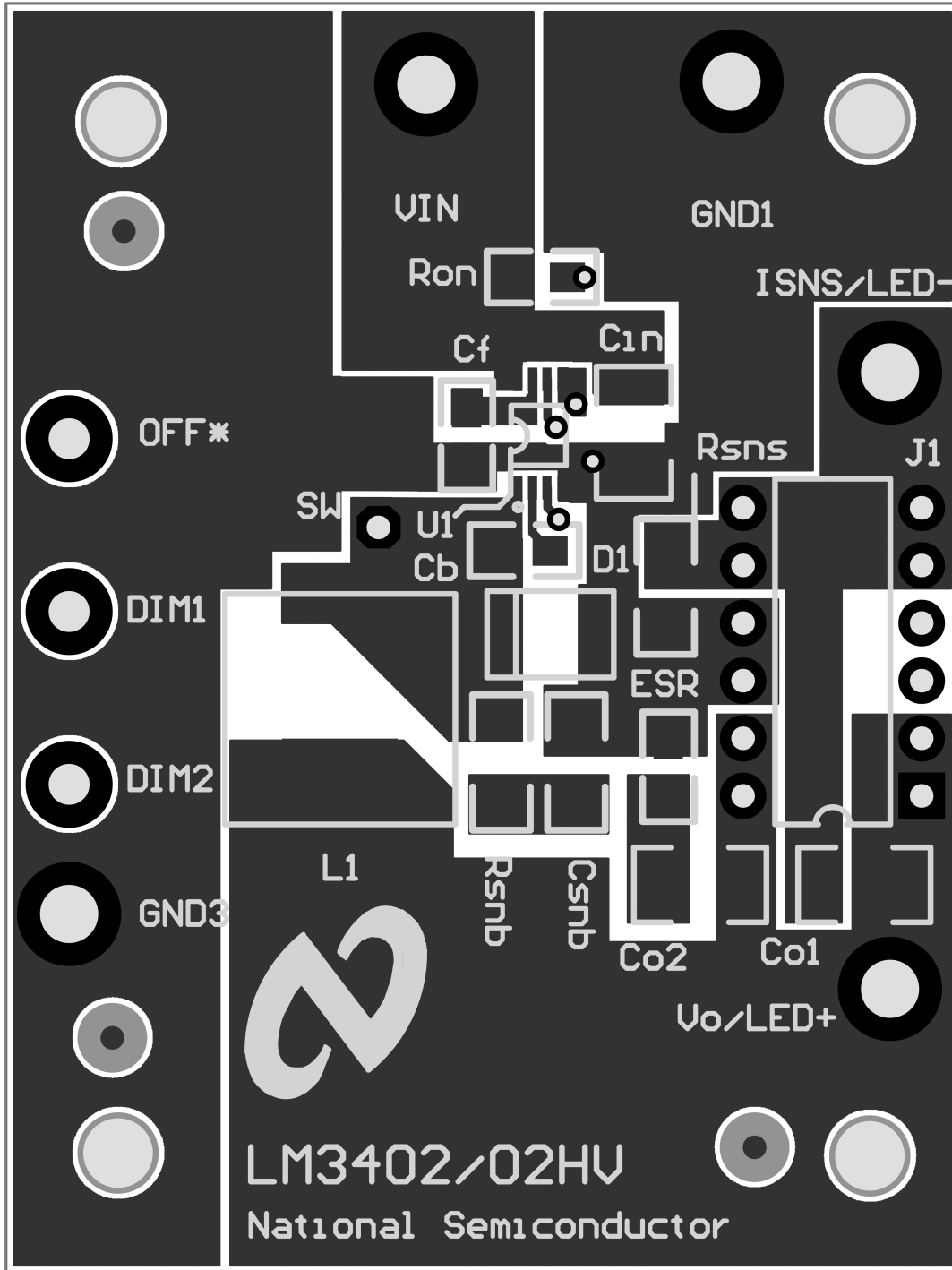

Top Layer and Top Overlay

20198006

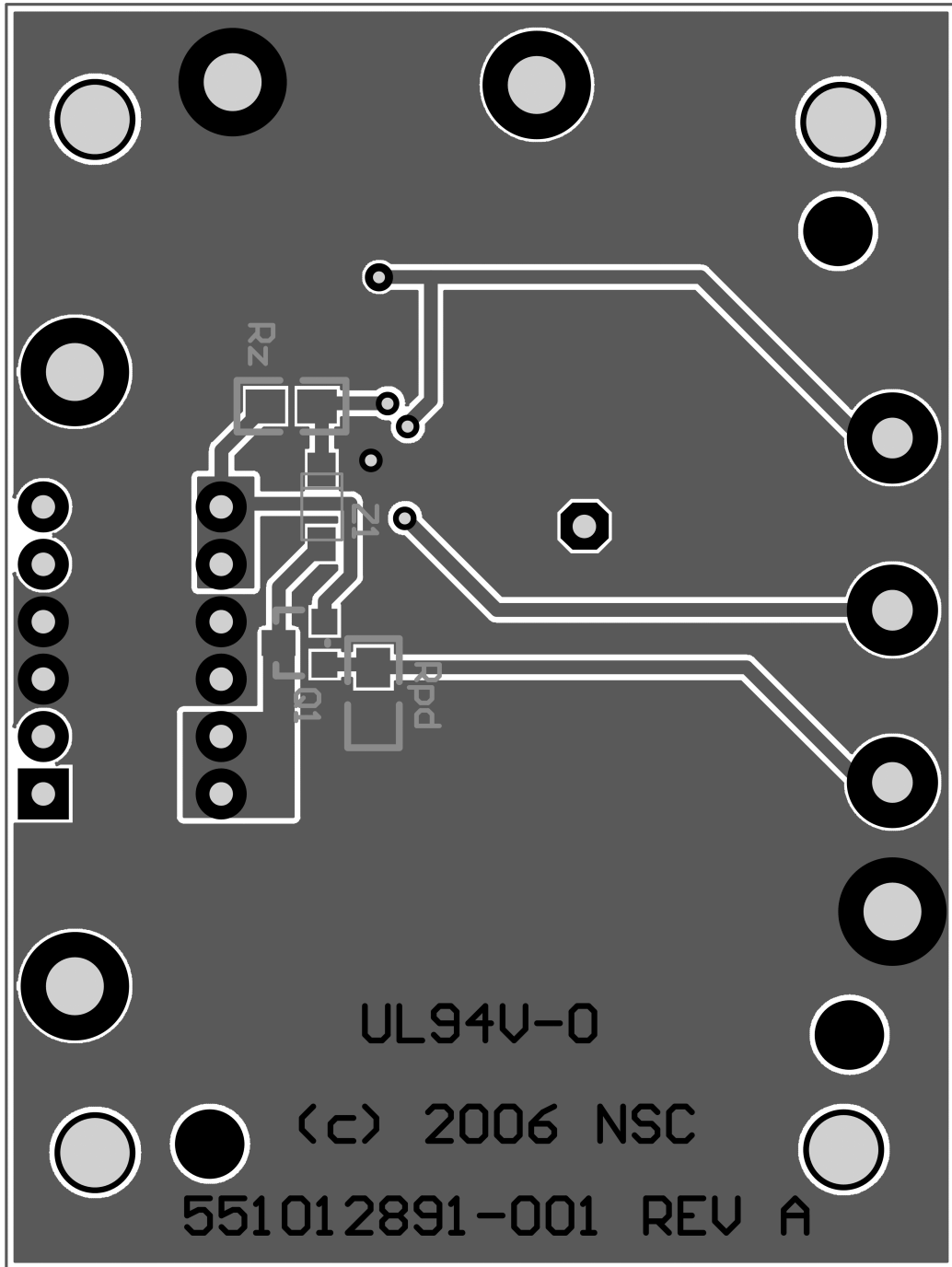

Bottom Layer and Bottom Overlay

20198007



# Notes

AN-1500

## Notes

THE CONTENTS OF THIS DOCUMENT ARE PROVIDED IN CONNECTION WITH NATIONAL SEMICONDUCTOR CORPORATION ("NATIONAL") PRODUCTS. NATIONAL MAKES NO REPRESENTATIONS OR WARRANTIES WITH RESPECT TO THE ACCURACY OR COMPLETENESS OF THE CONTENTS OF THIS PUBLICATION AND RESERVES THE RIGHT TO MAKE CHANGES TO SPECIFICATIONS AND PRODUCT DESCRIPTIONS AT ANY TIME WITHOUT NOTICE. NO LICENSE, WHETHER EXPRESS, IMPLIED, ARISING BY ESTOPPEL OR OTHERWISE, TO ANY INTELLECTUAL PROPERTY RIGHTS IS GRANTED BY THIS DOCUMENT.

TESTING AND OTHER QUALITY CONTROLS ARE USED TO THE EXTENT NATIONAL DEEMS NECESSARY TO SUPPORT NATIONAL'S PRODUCT WARRANTY. EXCEPT WHERE MANDATED BY GOVERNMENT REQUIREMENTS, TESTING OF ALL PARAMETERS OF EACH PRODUCT IS NOT NECESSARILY PERFORMED. NATIONAL ASSUMES NO LIABILITY FOR APPLICATIONS ASSISTANCE OR BUYER PRODUCT DESIGN. BUYERS ARE RESPONSIBLE FOR THEIR PRODUCTS AND APPLICATIONS USING NATIONAL COMPONENTS. PRIOR TO USING OR DISTRIBUTING ANY PRODUCTS THAT INCLUDE NATIONAL COMPONENTS, BUYERS SHOULD PROVIDE ADEQUATE DESIGN, TESTING AND OPERATING SAFEGUARDS.

EXCEPT AS PROVIDED IN NATIONAL'S TERMS AND CONDITIONS OF SALE FOR SUCH PRODUCTS, NATIONAL ASSUMES NO LIABILITY WHATSOEVER, AND NATIONAL DISCLAIMS ANY EXPRESS OR IMPLIED WARRANTY RELATING TO THE SALE AND/OR USE OF NATIONAL PRODUCTS INCLUDING LIABILITY OR WARRANTIES RELATING TO FITNESS FOR A PARTICULAR PURPOSE, MERCHANTABILITY, OR INFRINGEMENT OF ANY PATENT, COPYRIGHT OR OTHER INTELLECTUAL PROPERTY RIGHT.

### LIFE SUPPORT POLICY

**NATIONAL'S PRODUCTS ARE NOT AUTHORIZED FOR USE AS CRITICAL COMPONENTS IN LIFE SUPPORT DEVICES OR SYSTEMS WITHOUT THE EXPRESS PRIOR WRITTEN APPROVAL OF THE CHIEF EXECUTIVE OFFICER AND GENERAL COUNSEL OF NATIONAL SEMICONDUCTOR CORPORATION.** As used herein:

Life support devices or systems are devices which (a) are intended for surgical implant into the body, or (b) support or sustain life and whose failure to perform when properly used in accordance with instructions for use provided in the labeling can be reasonably expected to result in a significant injury to the user. A critical component is any component in a life support device or system whose failure to perform can be reasonably expected to cause the failure of the life support device or system or to affect its safety or effectiveness.

National Semiconductor and the National Semiconductor logo are registered trademarks of National Semiconductor Corporation. All other brand or product names may be trademarks or registered trademarks of their respective holders.

Copyright© 2007 National Semiconductor Corporation

For the most current product information visit us at [www.national.com](http://www.national.com)



**National Semiconductor Americas Customer Support Center**  
 Email: [new.feedback@nsc.com](mailto:new.feedback@nsc.com)  
 Tel: 1-800-272-9959

**National Semiconductor Europe Customer Support Center**  
 Fax: +49 (0) 180-530-85-86  
 Email: [europe.support@nsc.com](mailto:europe.support@nsc.com)  
 Deutsch Tel: +49 (0) 69 9508 6208  
 English Tel: +49 (0) 870 24 0 2171  
 Français Tel: +33 (0) 1 41 91 8790

**National Semiconductor Asia Pacific Customer Support Center**  
 Email: [ap.support@nsc.com](mailto:ap.support@nsc.com)

**National Semiconductor Japan Customer Support Center**  
 Fax: 81-3-5639-7507  
 Email: [jpn.feedback@nsc.com](mailto:jpn.feedback@nsc.com)  
 Tel: 81-3-5639-7560