

# LM3410X LED Driver 5-Pin SOT-23 Demo Board

National Semiconductor  
 Application Note 1773  
 Matthew Reynolds  
 January 31, 2008



## Introduction

The demo board included in this shipment converts 2.7V to 5.5V input, and illuminates four 50mA LED's in series using the LM3410X 1.6MHz LED driver switching converter. This is a 2-layer board using the bottom layer as a Ground plane. A bill of materials below describes the parts used on this demo board. A schematic and layout have also been included below

along with measured performance characteristics. The above restrictions for the input voltage are valid only for the demo board as shipped with the demo board schematic below.

### Operating Conditions

$V_{IN} = 2.7V$  to  $5.5V$   
 $V_O \approx V_F \times 4 + V_{FB} \approx 3.6V \times 4 + 0.198V \approx 14.4V$   
 $I_O = 50mA$

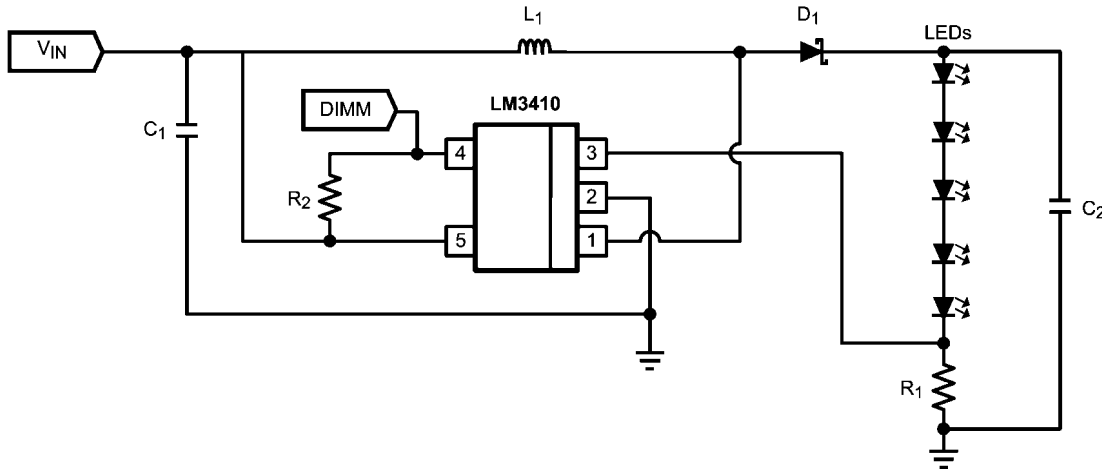

LM3410X 5-Pin SOT23 Schematic

30048701

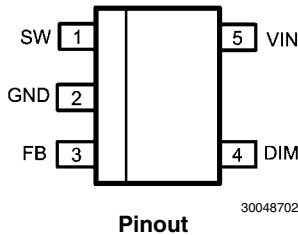

30048702

## Pin Descriptions - 5-Pin SOT23

Pin	Name	Function
1	SW	Output switch. Connect to the inductor, output diode.
2	GND	Signal and power ground pin. Place the bottom resistor of the feedback network as close as possible to this pin.
3	FB	Feedback pin. Connect FB to external resistor divider to set output voltage.
4	DIM	Dimming & shutdown control input. Logic high enables operation. Duty Cycle from 0 to 100%. Do not allow this pin to float or be greater than $V_{IN} + 0.3V$ .
5	VIN	Supply voltage pin for power stage, and input supply voltage.

## Bill of Materials LM3410X

Part ID	Part Value	Manufacturer	Part Number
U1	2.8A $I_{SW}$ LED Driver	NSC	LM3410XMF
C1, Input Cap	10 $\mu$ F, 6.3V, X5R	TDK	C2012X5R0J106M
C2 Output Cap	2.2 $\mu$ F, 25V, X5R	TDK	C2012X5R1E225M
D1, Catch Diode	0.4V <sub>f</sub> Schottky 500mA, 30VR	Diodes Inc	MBR0530
L1	10 $\mu$ H 1.2A	Coilcraft	DO1608C-103
R1	4.02 $\Omega$ , 1% $\Omega$	Vishay	CRCW08054R02FRT1
R2	100k $\Omega$ , 1%	Vishay	CRCW06031003F
LED's	SMD-1206, 50mA, V <sub>f</sub> $\approx$ 3.6V	Lite-On	LTW-150k

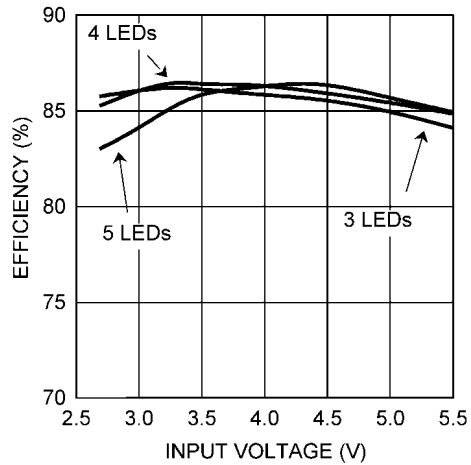

<sup>30048703</sup>  
LM3410X Efficiency vs Input Voltage Series LEDs @ 50mA

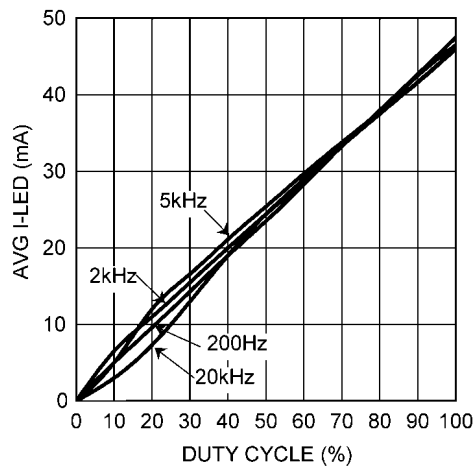

<sup>30048704</sup>  
LM3410X Average LED Current vs Duty-Cycle & Dimming Frequency

# PCB Layout

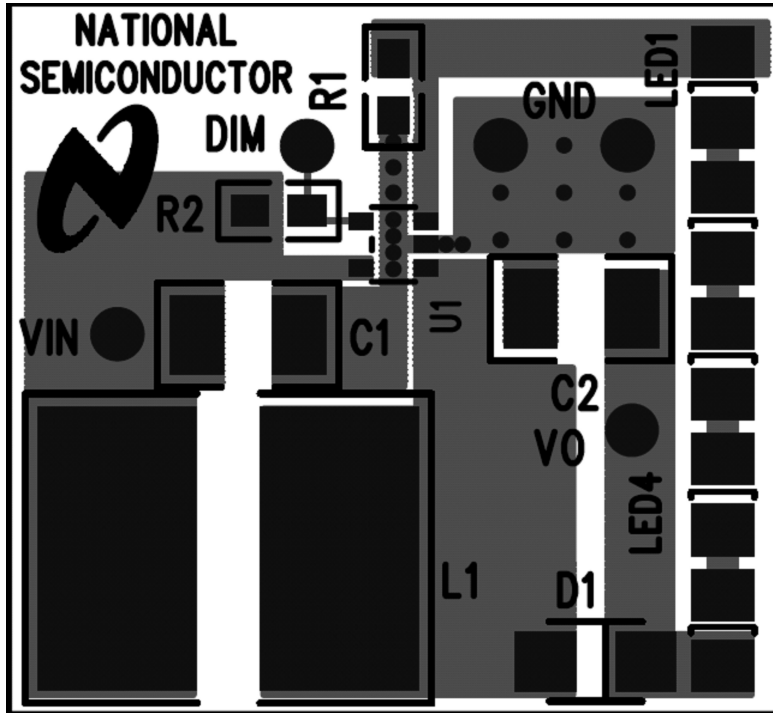

Demonstration Board Top Layer

30048705

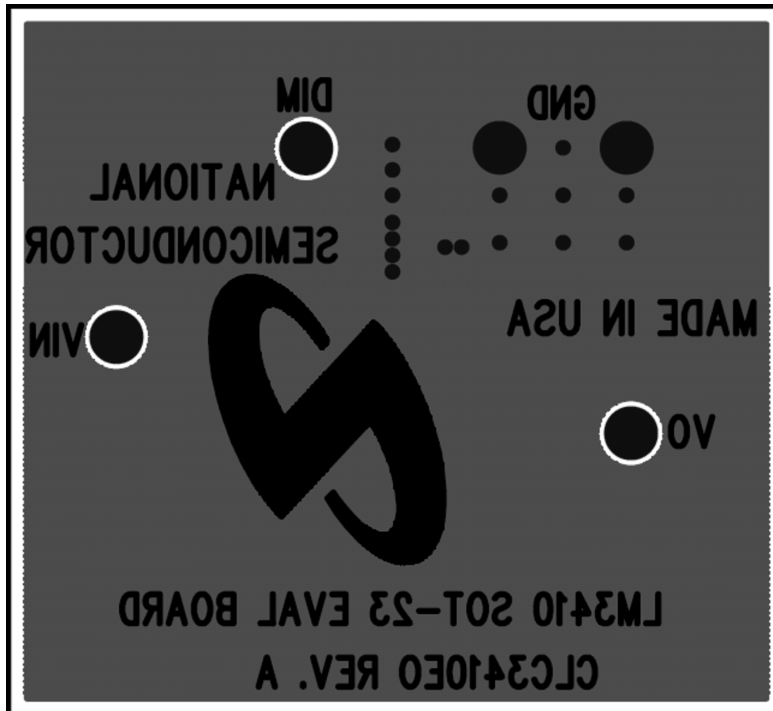

Demonstration Board Bottom Layer

30048706

## 16V > $V_{PWR}$ > 5.5V Application Circuit

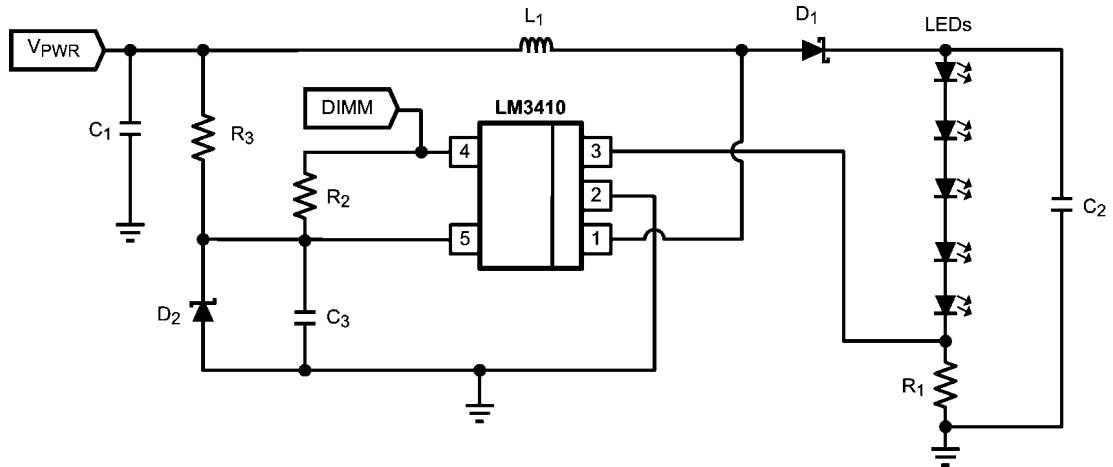

30048707

FIGURE 1.

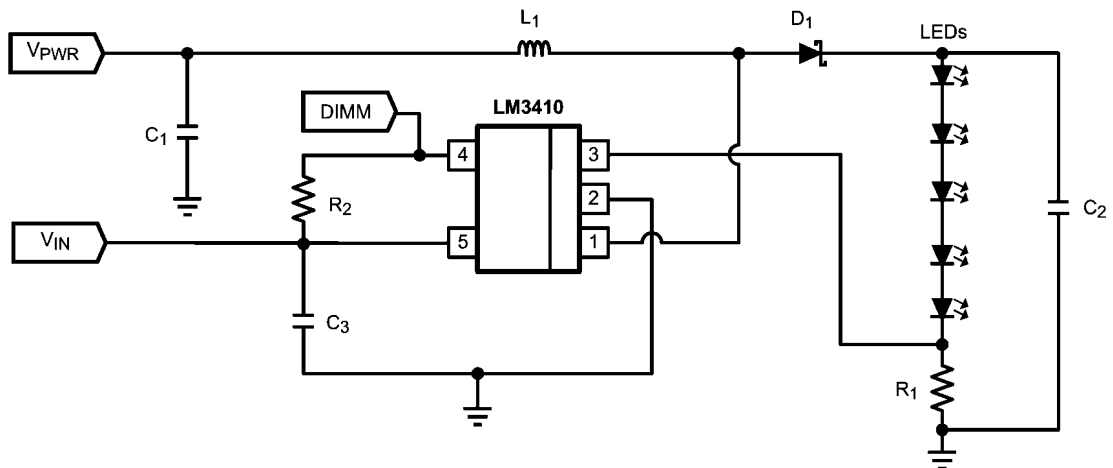

30048708

FIGURE 2.

The circuit shown in *Figure 1* allows for a single supply to be used with a simple zener diode regulation circuit to provide the LM3410 with a housekeeping and driver voltage that is below 5.5V.

The demonstration board provided can easily be modified to allow the user to derive the power from an input supply that

is larger than 5.5V. In *Figure 2* two separate supplies are needed.  $V_{IN}$  must be between 2.7V minimum to 5.5V maximum, but  $V_{PWR}$  can be as great as 16V.

The LM3410  $V_{IN}$  supply will draw approximately 7 mA while it is switching. Zener diode should have a breakdown voltage lower than 5V, and size R3 to allow for 7 mA of current draw.

Part ID	Part Value	Manufacturer	Part Number
U1	2.8A $I_{SW}$ LED Driver	NSC	LM3410XMF
C1 $V_{PWR}$ Input Cap	10 $\mu$ F, 6.3V, X5R	TDK	C1608X5R0J106K
C2 Output Cap	1 $\mu$ F, 25V, X5R	TDK	C2012X5R1E105K
C3 $V_{IN}$ Input Cap	0.1 $\mu$ F, 6.3V, X5R	TDK	C1005X5R1C104K
D1, Catch Diode	0.43V <sub>f</sub> , Schotky, 0.5A, 30V <sub>R</sub>	Diodes Inc	B0530W
L1	6.8 $\mu$ H 2.7A	Coilcraft	MOS6020-682
R1	4.02 $\Omega$ , 1%	Vishay	CRCW08054R02FRT1
R2	100k $\Omega$ , 1%	Vishay	CRCW08051003F
R3	576 $\Omega$ , 1%	Vishay	CRCW08055760F
D2	3.3V Zener, SOT23	Diodes Inc	BZX84C3V3
LEDs	SMD-1206, 50mA, $V_f \approx 3.6V$		

For more National Semiconductor product information and proven design tools, visit the following Web sites at:

Products		Design Support	
Amplifiers	<a href="http://www.national.com/amplifiers">www.national.com/amplifiers</a>	WEBENCH	<a href="http://www.national.com/webench">www.national.com/webench</a>
Audio	<a href="http://www.national.com/audio">www.national.com/audio</a>	Analog University	<a href="http://www.national.com/AU">www.national.com/AU</a>
Clock Conditioners	<a href="http://www.national.com/timing">www.national.com/timing</a>	App Notes	<a href="http://www.national.com/appnotes">www.national.com/appnotes</a>
Data Converters	<a href="http://www.national.com/adc">www.national.com/adc</a>	Distributors	<a href="http://www.national.com/contacts">www.national.com/contacts</a>
Displays	<a href="http://www.national.com/displays">www.national.com/displays</a>	Green Compliance	<a href="http://www.national.com/quality/green">www.national.com/quality/green</a>
Ethernet	<a href="http://www.national.com/ethernet">www.national.com/ethernet</a>	Packaging	<a href="http://www.national.com/packaging">www.national.com/packaging</a>
Interface	<a href="http://www.national.com/interface">www.national.com/interface</a>	Quality and Reliability	<a href="http://www.national.com/quality">www.national.com/quality</a>
LVDS	<a href="http://www.national.com/lvds">www.national.com/lvds</a>	Reference Designs	<a href="http://www.national.com/refdesigns">www.national.com/refdesigns</a>
Power Management	<a href="http://www.national.com/power">www.national.com/power</a>	Feedback	<a href="http://www.national.com/feedback">www.national.com/feedback</a>
Switching Regulators	<a href="http://www.national.com/switchers">www.national.com/switchers</a>		
LDOs	<a href="http://www.national.com/ldo">www.national.com/ldo</a>		
LED Lighting	<a href="http://www.national.com/led">www.national.com/led</a>		
PowerWise	<a href="http://www.national.com/powerwise">www.national.com/powerwise</a>		
Serial Digital Interface (SDI)	<a href="http://www.national.com/sdi">www.national.com/sdi</a>		
Temperature Sensors	<a href="http://www.national.com/tempsensors">www.national.com/tempsensors</a>		
Wireless (PLL/VCO)	<a href="http://www.national.com/wireless">www.national.com/wireless</a>		

THE CONTENTS OF THIS DOCUMENT ARE PROVIDED IN CONNECTION WITH NATIONAL SEMICONDUCTOR CORPORATION ("NATIONAL") PRODUCTS. NATIONAL MAKES NO REPRESENTATIONS OR WARRANTIES WITH RESPECT TO THE ACCURACY OR COMPLETENESS OF THE CONTENTS OF THIS PUBLICATION AND RESERVES THE RIGHT TO MAKE CHANGES TO SPECIFICATIONS AND PRODUCT DESCRIPTIONS AT ANY TIME WITHOUT NOTICE. NO LICENSE, WHETHER EXPRESS, IMPLIED, ARISING BY ESTOPPEL OR OTHERWISE, TO ANY INTELLECTUAL PROPERTY RIGHTS IS GRANTED BY THIS DOCUMENT.

TESTING AND OTHER QUALITY CONTROLS ARE USED TO THE EXTENT NATIONAL DEEMS NECESSARY TO SUPPORT NATIONAL'S PRODUCT WARRANTY. EXCEPT WHERE MANDATED BY GOVERNMENT REQUIREMENTS, TESTING OF ALL PARAMETERS OF EACH PRODUCT IS NOT NECESSARILY PERFORMED. NATIONAL ASSUMES NO LIABILITY FOR APPLICATIONS ASSISTANCE OR BUYER PRODUCT DESIGN. BUYERS ARE RESPONSIBLE FOR THEIR PRODUCTS AND APPLICATIONS USING NATIONAL COMPONENTS. PRIOR TO USING OR DISTRIBUTING ANY PRODUCTS THAT INCLUDE NATIONAL COMPONENTS, BUYERS SHOULD PROVIDE ADEQUATE DESIGN, TESTING AND OPERATING SAFEGUARDS.

EXCEPT AS PROVIDED IN NATIONAL'S TERMS AND CONDITIONS OF SALE FOR SUCH PRODUCTS, NATIONAL ASSUMES NO LIABILITY WHATSOEVER, AND NATIONAL DISCLAIMS ANY EXPRESS OR IMPLIED WARRANTY RELATING TO THE SALE AND/OR USE OF NATIONAL PRODUCTS INCLUDING LIABILITY OR WARRANTIES RELATING TO FITNESS FOR A PARTICULAR PURPOSE, MERCHANTABILITY, OR INFRINGEMENT OF ANY PATENT, COPYRIGHT OR OTHER INTELLECTUAL PROPERTY RIGHT.

#### LIFE SUPPORT POLICY

**NATIONAL'S PRODUCTS ARE NOT AUTHORIZED FOR USE AS CRITICAL COMPONENTS IN LIFE SUPPORT DEVICES OR SYSTEMS WITHOUT THE EXPRESS PRIOR WRITTEN APPROVAL OF THE CHIEF EXECUTIVE OFFICER AND GENERAL COUNSEL OF NATIONAL SEMICONDUCTOR CORPORATION.** As used herein:

Life support devices or systems are devices which (a) are intended for surgical implant into the body, or (b) support or sustain life and whose failure to perform when properly used in accordance with instructions for use provided in the labeling can be reasonably expected to result in a significant injury to the user. A critical component is any component in a life support device or system whose failure to perform can be reasonably expected to cause the failure of the life support device or system or to affect its safety or effectiveness.

National Semiconductor and the National Semiconductor logo are registered trademarks of National Semiconductor Corporation. All other brand or product names may be trademarks or registered trademarks of their respective holders.

Copyright© 2008 National Semiconductor Corporation

For the most current product information visit us at [www.national.com](http://www.national.com)



**National Semiconductor  
Americas Technical  
Support Center**  
Email:  
[new.feedback@nsc.com](mailto:new.feedback@nsc.com)  
Tel: 1-800-272-9959

**National Semiconductor Europe  
Technical Support Center**  
Email: [europe.support@nsc.com](mailto:europe.support@nsc.com)  
German Tel: +49 (0) 180 5010 771  
English Tel: +44 (0) 870 850 4288

**National Semiconductor Asia  
Pacific Technical Support Center**  
Email: [ap.support@nsc.com](mailto:ap.support@nsc.com)

**National Semiconductor Japan  
Technical Support Center**  
Email: [jpn.feedback@nsc.com](mailto:jpn.feedback@nsc.com)