

# LM3401 Demo Board

National Semiconductor  
Application Note 1657  
Allan Fisher  
July 29, 2008



## Introduction

The LM3401 is a switching buck regulator derived current source designed to drive a series string of high power, high brightness LEDs. The LM3401 controls an external P-FET, allowing the user to select a power device for the desired level of forward LED current. The LM3401 demo board can supply continuous current as high as 1.0A from an input voltage range of 4.5V to 35V. It is designed to operate at ambient temperatures up to 75°C.

The LM3401 maintains constant current through any number of series-connected LEDs as long as the input voltage is greater than the combined forward voltage of the LED string. The LM3401 demo board includes an input terminal for a digital dimming signal, which is compatible with PWM dimming frequencies up to 10 kHz.

The complete demo board schematic is shown in *Figure 1*. Typical waveforms and performance curves for the LM3401 demo board are shown in *Figure 3* through *Figure 10*.

The standard Bill of Materials is shown in *Table 2*, with an additional Bill of Materials for a high current application shown

in *Table 4*. The pcb layout is shown in *Figure 11* and *Figure 12*.

## Powering Up

First, referring to *Table 1*, verify that the current setting resistor, R1, matches the desired LED current, and that the current limit resistor (R3) is set appropriately. The default values for R1 and R3 set the average LED current at 340 mA with a typical peak current limit threshold of 1.5A.

Next, connect the LED string to the terminals as shown in *Figure 2*. Connect the input voltage supply to the VIN and GND terminal posts. If dimming is being used, connect a digital PWM signal to the DIM post. When all connections and polarities are verified, power can be applied. LED strings should not be connected or disconnected from the output terminals while the demo board is powered up.

The LM3401 demo board can be easily modified to drive a variety of LEDs. Three current setting options are described in *Table 1*. For more detailed design and device information, refer to the LM3401 datasheet.

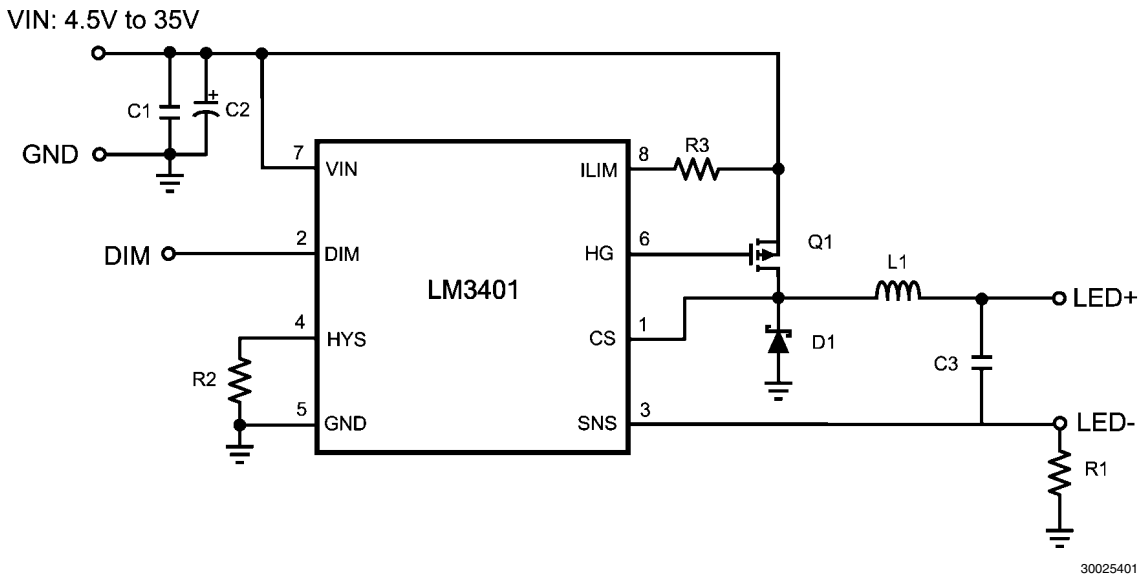

FIGURE 1. Complete LM3401 Demo Board Schematic

TABLE 1. LED current setting resistors (\* = default value)

LED average current	R1	R3 (typical current limit)	R1 power dissipation
340 mA *	0.59Ω*	24.9 kΩ (1.5A)*	68 mW
700 mA	0.29Ω	47 kΩ (2.8A)	142 mW
1.0A	0.20Ω	68 kΩ (3.9A)	200 mW

## Connecting the LED Array

The LM3401 demo board includes a female 6-pin SIP connector as well as two turret posts for the cathode and anode connections of the LED array. These are labeled "LED+" and "LED-". Either connection can be used. *Figure 2* shows the pinout of the SIP connector.

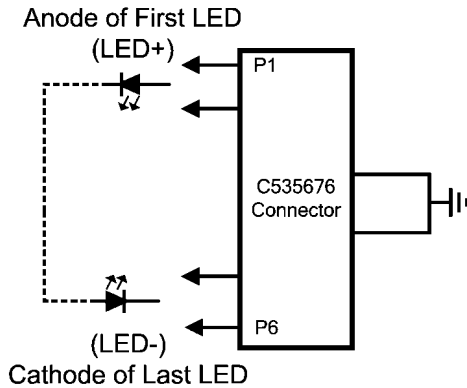

FIGURE 2. LED Connection

## Ripple Reduction Capacitor C3

The component C3 is optional and not installed on the standard demo board. This capacitor is used to reduce LED ripple current without changing average LED current or inductor current. Without C3, the LED ripple current is equal to the inductor ripple current. The peak-to-peak ripple current values shown in *Table 3* are without C3 installed. A typical C3 value of 1  $\mu\text{F}$  is recommended for most applications. Any type of low ESR capacitor can be used. However, the working

voltage must be rated higher than the maximum input voltage. C3 can also be used to reduce switching noise which could affect the SNS and DIM pins, especially at higher LED current. For noise reduction purposes, a C3 value of 220 pF is recommended.

## PWM Dimming

The DIM terminal on the PCB provides an input for a pulse width modulated (PWM) signal to control dimming of the LED string. The PWM signal should have a minimum logic high level of 2.25V, and minimum low and high periods of 100 ns. For the default demo board circuit, a dimming frequency less than 1kHz is recommended to maintain an adequate contrast ratio. The maximum contrast ratio is shown in *Figure 10*, and assumes a minimum of 2 switching cycles. The maximum contrast ratio depends largely on the rise time of the inductor current, and therefore is dependant on input voltage, inductor size, and LED string forward voltage. Additionally, if C3 is installed, the maximum contrast ratio or DIM frequency will be further reduced.

## Open Circuit/Short Circuit

If the LED array is disconnected or fails open, the LM3401 will operate at 100% duty cycle. The output voltage (at LED+) and CS node will rise to equal the input voltage; the circuit is rated to 40V and will not suffer damage. However, care should be taken not to connect an LED string when the demo board is powered up and the output is high as excessive surge current may damage the LEDs.

The default current limit threshold is typically 1.5A, set by R3. The current limit will protect the circuit from a short at the LED anode or cathode. Current limit is sensed across the  $R_{\text{DSon}}$  of the PFET and will therefore vary with temperature. R3 can be adjusted if a different current limit threshold is required. Refer to the LM3401 datasheet for current limit details.

TABLE 2. Bill of Materials

Ref. #	Description	Part Number	Size	Vendor
IC1	LED Controller	LM3401	MSOP-8	NSC
L1	68 $\mu\text{H}$ , 1.7A, Inductor	MSS1260T-683ML	12x12	Coilcraft
Q1	40V, 1.8A, 100 m $\Omega$ , PFET	Si2319DS	SOT-23	Vishay
D1	40V, 2A, Schottky	SSA24	SMA	Vishay
C1	50V, 2.2 $\mu\text{F}$ , ceramic	C3225X5R1H225K	1210	TDK
C2	50V, 33 $\mu\text{F}$ , electrolytic	EEEHA1H330XP	6.6 x 6.6	Panasonic
C3*	Not installed	-	1206	-
R1	0.59 $\Omega$ , 1%, 1/4W	SR732BLTER590F	1206	KOA
R2	5.76 k $\Omega$ , 1%	CRCW08055761F	0805	Vishay
R3	24.9 k $\Omega$ 1%	CRCW08052492F	0805	Vishay

# Typical Performance Characteristics

Unless otherwise specified, the following conditions apply:  $V_{in} = 24V$ ,  $T_a = 25^\circ C$ , LED = 2 x Osram Golden Dragon ( $V_f = 3.4V$ ,  $I_f = 350\text{ mA}$ )

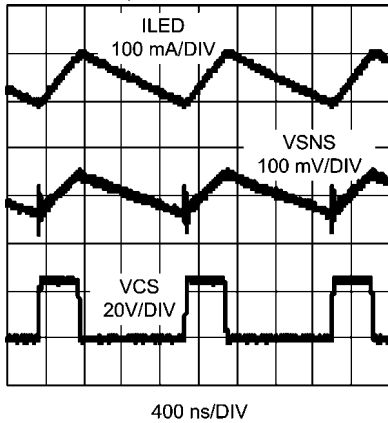

30025403

FIGURE 3. CS, SNS, and LED Current Waveforms

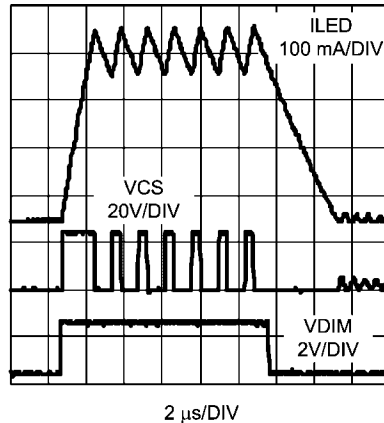

30025406

FIGURE 6. Dimming Waveforms

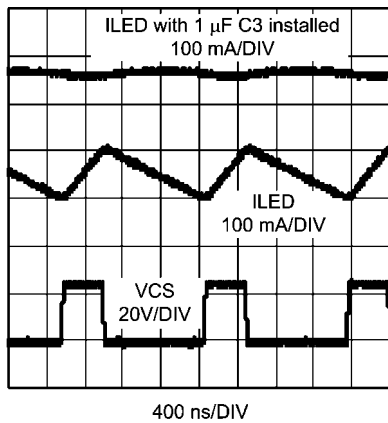

30025404

FIGURE 4. ILED with and without C3

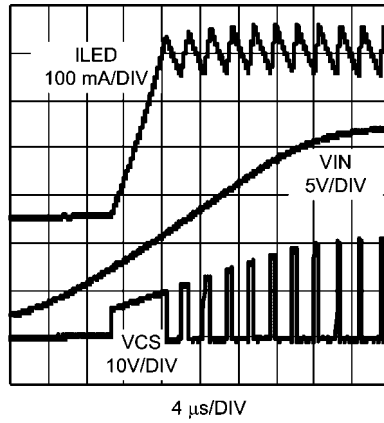

30025407

FIGURE 7. Startup Waveforms

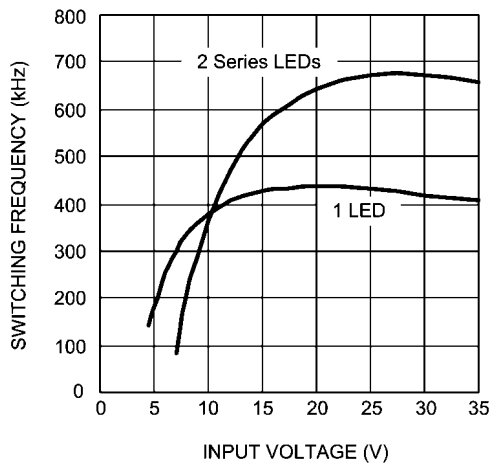

30025405

FIGURE 5. Switching Frequency vs VIN

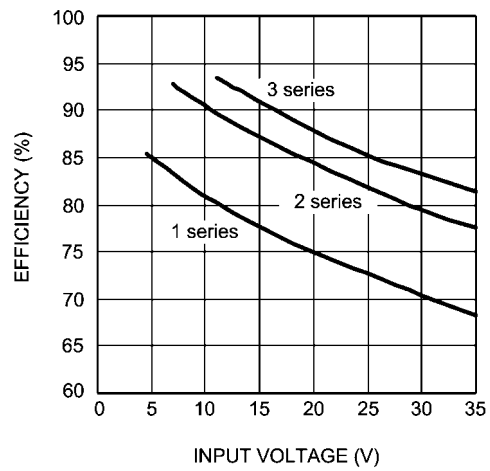

30025408

FIGURE 8. Efficiency vs Input Voltage Driving 350 mA LEDs

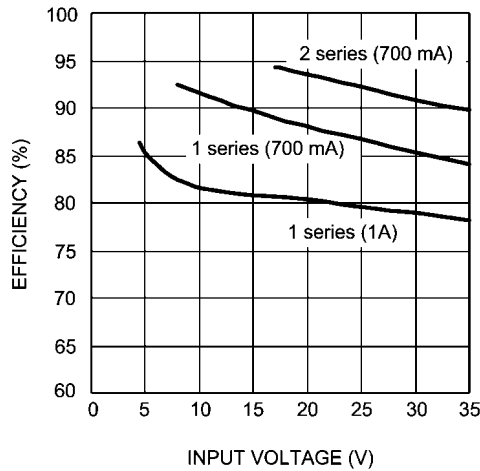

30025409

**FIGURE 9. Efficiency vs Input Voltage  
Driving 700 mA and 1A LEDs**

## LED String Options

The default LED current setting is 340 mA, typical of many 1W LEDs. To adjust this value, the current setting resistor, R1, can be changed according to *Table 1*. For other values, use the equation below:

$$R1 = \frac{200 \text{ mV}}{I_{LED}}$$

R1 must be rated to handle the power dissipation of the LED current. For example, in steady state R1 will dissipate  $(0.340^2 \times 0.59) = 68 \text{ mW}$ , indicating that a resistor with a 1/8W power rating would be appropriate.

**TABLE 3. Typical Operating Conditions (\* = at 24Vin)**

# of series LEDs	LED Type	Average LED current	* Freq.	* p-p ripple	Minimum VIN
1	Osram golden dragon	340 mA	425 kHz	110 mA	4.5V
2	Osram golden dragon	340 mA	655 kHz	110 mA	7.0V
3	Luxeon Star	340 mA	800 kHz	110 mA	10.4V
4	Luxeon Star	340 mA	845 kHz	110 mA	13.8V
1	Luxeon V Star	700 mA	415 kHz	190 mA	7.0V
2	Luxeon V Star	700 mA	500 kHz	190 mA	14.5V
1	Luxeon K2 Emitter	1A	230 kHz	280 mA	4.5V

The LM3401 can also drive LED currents in excess of 1A. For these applications a larger pad is provided for a higher current PFET. An example BOM for a typical 3.5A application is shown in *Table 4*. The switching frequency, ripple current, and current limit values will depend on the number and type of

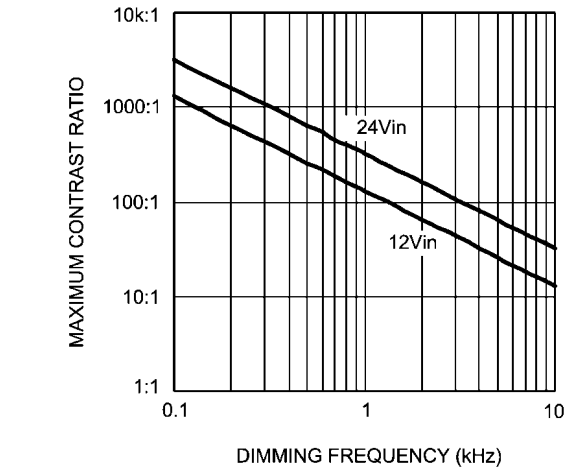

30025410

**FIGURE 10. Maximum Contrast Ratio vs  
Dimming Frequency (100:1 = 1% duty)**

The LM3401 demo board can drive a wide variety of LEDs. Ripple current and switching frequency will vary with the LED forward voltage, number of LEDs, and input voltage. *Table 3* shows the typical results for some common LED strings when using the *Table 1* settings at an input voltage of 24V. Typical switching frequency vs input voltage is shown in *Figure 5*.

For some LED strings, the demo board settings given in *Table 1* may not be appropriate. For example, where the switching frequency increases above the 1.5 MHz maximum or where LED ripple current is higher than the maximum LED rating. In this case, refer to the LM3401 datasheet to modify the demo board as needed.

LEDs installed, as well as the selected PFET. A low  $V_{gs}$  threshold PFET is recommended for higher current applications, as the initial HG voltage will decrease somewhat when driving PFETs with a larger gate capacitance. Refer to the LM3401 datasheet for detailed design information.

TABLE 4. BOM for 3.5A Application ( $V_{in} = 5V$  to  $20V$ )

Ref. #	Description	Part Number	Size	Vendor
IC1	LED Controller	LM3401	MSOP-8	NSC
L1	5.2 $\mu$ H, 5A, Inductor	MSS1038-522NL	10.2 x 10.4	Coilcraft
Q1	20V, 4A, 25 m $\Omega$ , PFET	Si3493BDV	SO-6	Vishay
D1	30V, 4A, Schottky	SSB43L	SMB	Vishay
C1	25V, 10 $\mu$ F, ceramic	C3225X5R1E106K	1210	TDK
C2	50V, 33 $\mu$ F, electrolytic	EEEHA1H330XP	6.6 x 6.6	Panasonic
C3	25V, 220 pF, ceramic	-	0805	-
R1	0.0576 $\Omega$ , 1%, 1W	WSL2512R0576F	2512	Vishay
R2	4.7 k $\Omega$ , 1%	-	0805	-
R3	40 k $\Omega$ , 1%	-	0805	-

## PCB Layout

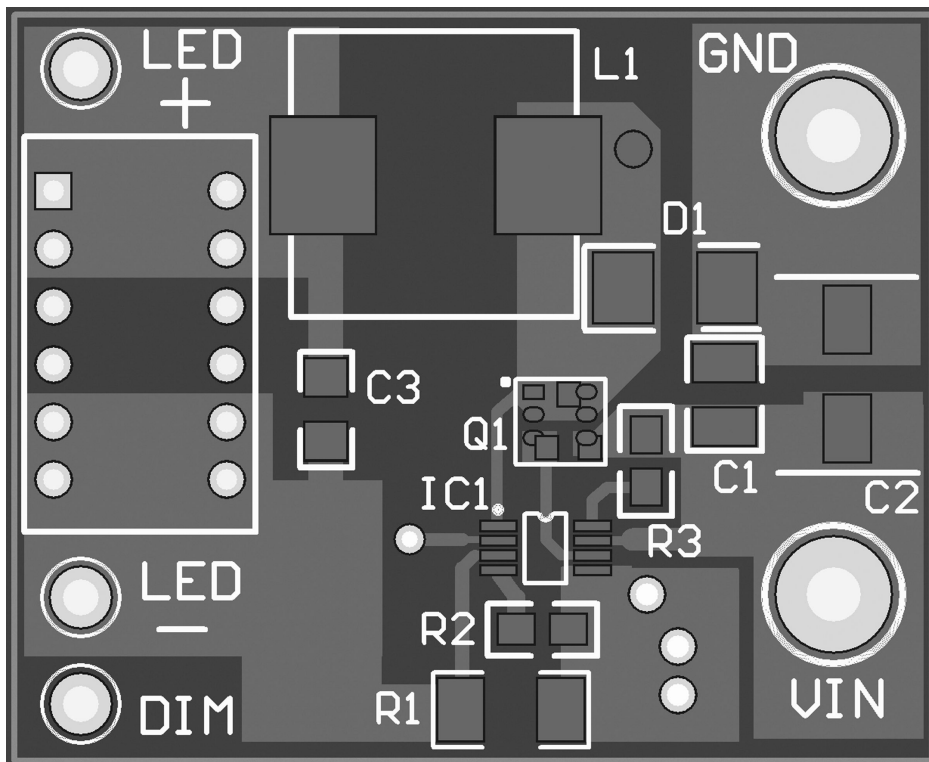

30025411

FIGURE 11. Top Side PCB Layout

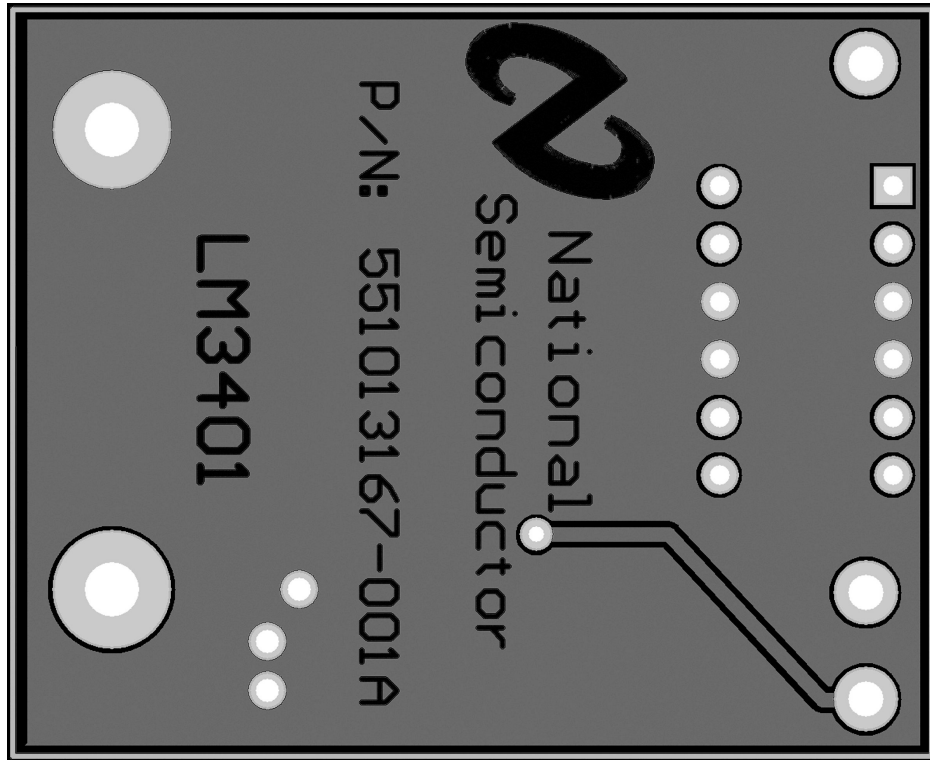

30025412

FIGURE 12. Bottom Side PCB Layout

# Notes

AN-1657

# Notes

For more National Semiconductor product information and proven design tools, visit the following Web sites at:

Products		Design Support	
Amplifiers	<a href="http://www.national.com/amplifiers">www.national.com/amplifiers</a>	WEBENCH	<a href="http://www.national.com/webench">www.national.com/webench</a>
Audio	<a href="http://www.national.com/audio">www.national.com/audio</a>	Analog University	<a href="http://www.national.com/AU">www.national.com/AU</a>
Clock Conditioners	<a href="http://www.national.com/timing">www.national.com/timing</a>	App Notes	<a href="http://www.national.com/appnotes">www.national.com/appnotes</a>
Data Converters	<a href="http://www.national.com/adc">www.national.com/adc</a>	Distributors	<a href="http://www.national.com/contacts">www.national.com/contacts</a>
Displays	<a href="http://www.national.com/displays">www.national.com/displays</a>	Green Compliance	<a href="http://www.national.com/quality/green">www.national.com/quality/green</a>
Ethernet	<a href="http://www.national.com/ethernet">www.national.com/ethernet</a>	Packaging	<a href="http://www.national.com/packaging">www.national.com/packaging</a>
Interface	<a href="http://www.national.com/interface">www.national.com/interface</a>	Quality and Reliability	<a href="http://www.national.com/quality">www.national.com/quality</a>
LVDS	<a href="http://www.national.com/lvds">www.national.com/lvds</a>	Reference Designs	<a href="http://www.national.com/refdesigns">www.national.com/refdesigns</a>
Power Management	<a href="http://www.national.com/power">www.national.com/power</a>	Feedback	<a href="http://www.national.com/feedback">www.national.com/feedback</a>
Switching Regulators	<a href="http://www.national.com/switchers">www.national.com/switchers</a>		
LDOs	<a href="http://www.national.com/lido">www.national.com/lido</a>		
LED Lighting	<a href="http://www.national.com/led">www.national.com/led</a>		
PowerWise	<a href="http://www.national.com/powerwise">www.national.com/powerwise</a>		
Serial Digital Interface (SDI)	<a href="http://www.national.com/sdi">www.national.com/sdi</a>		
Temperature Sensors	<a href="http://www.national.com/tempsensors">www.national.com/tempsensors</a>		
Wireless (PLL/VCO)	<a href="http://www.national.com/wireless">www.national.com/wireless</a>		

THE CONTENTS OF THIS DOCUMENT ARE PROVIDED IN CONNECTION WITH NATIONAL SEMICONDUCTOR CORPORATION ("NATIONAL") PRODUCTS. NATIONAL MAKES NO REPRESENTATIONS OR WARRANTIES WITH RESPECT TO THE ACCURACY OR COMPLETENESS OF THE CONTENTS OF THIS PUBLICATION AND RESERVES THE RIGHT TO MAKE CHANGES TO SPECIFICATIONS AND PRODUCT DESCRIPTIONS AT ANY TIME WITHOUT NOTICE. NO LICENSE, WHETHER EXPRESS, IMPLIED, ARISING BY ESTOPPEL OR OTHERWISE, TO ANY INTELLECTUAL PROPERTY RIGHTS IS GRANTED BY THIS DOCUMENT.

TESTING AND OTHER QUALITY CONTROLS ARE USED TO THE EXTENT NATIONAL DEEMS NECESSARY TO SUPPORT NATIONAL'S PRODUCT WARRANTY. EXCEPT WHERE MANDATED BY GOVERNMENT REQUIREMENTS, TESTING OF ALL PARAMETERS OF EACH PRODUCT IS NOT NECESSARILY PERFORMED. NATIONAL ASSUMES NO LIABILITY FOR APPLICATIONS ASSISTANCE OR BUYER PRODUCT DESIGN. BUYERS ARE RESPONSIBLE FOR THEIR PRODUCTS AND APPLICATIONS USING NATIONAL COMPONENTS. PRIOR TO USING OR DISTRIBUTING ANY PRODUCTS THAT INCLUDE NATIONAL COMPONENTS, BUYERS SHOULD PROVIDE ADEQUATE DESIGN, TESTING AND OPERATING SAFEGUARDS.

EXCEPT AS PROVIDED IN NATIONAL'S TERMS AND CONDITIONS OF SALE FOR SUCH PRODUCTS, NATIONAL ASSUMES NO LIABILITY WHATSOEVER, AND NATIONAL DISCLAIMS ANY EXPRESS OR IMPLIED WARRANTY RELATING TO THE SALE AND/OR USE OF NATIONAL PRODUCTS INCLUDING LIABILITY OR WARRANTIES RELATING TO FITNESS FOR A PARTICULAR PURPOSE, MERCHANTABILITY, OR INFRINGEMENT OF ANY PATENT, COPYRIGHT OR OTHER INTELLECTUAL PROPERTY RIGHT.

## LIFE SUPPORT POLICY

**NATIONAL'S PRODUCTS ARE NOT AUTHORIZED FOR USE AS CRITICAL COMPONENTS IN LIFE SUPPORT DEVICES OR SYSTEMS WITHOUT THE EXPRESS PRIOR WRITTEN APPROVAL OF THE CHIEF EXECUTIVE OFFICER AND GENERAL COUNSEL OF NATIONAL SEMICONDUCTOR CORPORATION.** As used herein:

Life support devices or systems are devices which (a) are intended for surgical implant into the body, or (b) support or sustain life and whose failure to perform when properly used in accordance with instructions for use provided in the labeling can be reasonably expected to result in a significant injury to the user. A critical component is any component in a life support device or system whose failure to perform can be reasonably expected to cause the failure of the life support device or system or to affect its safety or effectiveness.

National Semiconductor and the National Semiconductor logo are registered trademarks of National Semiconductor Corporation. All other brand or product names may be trademarks or registered trademarks of their respective holders.

Copyright© 2008 National Semiconductor Corporation

For the most current product information visit us at [www.national.com](http://www.national.com)



**National Semiconductor Americas Technical Support Center**  
Email: [support@nsc.com](mailto:support@nsc.com)  
Tel: 1-800-272-9959

**National Semiconductor Europe Technical Support Center**  
Email: [europe.support@nsc.com](mailto:europe.support@nsc.com)  
German Tel: +49 (0) 180 5010 771  
English Tel: +44 (0) 870 850 4288

**National Semiconductor Asia Pacific Technical Support Center**  
Email: [ap.support@nsc.com](mailto:ap.support@nsc.com)

**National Semiconductor Japan Technical Support Center**  
Email: [jpn.feedback@nsc.com](mailto:jpn.feedback@nsc.com)