

LM3433 10A to 40A LED Driver Evaluation Board

National Semiconductor
Application Note 1937
Clinton Jensen
January 14, 2010



Introduction

The LM3433 is an adaptive constant on-time DC/DC buck constant current controller designed to drive a high brightness LED (HB LED) at high forward currents. It is a true current source that provides a constant current with constant ripple current regardless of the LED forward voltage drop. The board can accept an input voltage ranging from -9V to -14V w.r.t. GND. The output configuration allows the anodes of multiple LEDs to be tied directly to the ground referenced chassis for maximum heat sink efficacy when a negative input voltage is used.

LM3433 High Current Board Description

The evaluation board is designed to provide a constant current in the range of 10A to 60A (although the board is thermally limited to approximately 40A continuous operation) and can connect directly to a Luminus Devices, Inc. PhlatLight® PT-120 or similar high current LED. It is ideal for pulsing an LED at 30A or greater for applications such as rear and forward projection. The LM3433 requires two input voltages for operation. A positive voltage with respect to GND is required for the bias and control circuitry and a negative voltage with respect to GND is required for the main power input. This allows for the capability of using common anode LEDs so that the anodes can be tied to the ground referenced chassis. The evaluation board only requires one input voltage of -12V with respect to GND (any high current 12V supply will work). The positive voltage w.r.t. GND on the board is supplied by the LM5002 circuit (see below). Initially the output current is set at the minimum of approximately 10A with the POT P1 fully counter-clockwise. To set the desired current level a short may be connected between LED+ and LED-, then use a current probe and turn the POT clockwise until the desired current is reached. PWM dimming FETs are included on-board for testing when the LED can be connected directly next to the board. A shutdown test post on J2, ENA, is included so that startup and shutdown functions can be tested using an external voltage. Note that the test points for GND and -12V are for measurement only, the high current input source should be connected through J1.

LM5002 Circuit

The positive voltage w.r.t. GND on the board is supplied by the LM5002 circuit. The LM5002 feedback is level shifted so that the output that supplies the LM3433 bias circuitry will remain at +5V w.r.t. GND regardless of where VEE is in the -9V to -14V range. The LM5002 circuit also provides a UVLO function to remove the possibility of the LM3433 drawing high currents at input voltages less than -9V during startup. This circuit was designed with enough output current to power a small 5V sideblower fan (Sunon part number B0502AFB2-8) to help keep the inductor, and therefore the board to some degree, cooler if extreme ambient temperatures are expected. One LM5002 circuit can supply enough current to drive

the positive voltage for multiple LM3433 circuits in a system, up to approximately 100.

Setting the LED Current

The LM3433 evaluation board is designed so that the LED current can be set in multiple ways. There is a shunt on J2 initially connecting the ADJ pin to the POT allowing the current to be adjusted using the POT P1. This POT will apply a voltage to the ADJ pin between 0.3V and 1.5V w.r.t. GND to adjust the voltage across the sense resistor (R_{SENSE}) R15. The shunt may also be removed and an external voltage positive w.r.t. GND can then be applied to the ADJ test point on the board. A 2m Ω resistor comes mounted on the board (five 10m Ω resistors in parallel) so using the V_{SENSE} vs. V_{ADJ} graph in the *Typical Performance Characteristics* section the current can be set using the following equation:

$$I_{LED} = V_{SENSE} / R_{SENSE}$$

Alternatively the shunt can be removed and the ADJ test point can be connected to the VINX test point to fix V_{SENSE} at 60mV for 30A output current.

PWM Dimming

The LM3433 is capable of high speed PWM dimming in excess of 40kHz. Dimming is accomplished by shorting across the LED with a FET(s). Dimming FETs are included on the evaluation board for testing LEDs placed close to the board. The FETs on the evaluation board should be removed if using dimming FETs remotely placed close to the LED (STRONGLY recommended). If the FETs cannot be placed directly next to the LED then some form of snubber may be required to prevent damage to the LM3433, LM5111, and LM2937 due to the large spikes caused by inductance between the LED and FETs. D4, C17, and R32 may be used to populate a snubber circuit.

To use the dimming function apply square wave to the PWM test point on the board that has a positive voltage w.r.t. GND. When this pin is pulled high the dimming FET is enabled and the LED turns off. When it is pulled low the dimming FET is turned off and the LED turns on. A scope plot of PWM dimming is included in the *Typical Performance Characteristics* section showing 120Hz dimming at 20% duty cycle.

Reducing Component Count

This board has been optimized to reduce losses in the power FETs and dimming FETs by using the LM5111 gate drivers to increase the gate drive current as well as the gate voltage for minimum $R_{DS(ON)}$. If more power dissipation and/or lower efficiency can be tolerated when PWM dimming then some components may be removed. As shipped an LM5111 is used to drive the PWM FET gates. The LM5111 is powered by using D6 and C25 to form a charge pump to generate a positive voltage above GND that is approximately equal to $|VEE|$. This voltage is then regulated down to 12V above LED- with the LM2937 to power the LM5111. The result is high gate drive current capability and a high gate voltage for the dimming FETs. With the use of the LM5111s on the main power FETs

PhlatLight® is a registered trademark of Luminus Devices, Inc.

the LM3433 has enough internal drive current capability to drive the dimming FETs without the use of external components. The $R_{DS(ON)}$ will increase and the switch transitions will be slower but all related components could be removed. In this case R14 should be loaded and the following components may be removed: U5, U6, R33, D6, C22, and C25.

Alternatively if a high voltage gate driver is used ($VCC = |V_{EE}| + V_f$ where V_f is the LED forward voltage drop) then D5 and C23 may be added to power the gate driver IC directly with the charge pump and U6, D6, and C25 may be removed.

High Current Operation and Component Lifetime

When driving high current LEDs, particularly when PWM dimming, component lifetime may become a factor. In these cases the input ripple current that the input capacitors are required to withstand can become large. At lower currents long life ceramic capacitors may be able to handle this ripple current without a problem. At higher currents more input capacitance may be required. To remain cost effective this may require putting one or more aluminum electrolytic capacitors in parallel with the ceramic input capacitors. Since the operational lifetime of LEDs is very long (up to 50,000 hours) the longevity of an aluminum electrolytic capacitor can become the main factor in the overall system lifetime. The first consideration for selecting the input capacitors is the RMS ripple current they will be required to handle. This current is given by the following equation:

$$I_{RMS} = I_{LED} \frac{\sqrt{V_{LED}(|V_{EE}| - V_{LED})}}{|V_{EE}|}$$

The parallel combination of the ceramic and aluminum electrolytic input capacitors must be able to handle this ripple current. The aluminum electrolytic in particular should be able

to handle the ripple current without a significant rise in core temperature. A good rule of thumb is that if the case temperature of the capacitor is 5°C above the ambient board temperature then the capacitor is not capable of sustaining the ripple current for its full rated lifetime and a more robust or lower ESR capacitor should be selected.

The other main considerations for aluminum electrolytic capacitor lifetime are the rated lifetime and the ambient operating temperature. An aluminum electrolytic capacitor comes with a lifetime rating at a given core temperature, such as 5000 hours at 105°C. As dictated by physics the capacitor lifetime should double for each 7°C below this temperature the capacitor operates at and should halve for each 7°C above this temperature the capacitor operates at. A good quality aluminum electrolytic capacitor will also have a core temperature of approximately 3°C to 5°C above the ambient temperature at rated RMS operating current. So as an example, a capacitor rated for 5,000 hours at 105°C that is operating in an ambient environment of 85°C will have a core temperature of approximately 90°C at full rated RMS operating current. In this case the expected operating lifetime of the capacitor will be approximately just over 20,000 hours. The actual lifetime ($Life_{ACTUAL}$) can be found using the equation:

$$Life_{ACTUAL} = Life_{RATED} \times 2^{\left(\frac{T_{CORE} - T_{ACTUAL}}{7}\right)}$$

Where $Life_{RATED}$ is the rated lifetime at the rated core temperature T_{CORE} . For example: If the ambient temperature is 85°C the core temperature is 85°C + 5°C = 90°C. $(105°C - 90°C)/7°C = 2.143$. $2^{2.143} = 4.417$. So the expected lifetime is $5,000 \times 4.417 = 22,085$ hours. Long life capacitors are recommended for LED applications and are available with ratings of up to 20,000 hours or more at 105°C.

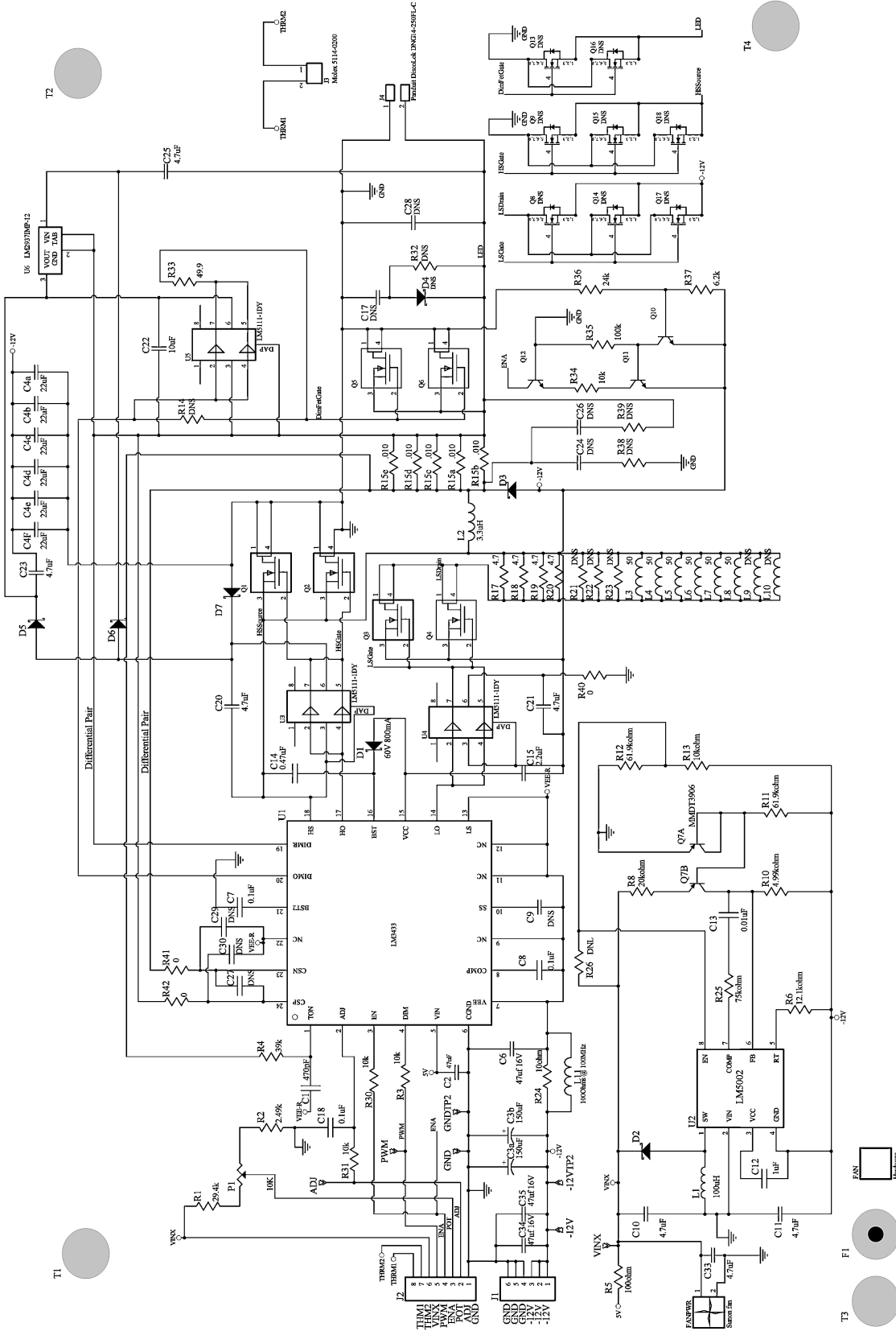

FIGURE 1. LM3433 Evaluation Board Schematic

TABLE 1. BOM

ID	Part Number	Type	Size	Parameters	Qty	Vendor
U1	LM3433	LED Driver	LLP-24		1	NSC
U2	LM5002MA	Boost Regulator	SO-8		1	NSC
U3, U4, U5	LM5111-1MY	Gate Driver	eMSOP-8		3	NSC
U6	LM2937IMP-12	Linear Regulator	SOT-223		1	NSC
C1	C0805C471K5RACTU	Capacitor	0805	470pF, 50V	1	Kemet
C2	LMK316BJ476ML-T	Capacitor	1206	47μF, 6.3V	1	Taiyo Yuden
C3a, C3b	16SH150M	Capacitor	MULTICAP	150μF, 16V	2	Sanyo
C4a, C4b, C4c, C4d, C4e, C4f	GRM32ER61C226KE20L	Capacitor	1210	22μF, 16V	6	Murata
C6, C34, C35	GRM32ER61C476ME15L	Capacitor	1210	47μF, 16V	3	Murata
C7, C8, C18	C0805C104J5RACTU	Capacitor	0805	0.1μF, 50V	3	Kemet
C9, C17, C23, C24, C26, C27, C29, C30	OPEN		0805			
C10, C11, C20, C21, C25, C33	GRM21BR61C475KA	Capacitor	0805	4.7μF, 16V	6	Murata
C12	0805YD105KAT2A	Capacitor	0805	1μF, 16V	1	AVX
C13	C0805C103K1RACTU	Capacitor	0805	10nF, 100V	1	Kemet
C14	B37941K9474K60	Capacitor	0805	0.47μF, 16V	1	EPCOS Inc .
C15	GRM21BF51E225ZA01L	Capacitor	0805	2.2μF, 25V	1	Murata
C22	GRM21BR61C106KE15	Capacitor	0805	10μF, 25V	1	Murata
C18	08055C104JAT2A	Capacitor	0805	0.1μF, 50V	1	AVX
C28	OPEN		1210			
D1, D2, D6, D7	MA2YD2600L	Diode	SOD-123	60V, 800mA	2	Panasonic
D3	MBRS240LT3	Diode	SMB	40V, 2A	1	ON Semiconductor
D4	OPEN		SMB			
D5	OPEN		SOD-123			
J2	B8B-EH-A(LF)(SN)	Connector			1	JST Sales America, Inc.
J1	1761582001	Connector			1	Weidmuller
J1*	1610180000	Connector Plug			1	Weidmuller
J3	Molex 5114-0200	Connector	Molex thermistor 1.25mm 2pos		1	Molex
J4	Keystone 3547	Connector	Female quick- disconnect terminal pair		2	Keystone
L1	LPS3015-124ML	Inductor	3015	120μH, 220mA	1	Coilcraft
L2	SER2915L-332KL	Inductor	SER2900	3.3μH, 48A	1	Coilcraft
L3, L4, L5, L6, L7, L8	HI1206T500R-10	Ferrite Bead	1206	50Ω @ 100MHz	6	Steward
L9, L10	OPEN		1206			
L11	MPZ2012S101A	Ferrite Bead	0805	100Ω @ 100MHz	1	TDK
P1	3352T-1-103LF	Potentiometer	BOURNS2	10kΩ	1	Bourns
Q1, Q2, Q3, Q4, Q5, Q6	SIE808DF-T1-E3	FET	PolarPAK	20V, 1.5mΩ	6	Vishay
Q7	MMDT3906 -7	Dual PNP	SOT363_N		1	Diodes Inc.

ID	Part Number	Type	Size	Parameters	Qty	Vendor
Q8, Q9, Q13, Q14, Q15, Q16, Q17, Q18	OPEN		SOIC-8			
Q10, Q11, Q12	MMBT3904 -7	NPN	SOT-23		3	Diodes Inc.
R1	ERJ-6ENF2942V	Resistor	0805	29.4k Ω	1	Panasonic
R2	ERJ-6ENF2491V	Resistor	0805	2.49k Ω	1	Panasonic
R3, R13, R30, R31	ERJ-6ENF1002V	Resistor	0805	10k Ω	4	Panasonic
R4	ERJ-6GEYJ393V	Resistor	0805	39k Ω	1	Panasonic
R5	ERJ-6GEYJ101V	Resistor	0805	100 Ω	1	Panasonic
R6	ERJ-6ENF1212V	Resistor	0805	12.1k Ω	1	Panasonic
R8	ERJ-6ENF2002V	Resistor	0805	20k Ω	1	Panasonic
R10	ERJ-6ENF4991V	Resistor	0805	4.99k Ω	1	Panasonic
R11, R12	ERJ-6ENF6192V	Resistor	0805	61.9k Ω	2	Panasonic
R15a, R15b, R15c, R15d, R15e	WSL2512R0100FEA	Resistor	2512	0.01 Ω	5	Vishay
R17, R18, R19, R20	ERJ-8RQF4R7V	Resistor	1206	4.7 Ω	4	Panasonic
R24	ERJ-6GEYJ100V	Resistor	0805	10 Ω	1	Panasonic
R25	ERJ-6ENF7502V	Resistor	0805	75k Ω	1	Panasonic
R33	ERJ-6ENF49R9V	Resistor	1206	49.9 Ω	1	Panasonic
R34	ERJ-6GEYJ103V	Resistor	1206	10k Ω	1	Panasonic
R35	CRCW0805100KFKEA	Resistor	1206	100k Ω	1	Vishay
R36	CRCW080524K0FKEA	Resistor	1206	24k Ω	1	Vishay
R37	CRCW08056K20FKEA	Resistor	1206	6.2k Ω	1	Vishay
R14, R21, R22, R23, R32, R38, R39	OPEN		0805			
R40, R41, R42	ERJ-6GEY0R00V	Resistor	0805	0 Ω	3	Panasonic
-12V, GND	1502-2	Test Post	TP 1502	0.109"	2	Keystone
ADJ, PWM, VINX	1593-2	Test Post	TP 1593	0.084"	3	Keystone

Typical Performance Characteristics

Efficiency vs. V_{EE} Voltage
 ($I_{LED} = 18A, V_{LED} = 4.3V$)

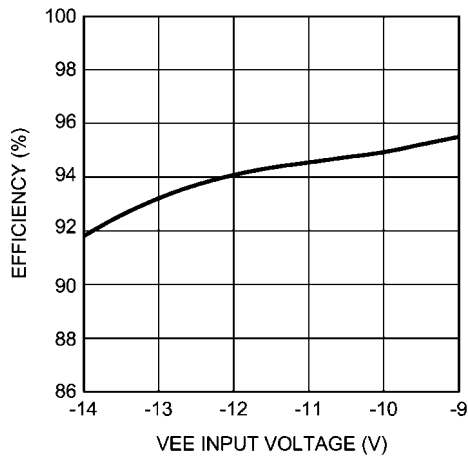

30089405

V_{SENSE} vs. V_{ADJ}

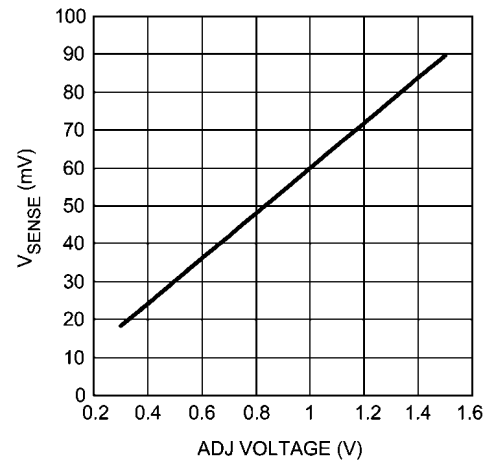

30089408

120Hz PWM Dimming Waveform

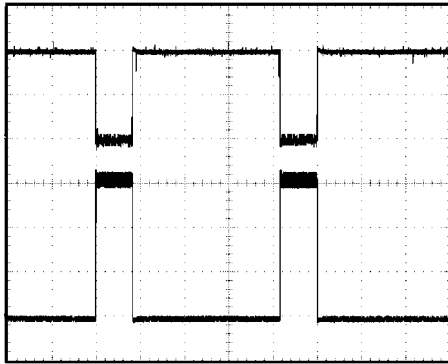

30089409

$I_{LED} = 30A$ nominal, $V_{IN} = 5V, V_{EE} = -12V$

Top trace: DIM input, 1V/div, DC

Bottom trace: I_{LED} , 10A/div, DC

T = 2ms/div

Layout

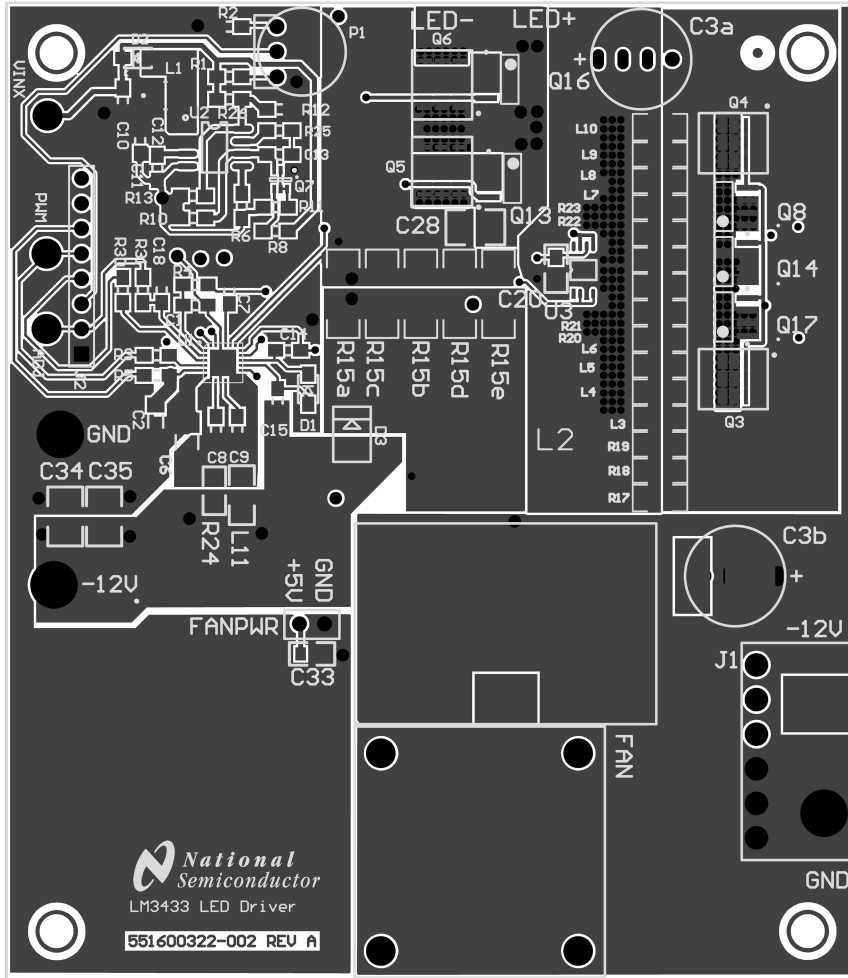

Top Layer and Top Overlay

30089420

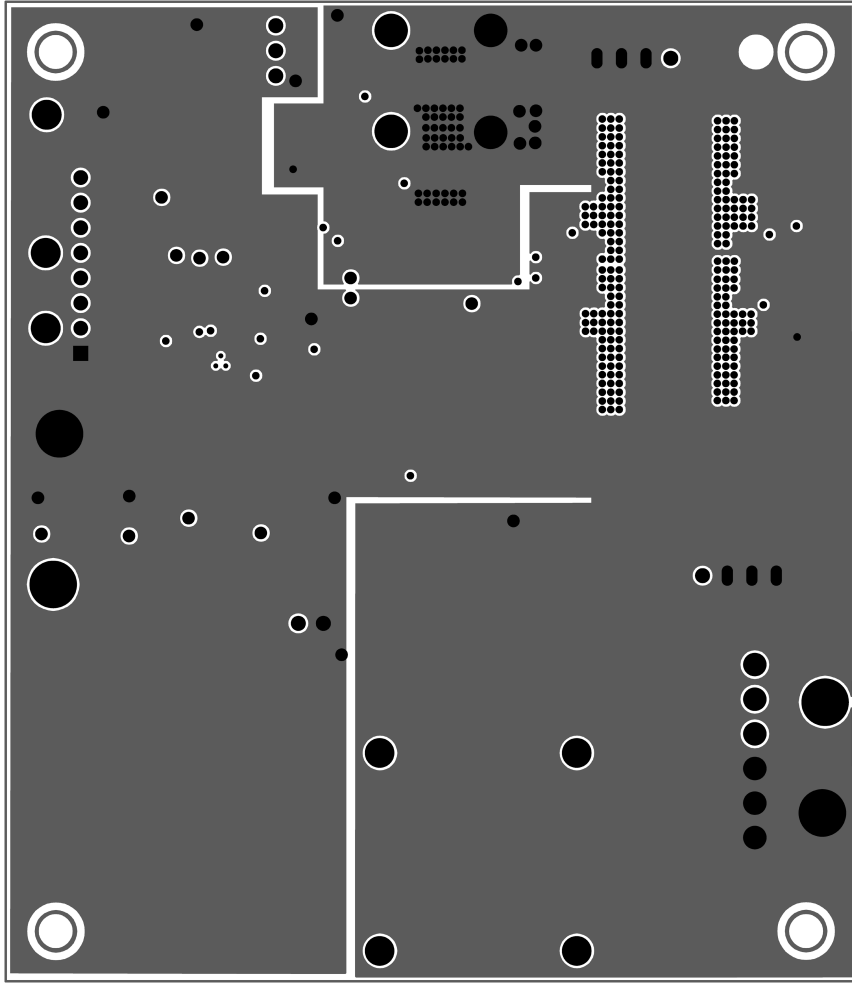

Upper Middle Layer

30089421

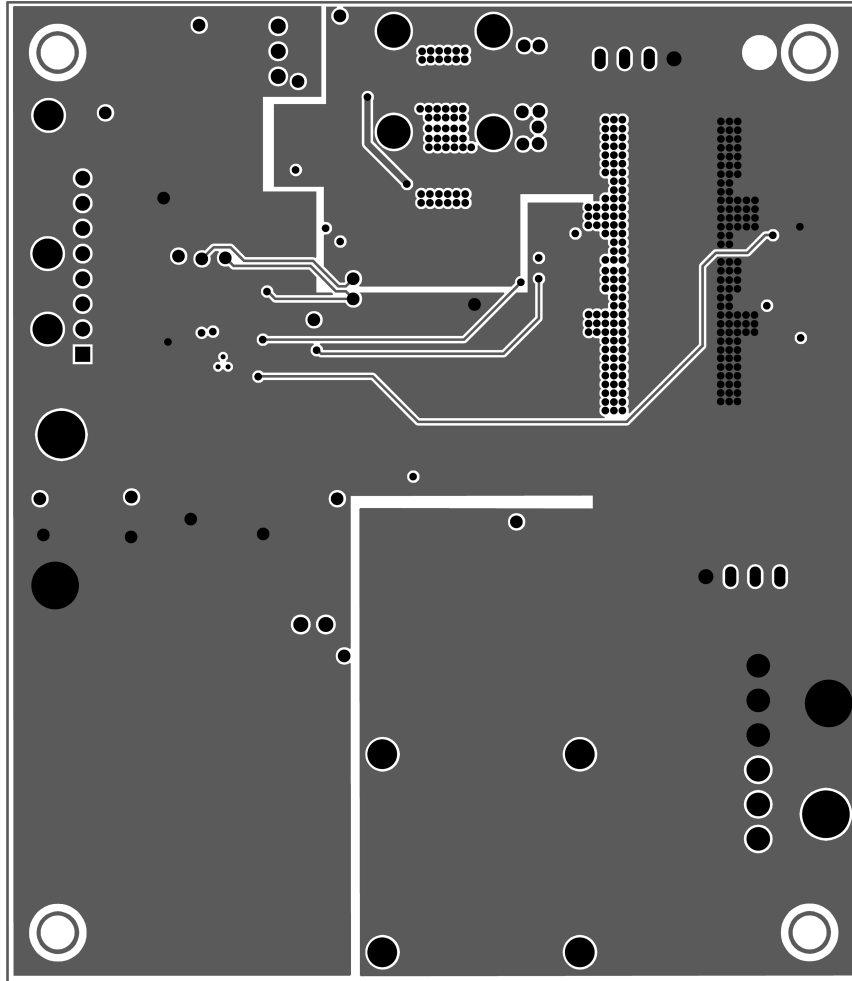

Lower Middle Layer

30089422

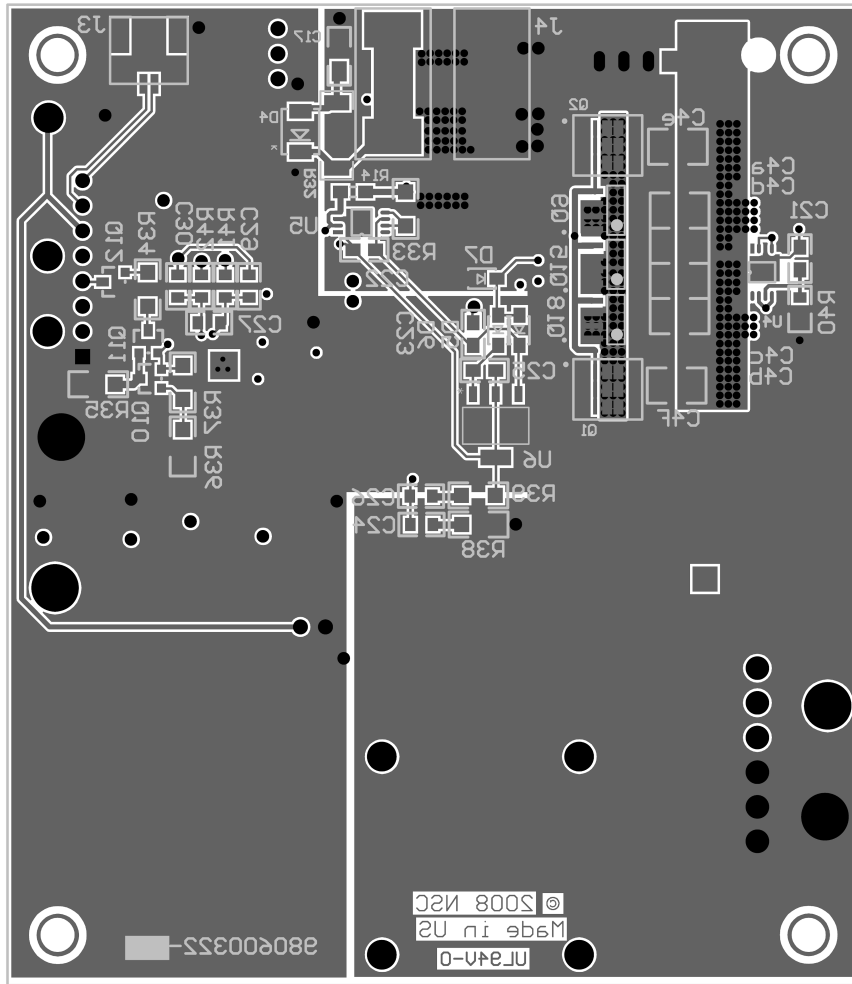

Bottom Layer and Bottom Overlay

30089423

Notes

AN-1937

Notes

For more National Semiconductor product information and proven design tools, visit the following Web sites at:
www.national.com

Products		Design Support	
Amplifiers	www.national.com/amplifiers	WEBENCH® Tools	www.national.com/webench
Audio	www.national.com/audio	App Notes	www.national.com/appnotes
Clock and Timing	www.national.com/timing	Reference Designs	www.national.com/refdesigns
Data Converters	www.national.com/adc	Samples	www.national.com/samples
Interface	www.national.com/interface	Eval Boards	www.national.com/evalboards
LVDS	www.national.com/lvds	Packaging	www.national.com/packaging
Power Management	www.national.com/power	Green Compliance	www.national.com/quality/green
Switching Regulators	www.national.com/switchers	Distributors	www.national.com/contacts
LDOs	www.national.com/lido	Quality and Reliability	www.national.com/quality
LED Lighting	www.national.com/led	Feedback/Support	www.national.com/feedback
Voltage References	www.national.com/vref	Design Made Easy	www.national.com/easy
PowerWise® Solutions	www.national.com/powerwise	Applications & Markets	www.national.com/solutions
Serial Digital Interface (SDI)	www.national.com/sdi	Mil/Aero	www.national.com/milaero
Temperature Sensors	www.national.com/tempensors	SolarMagic™	www.national.com/solarmagic
PLL/VCO	www.national.com/wireless	PowerWise® Design University	www.national.com/training

THE CONTENTS OF THIS DOCUMENT ARE PROVIDED IN CONNECTION WITH NATIONAL SEMICONDUCTOR CORPORATION ("NATIONAL") PRODUCTS. NATIONAL MAKES NO REPRESENTATIONS OR WARRANTIES WITH RESPECT TO THE ACCURACY OR COMPLETENESS OF THE CONTENTS OF THIS PUBLICATION AND RESERVES THE RIGHT TO MAKE CHANGES TO SPECIFICATIONS AND PRODUCT DESCRIPTIONS AT ANY TIME WITHOUT NOTICE. NO LICENSE, WHETHER EXPRESS, IMPLIED, ARISING BY ESTOPPEL OR OTHERWISE, TO ANY INTELLECTUAL PROPERTY RIGHTS IS GRANTED BY THIS DOCUMENT.

TESTING AND OTHER QUALITY CONTROLS ARE USED TO THE EXTENT NATIONAL DEEMS NECESSARY TO SUPPORT NATIONAL'S PRODUCT WARRANTY. EXCEPT WHERE MANDATED BY GOVERNMENT REQUIREMENTS, TESTING OF ALL PARAMETERS OF EACH PRODUCT IS NOT NECESSARILY PERFORMED. NATIONAL ASSUMES NO LIABILITY FOR APPLICATIONS ASSISTANCE OR BUYER PRODUCT DESIGN. BUYERS ARE RESPONSIBLE FOR THEIR PRODUCTS AND APPLICATIONS USING NATIONAL COMPONENTS. PRIOR TO USING OR DISTRIBUTING ANY PRODUCTS THAT INCLUDE NATIONAL COMPONENTS, BUYERS SHOULD PROVIDE ADEQUATE DESIGN, TESTING AND OPERATING SAFEGUARDS.

EXCEPT AS PROVIDED IN NATIONAL'S TERMS AND CONDITIONS OF SALE FOR SUCH PRODUCTS, NATIONAL ASSUMES NO LIABILITY WHATSOEVER, AND NATIONAL DISCLAIMS ANY EXPRESS OR IMPLIED WARRANTY RELATING TO THE SALE AND/OR USE OF NATIONAL PRODUCTS INCLUDING LIABILITY OR WARRANTIES RELATING TO FITNESS FOR A PARTICULAR PURPOSE, MERCHANTABILITY, OR INFRINGEMENT OF ANY PATENT, COPYRIGHT OR OTHER INTELLECTUAL PROPERTY RIGHT.

LIFE SUPPORT POLICY

NATIONAL'S PRODUCTS ARE NOT AUTHORIZED FOR USE AS CRITICAL COMPONENTS IN LIFE SUPPORT DEVICES OR SYSTEMS WITHOUT THE EXPRESS PRIOR WRITTEN APPROVAL OF THE CHIEF EXECUTIVE OFFICER AND GENERAL COUNSEL OF NATIONAL SEMICONDUCTOR CORPORATION. As used herein:

Life support devices or systems are devices which (a) are intended for surgical implant into the body, or (b) support or sustain life and whose failure to perform when properly used in accordance with instructions for use provided in the labeling can be reasonably expected to result in a significant injury to the user. A critical component is any component in a life support device or system whose failure to perform can be reasonably expected to cause the failure of the life support device or system or to affect its safety or effectiveness.

National Semiconductor and the National Semiconductor logo are registered trademarks of National Semiconductor Corporation. All other brand or product names may be trademarks or registered trademarks of their respective holders.

Copyright© 2010 National Semiconductor Corporation

For the most current product information visit us at www.national.com



National Semiconductor Americas Technical Support Center
 Email: support@nsc.com
 Tel: 1-800-272-9959

National Semiconductor Europe Technical Support Center
 Email: europe.support@nsc.com

National Semiconductor Asia Pacific Technical Support Center
 Email: ap.support@nsc.com

National Semiconductor Japan Technical Support Center
 Email: jpn.feedback@nsc.com