

LM3445 -120VAC, 8W Isolated Flyback LED Driver

National Semiconductor
Application Note 2034
Steve Solanyk
August 20, 2010



LM3445 - 120VAC, 8W Isolated Flyback LED Driver

Introduction

This demonstration board highlights the performance of a LM3445 based Flyback LED driver solution that can be used to power a single LED string consisting of 4 to 8 series connected LEDs from an 90 V_{RMS} to 135 V_{RMS}, 60 Hz input power supply. The key performance characteristics under typical operating conditions are summarized in this application note.

This is a two-layer board using the bottom and top layer for component placement. The demonstration board can be modified to adjust the LED forward current, the number of series connected LEDs that are driven and the switching frequency. Refer to the LM3445 datasheet for detailed instructions.

A bill of materials is included that describes the parts used on this demonstration board. A schematic and layout have also been included along with measured performance characteristics.

Key Features

- Drop-in compatibility with TRIAC dimmers
- Line injection circuitry enables PFC values greater than 0.95
- Adjustable LED current and switching frequency
- Flicker free operation

Applications

- Retro-fit TRIAC Dimming
- Solid State Lighting
- Industrial and Commercial Lighting
- Residential Lighting

Performance Specifications

Based on an LED V_f = 3.4V

Symbol	Parameter	Min	Typ	Max
V _{IN}	Input voltage	90 V _{RMS}	120 V _{RMS}	135 V _{RMS}
V _{OUT}	LED string voltage	13 V	20 V	27 V
I _{LED}	LED string average current	-	365 mA	-
P _{OUT}	Output power	-	7.3 W	-
f _{sw}	Switching frequency	-	78.5 kHz	-

Demo Board

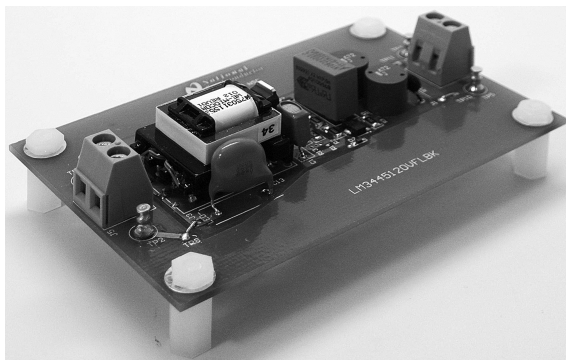

30115268

LED Current vs. Input Voltage (using Dimmer)

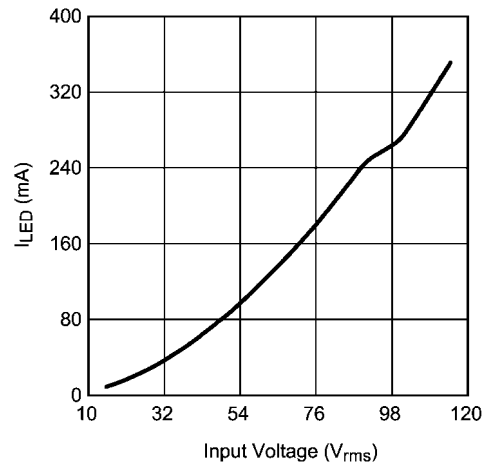

30115274

LM3445 120VAC, 8W Isolated Flyback LED Driver Demo Board Schematic

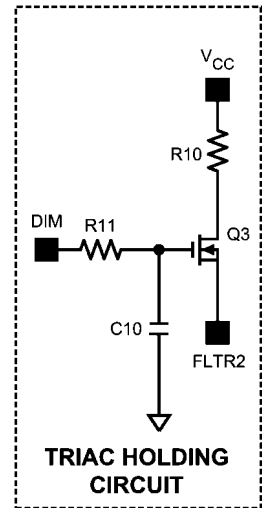
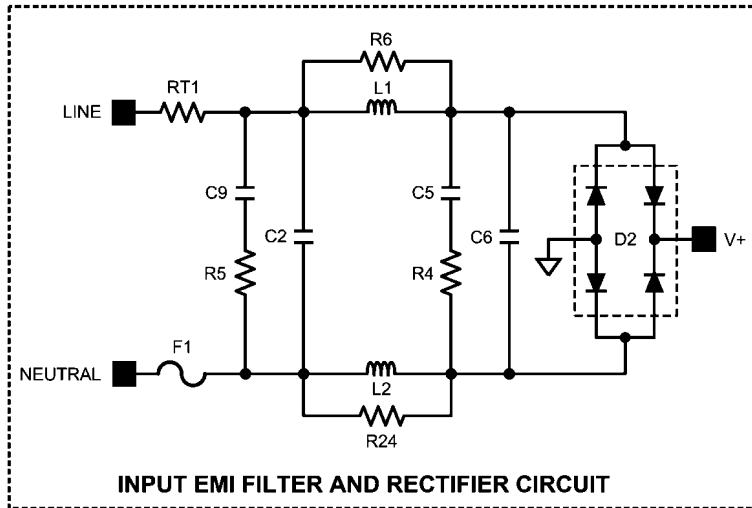
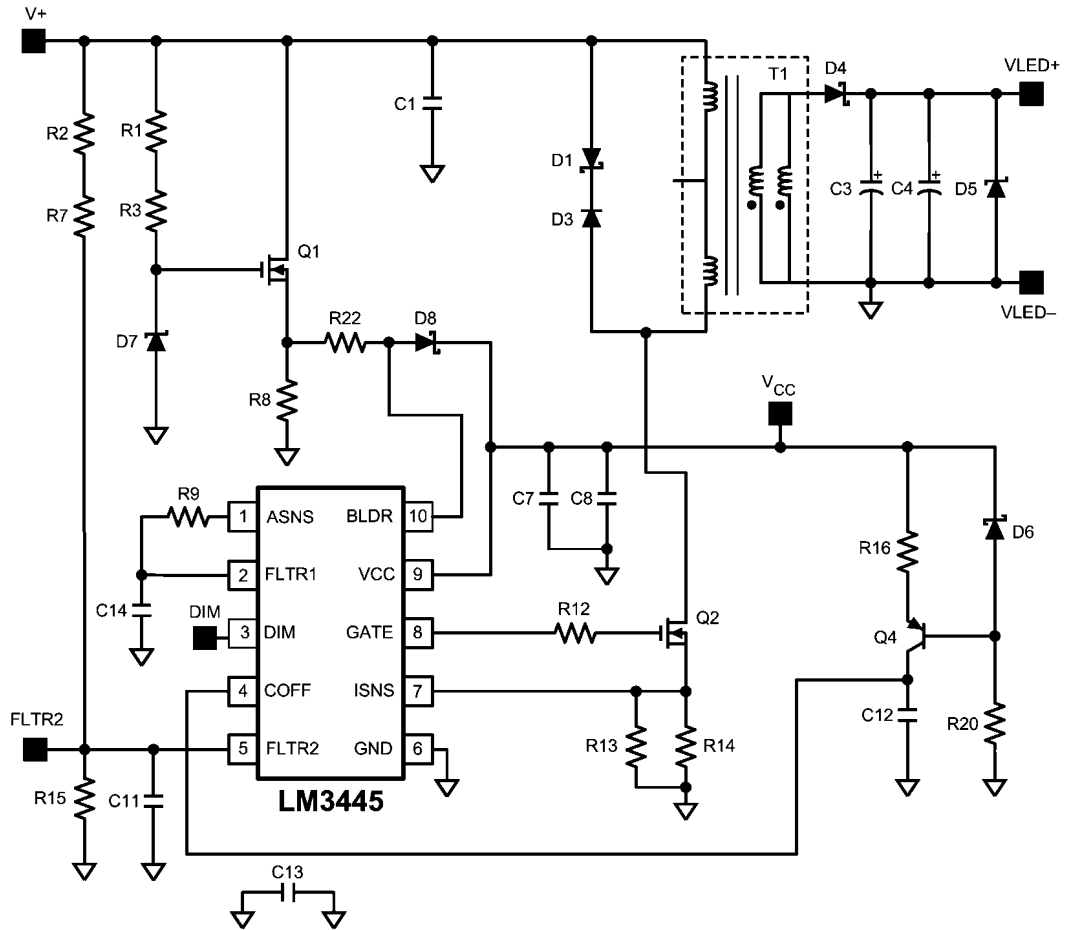

30115201

- Warning:** The LM3445 evaluation board has exposed high voltage components that present a shock hazard. Caution must be taken when handling the evaluation board. Avoid touching the evaluation board and removing any cables while the evaluation board is operating. Isolating the evaluation board rather than the oscilloscope is highly recommended.
- Warning:** The ground connection on the evaluation board is NOT referenced to earth ground. If an oscilloscope ground lead is connected to the evaluation board ground test point for analysis and AC power is applied, the fuse (F1) will fail open. The oscilloscope should be powered via an isolation transformer before an oscilloscope ground lead is connected to the evaluation board.
- Warning:** The LM3445 evaluation board should not be powered with an open load. For proper operation, ensure that the desired number of LEDs are connected at the output before applying power to the evaluation board.

LM3445 Device Pin-Out

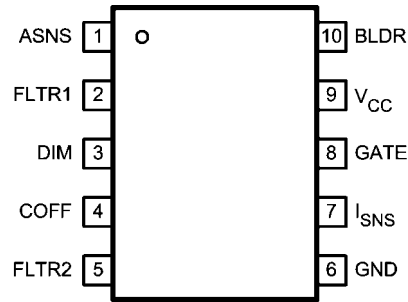

30115202

Pin Description 10 Pin MSOP

Pin #	Name	Description
1	ASNS	PWM output of the triac dim decoder circuit. Outputs a 0 to 4V PWM signal with a duty cycle proportional to the triac dimmer on-time.
2	FLTR1	First filter input. The 120Hz PWM signal from ASNS is filtered to a DC signal and compared to a 1 to 3V, 5.85 kHz ramp to generate a higher frequency PWM signal with a duty cycle proportional to the triac dimmer firing angle. Pull above 4.9V (typical) to tri-state DIM.
3	DIM	Input/output dual function dim pin. This pin can be driven with an external PWM signal to dim the LEDs. It may also be used as an output signal and connected to the DIM pin of other LM3445 or LED drivers to dim multiple LED circuits simultaneously.
4	COFF	OFF time setting pin. A user set current and capacitor connected from the output to this pin sets the constant OFF time of the switching controller.
5	FLTR2	Second filter input. A capacitor tied to this pin filters the PWM dimming signal to supply a DC voltage to control the LED current. Could also be used as an analog dimming input.
6	GND	Circuit ground connection.
7	ISNS	LED current sense pin. Connect a resistor from main switching MOSFET source, ISNS to GND to set the maximum LED current.
8	GATE	Power MOSFET driver pin. This output provides the gate drive for the power switching MOSFET of the buck controller.
9	V _{CC}	Input voltage pin. This pin provides the power for the internal control circuitry and gate driver.
10	BLDR	Bleeder pin. Provides the input signal to the angle detect circuitry as well as a current path through a switched 230Ω resistor to ensure proper firing of the triac dimmer.

Bill of Materials

Designator	Description	Manufacturer	Part Number
AA1	Printed Circuit Board	-	551600457-001A
C1	CAP .047UF 630V METAL POLYPRO	EPCOS Inc	B32559C6473K000
C2	CAP 10000PF X7R 250VAC X2 2220	Murata Electronics North America	GA355DR7GB103KY02L
C3, C4	CAP 330UF 35V ELECT PW	Nichicon	UPW1V331MPD6
C5	CAP CER .33UF 250V X7R 1812	TDK Corporation	C4532X7R2E334K
C6	CAP .10UF 305VAC EMI SUPPRESSION	EPCOS	B32921C3104M
C7	CAP, CERM, 0.1µF, 16V, +/-10%, X7R, 0805	Kemet	C0805C104K4RACTU
C8	CAP CER 47UF 16V X5R 1210	MuRata	GRM32ER61C476ME15L
C9	CAP CER .10UF 250V X7R 10% 1206	TDK	C3216X7R2E104K
C10	CAP CER .22UF 16V X7R 0603	MuRata	GRM188R71C224KA01D
C11	CAP CER 2200PF 50V 10% X7R 0603	MuRata	GRM188R71H222KA01D
C12	CAP CER 330PF 50V 5% C0G 0603	MuRata	GRM1885C1H331JA01D
C13	CAP CER 2200PF 250VAC X1Y1 RAD	TDK Corporation	CD12-E2GA222MYNS
C14	CAP CERM .47UF 10% 25V X5R 0805	AVX	08053D474KAT2A
D1	DIODE TVS 150V 600W UNI 5% SMB	Littlefuse	SMAJ120A
D2	RECT BRIDGE GP 600V 0.5A MINIDIP	Diodes Inc.	RH06-T
D3	DIODE RECT GP 1A 1000V MINI-SMA	Comchip Technology	CGRM4007-G
D4	DIODE SCHOTTKY 100V 1A SMA	ST Microelectronics	STPS1H100A
D5	DIODE ZENER 30V 1.5W SMA	ON Semiconductor	1SMA5936BT3G
D6	DIODE ZENER 5.1V 200MW SOD-523F	Fairchild Semiconductor	MM5Z5V1
D7	DIODE ZENER 12V 200MW	Fairchild Semiconductor	MM5Z12V
D8	DIODE SWITCH 200V 200MW	Diode Inc	BAV20WS-7-F
F1	FUSE BRICK 1A 125V FAST 6125FA	Cooper/Bussmann	6125FA
J1, J2, J3, J4, TP8, TP9, TP10	16 GA WIRE HOLE, 18 GA WIRE HOLE	3M	923345-02-C
J5, J6	Conn Term Block, 2POS, 5.08mm PCB	Phoenix Contact	1715721
L1, L2	INDUCTOR 4700UH .13A RADIAL	TDK Corporation	TSL0808RA-472JR13-PF
Q1	MOSFET N-CH 600V 90MA SOT-89	Infineon Technologies	BSS225 L6327
Q2	MOSFET N-CH 600V 1.8A TO-251	Infineon Technology	SPU02N60S5
Q3	MOSFET N-CH 100V 170MA SC70-3	Diodes Inc	BSS123W-7-F
Q4	TRANS GP SS PNP 40V SOT323	On Semiconductor	MMBT3906WT1G
R1, R3	RES 200K OHM 1/4W 5% 1206 SMD	Vishay-Dale	CRCW1206200KJNEA
R2, R7	RES, 309k ohm, 1%, 0.25W, 1206	Vishay-Dale	CRCW1206309KFKEA
R4, R5	RES, 430 ohm, 5%, 0.25W, 1206	Vishay-Dale	CRCW1206430RJNEA
R6, R24	RES, 10.5k ohm, 1%, 0.125W, 0805	Vishay-Dale	CRCW080510K5FKEA
R8, R11	RES 49.9K OHM 1/10W 1% 0603 SMD	Vishay-Dale	CRCW060349K9FKEA
R9	RES 100K OHM 1/10W 1% 0603 SMD	Vishay-Dale	CRCW0603100KFKEA
R10	DNP	-	-
R12	RES 4.7 OHM 1/10W 5% 0603 SMD	Vishay-Dale	CRCW06034R70JNEA
R13	RES 10 OHM 1/8W 5% 0805 SMD	Vishay-Dale	CRCW080510R0JNEA
R14	RES 1.50 OHM 1/4W 1% 1206 SMD	Vishay-Dale	CRCW12061R50FNEA
R15	RES 3.48K OHM 1/10W 1% 0603 SMD	Vishay-Dale	CRCW06033K48FKEA
R16	RES 75.0K OHM 1/10W 1% 0603 SMD	Vishay-Dale	CRCW060375K0FKEA
R20	RES 30.1K OHM 1/10W 1% 0603 SMD	Vishay-Dale	CRCW060330K1FKEA
R22	RES 40.2 OHM 1/8W 1% 0805 SMD	Vishay-Dale	CRCW080540R2FKEA
RT1	CURRENT LIMITOR INRUSH 60OHM 20%	Cantherm	MF72-060D5
T1	Transformer	Würth Electronics	750311553 Rev. 01

Designator	Description	Manufacturer	Part Number
TP2-TP5	Terminal, Turret, TH, Double	Keystone Electronics	1502-2
TP7	TEST POINT ICT	-	-
U1	Triac Dimmable Offline LED Driver, PowerWise	National Semiconductor	LM3445MM

Demo Board Wiring Overview

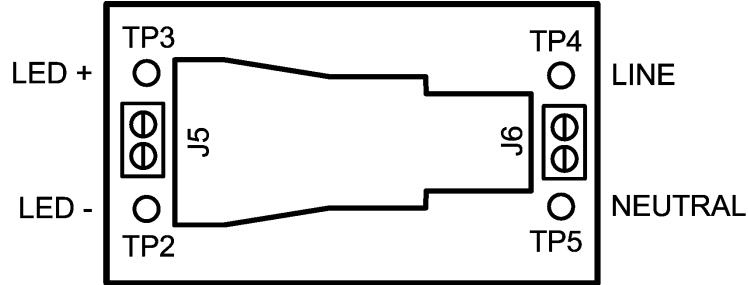

Wiring Connection Diagram

30115243

Test Point	Name	I/O	Description
TP3	LED +	Output	LED Constant Current Supply Supplies voltage and constant-current to anode of LED string.
TP2	LED -	Output	LED Return Connection (not GND) Connects to cathode of LED string. Do NOT connect to GND.
TP4	LINE	Input	AC Line Voltage Connects directly to AC line or output of TRIAC dimmer of a 120VAC system.
TP5	NEUTRAL	Input	AC Neutral Connects directly to AC neutral of a 120VAC system.

Demo Board Assembly

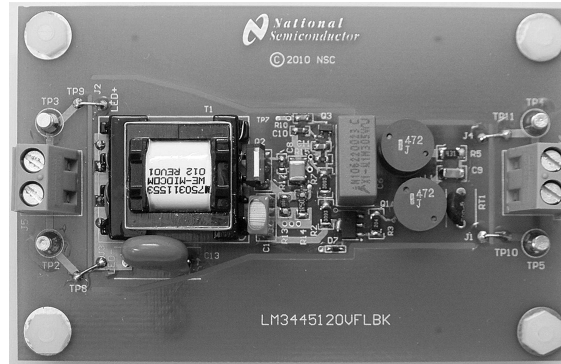

Top View

30115269

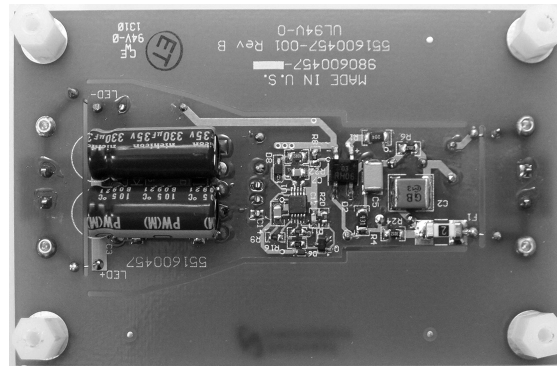

Bottom View

30115270

Typical Performance Characteristics (Note 1)

**Efficiency vs. Line Voltage
Original Circuit**

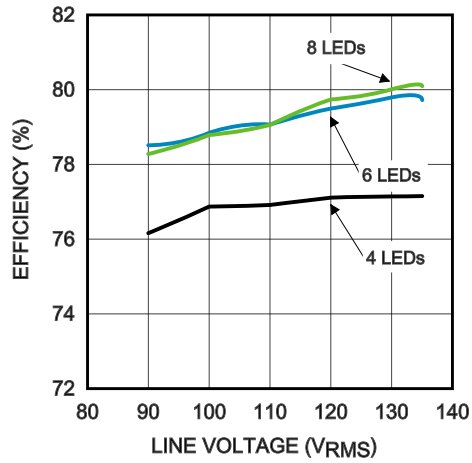

30115287

**Efficiency vs. Line Voltage
Modified Circuits**

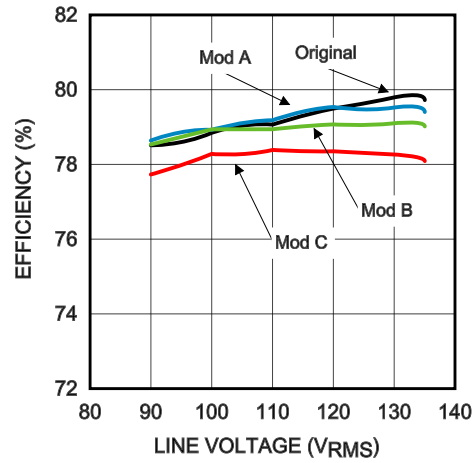

30115288

**LED Current vs. Line Voltage
Original Circuit**

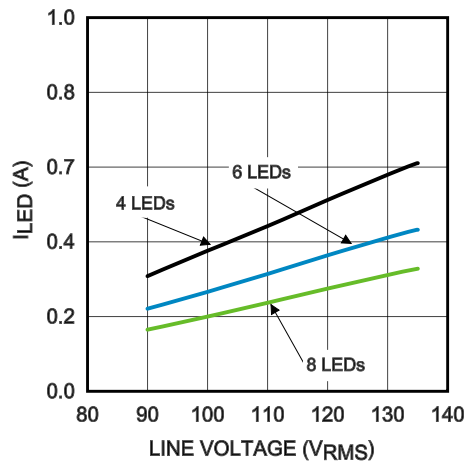

30115289

**LED Current vs. Line Voltage
Modified Circuits**

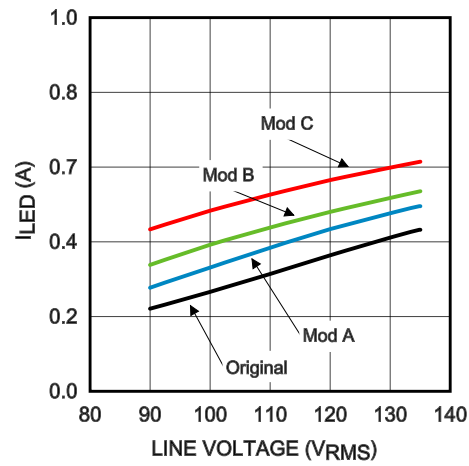

30115290

**Power Factor vs. Line Voltage
Original Circuit**

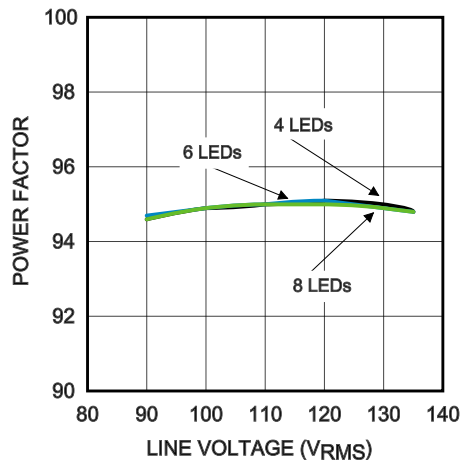

30115291

**Power Factor vs. Line Voltage
Modified Circuits**

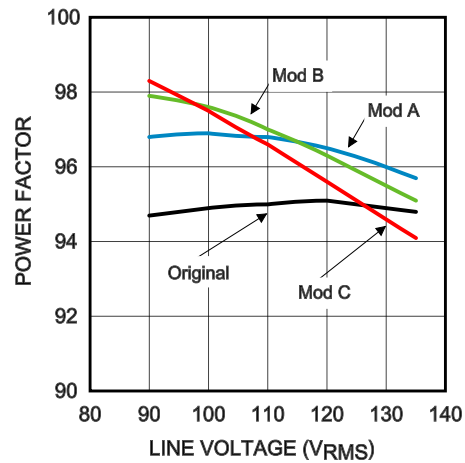

30115292

**Output Power vs. Line Voltage
Original Circuit**

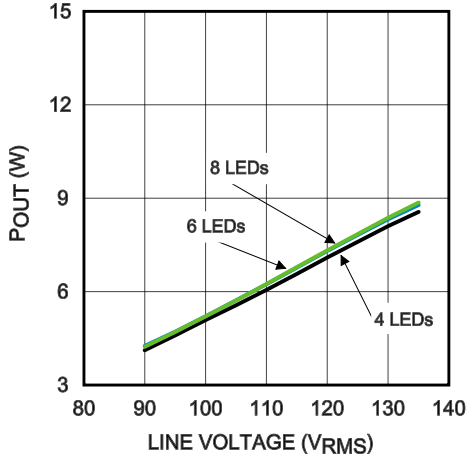

30115293

**Output Power vs. Line Voltage
Modified Circuits**

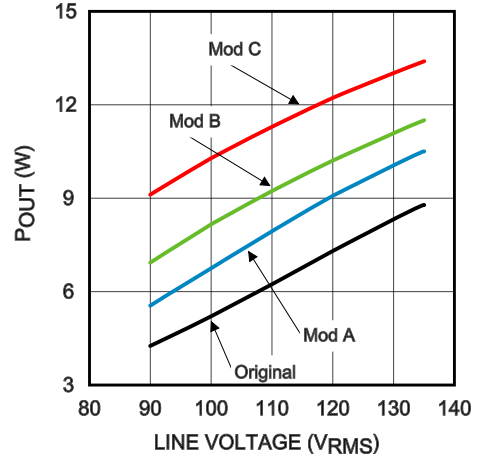

30115294

**Power MOSFET Drain Voltage Waveform
(VIN = 120VRMS, 6 LEDs, ILED = 350mA)**

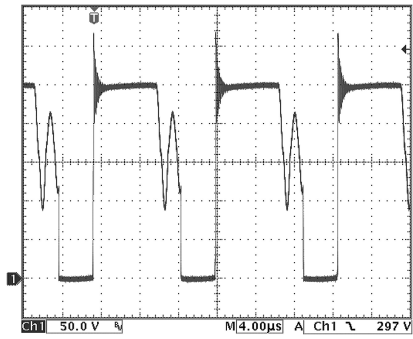

30115296

**Current Sense Waveform
(VIN = 120VRMS, 6 LEDs, ILED = 350mA)**

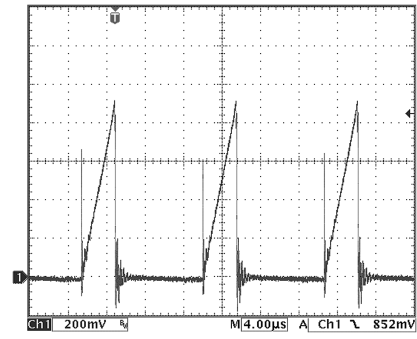

30115297

**FLTR2 Waveform
(VIN = 120VRMS, 6 LEDs, ILED = 350mA)**

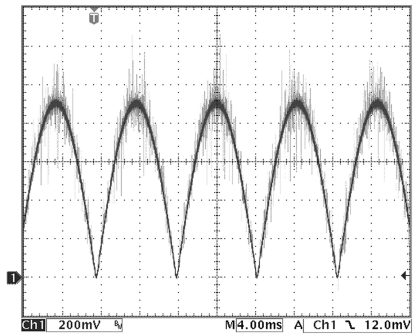

30115298

Note 1: Original Circuit: R14 = 1.50Ω; Modification A: R14 = 1.20Ω; Modification B: R14 = 1.00Ω; Modification C: R14 = 0.75Ω

PCB Layout

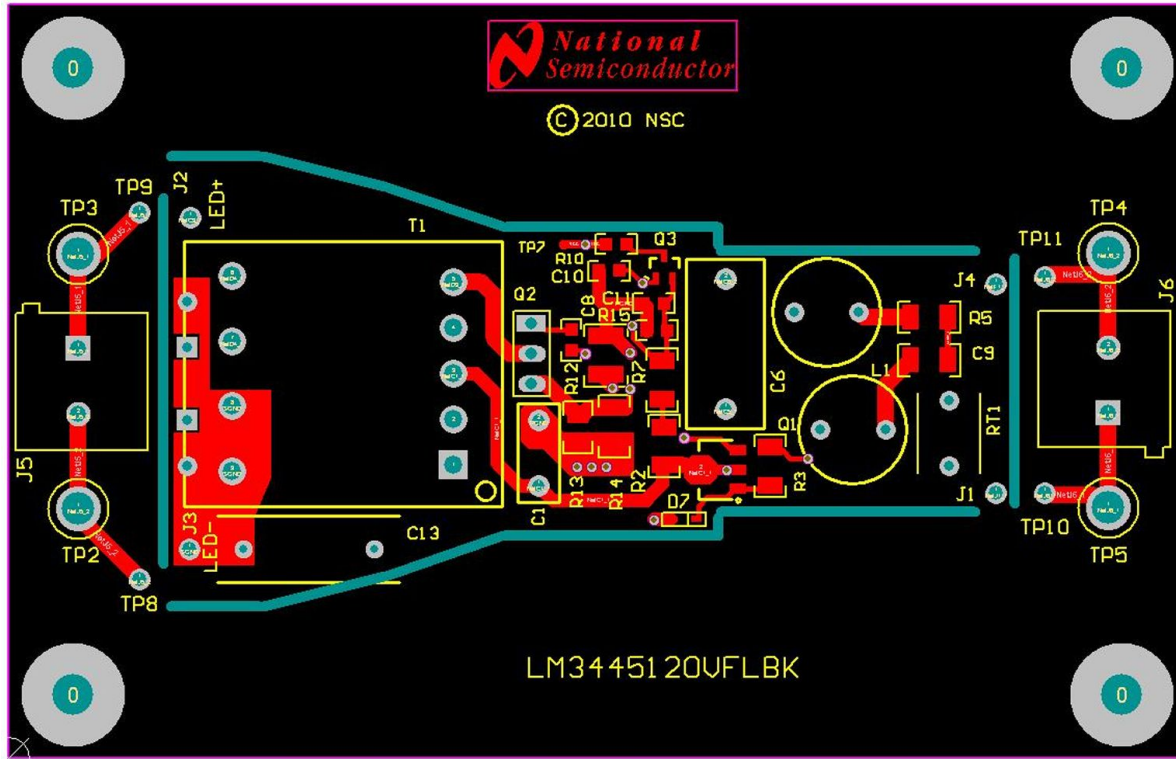

Top Layer

30115209

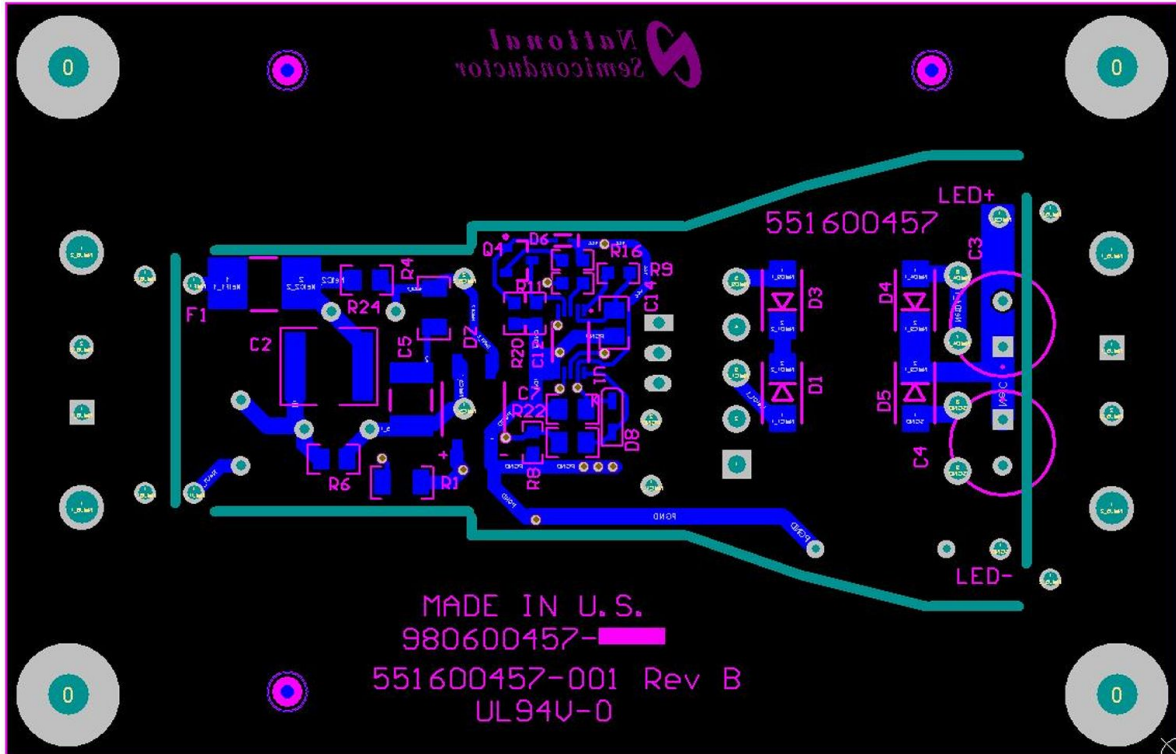

Bottom Layer

30115210

Transformer Design

Mfg: Wurth Electronics, Part #: 750311553 Rev. 01

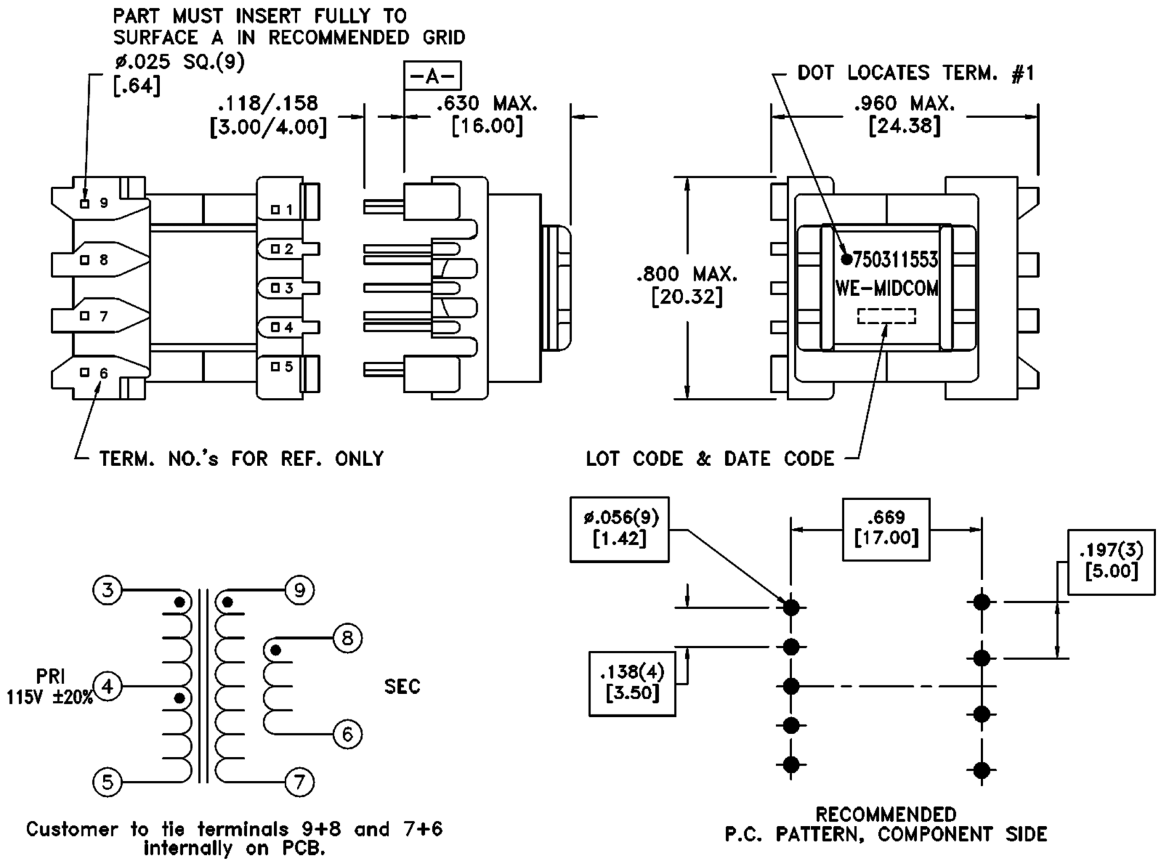

30115299

ELECTRICAL SPECIFICATIONS @ 25°C unless otherwise noted:

PARAMETER	TEST CONDITIONS	VALUE
D.C. RESISTANCE	3-5 @20°C	1.35 ohms max.
D.C. RESISTANCE	8-6 @20°C	0.284 ohms max.
D.C. RESISTANCE	9-7 @20°C	0.284 ohms max.
INDUCTANCE	3-5 100kHz, 100mVAC, Ls	803.5uH \pm 10%
INDUCTANCE	9-7 100kHz, 100mVAC, Ls	50.2uH \pm 10%
INDUCTANCE	8-6 100kHz, 100mVAC, Ls	50.2uH \pm 10%
LEAKAGE INDUCTANCE	tie(9+8+7+6), 100kHz, 100mVAC, Ls	5.50uH typ., 7.0uH max.
DIELECTRIC	tie(9+8), 4500VAC, 1 second	4500VAC, 1 minute
URNS RATIO	(3-5):(9-7)	4:1, \pm 2%
URNS RATIO	(3-5):(8-6)	4:1, \pm 2%

GENERAL SPECIFICATIONS:

OPERATING TEMPERATURE RANGE: -40°C to +125°C including temp rise.

Designed to comply with the following requirements as defined by IEC61558-2-17:
 - Reinforced insulation for a primary circuit at a working voltage of 400VDC.

30115214

Experimental Results

The LED driver is designed to accurately emulate an incandescent light bulb and therefore behave as an emulated resistor. The resistor value is determined based on the LED string configuration and the desired output power. The circuit then operates in open-loop, with a fixed duty cycle based on a constant on-time and constant off-time that is set by selecting appropriate circuit components. Like an incandescent lamp, the driver is compatible with both forward and reverse phase dimmers.

NON-DIMMING PERFORMANCE

In steady state, the LED string voltage is measured to be 20.1 V and the average LED current is measured as 365 mA. The 120 Hz current ripple flowing through the LED string was

measured to be 182 mA_{pk-pk} at full load. The magnitude of the ripple is a function of the value of energy storage capacitors connected across the output port and the TRIAC firing angle. The ripple current can be reduced by increasing the value of energy storage capacitor or by increasing the LED string voltage. With TRIAC dimmers, the ripple magnitude is directly proportional to the input power and therefore reduces at lower LED current.

The LED driver switching frequency is measured to be close to the specified 78.5 kHz. The circuit operates with a constant duty cycle of 0.28 and consumes near 9.2 W of input power. The driver steady state performance for an LED string consisting of 6 series LEDs without using a triac dimmer is summarized in the following table.

MEASURED EFFICIENCY AND LINE REGULATION (6 LEDES, NO TRIAC DIMMER)

V_{IN} (V _{RMS})	I_{IN} (mA _{RMS})	P_{IN} (W)	V_{OUT} (V)	I_{LED} (mA)	P_{OUT} (W)	Efficiency (%)	Power Factor
89.98	64	5.44	19.24	222	4.27	78.5	94.7
95.03	67	6.03	19.40	244	4.73	78.5	94.8
100.00	70	6.62	19.55	267	5.22	78.8	94.9
104.97	73	7.24	19.69	291	5.73	79.1	95.0
110.03	76	7.90	19.83	315	6.25	79.1	95.0
115.00	78	8.55	19.95	340	6.78	79.3	95.1
120.05	81	9.21	20.06	365	7.32	79.5	95.1
125.02	83	9.84	20.14	389	7.83	79.6	95.0
129.99	85	10.44	20.22	412	8.33	79.8	94.9
135.04	86	11.02	20.29	433	8.79	79.7	94.8

LED CURRENT, OUTPUT POWER VERSUS NUMBER OF LEDES FOR VARIOUS CIRCUIT MODIFICATIONS ($V_{IN} = 120$ V_{AC}, no Triac Dimmer)

# of LEDES	Original Circuit (Note 2)		Modification A (Note 2)		Modification B (Note 2)		Modification C (Note 2)	
	I_{LED} (mA)	P_{OUT} (W)	I_{LED} (mA)	P_{OUT} (W)	I_{LED} (mA)	P_{OUT} (W)	I_{LED} (mA)	P_{OUT} (W)
4	513	7.11	627	8.83	683	10.03	805	11.91
6	365	7.32	435	9.09	481	10.22	566	12.23
8	276	7.34	334	9.16	367	10.16	431	12.12

Note 2: Original Circuit: R14 = 1.50Ω; Modification A: R14 = 1.20Ω; Modification B: R14 = 1.00Ω; Modification C: R14 = 0.75Ω

DIMMING PERFORMANCE

The LED driver is capable of matching or exceeding the dimming performance of an incandescent lamp. Using a simple rotary TRIAC dimmer, smooth and near logarithmic dimming

performance is achieved. By varying the firing angle of the TRIAC dimmer and measuring the corresponding input and output parameters, the dimming performance of the demonstration board driving 6 LEDs is summarized in the table below.

MEASURED EFFICIENCY AND LINE REGULATION DATA (WITH TRIAC DIMMER)

V_{IN} (V _{RMS})	V_O (V)	I_O (mA)	P_{OUT} (W)
115.0	19.9	351	7.0
110.1	19.8	323	6.4
105.2	19.7	295	5.8
100.4	19.6	269	5.3
95.5	19.6	258	5.0
90.7	19.5	248	4.8
85.2	19.4	222	4.3
80.2	19.3	199	3.8
75.1	19.2	176	3.4
70.8	19.1	159	3.0

V_{IN} (V _{RMS})	V_O (V)	I_O (mA)	P_{OUT} (W)
65.5	18.7	138	2.6
60.5	18.8	120	2.3
55.2	18.6	101	1.9
50.6	18.5	86	1.6
45.7	18.3	72	1.3
39.4	18.0	54	1.0
34.2	17.8	42	0.7
30.3	17.6	33	0.6
26.0	17.4	25	0.4
20.0	17.0	15	0.3
15.2	16.6	9	0.1

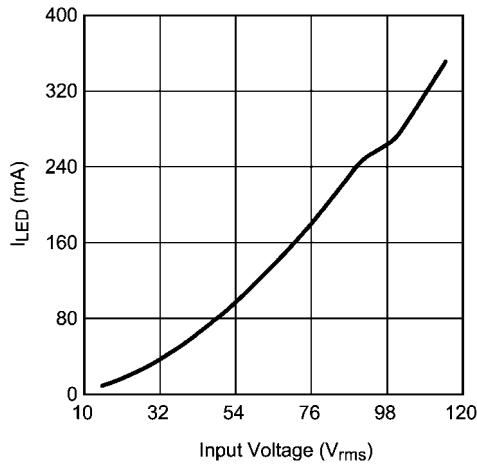

30115274
LED Current vs. Input Voltage (using Dimmer)

POWER FACTOR PERFORMANCE

The LED driver is able to achieve close to unity power factor (P.F. ~ 0.95) which meets Energy Star requirements. This design also exhibits low current harmonics as a percentage

of the fundamental current (as shown in the following figure) and therefore meets the requirements of the IEC 61000-3-2 Class-3 standard.

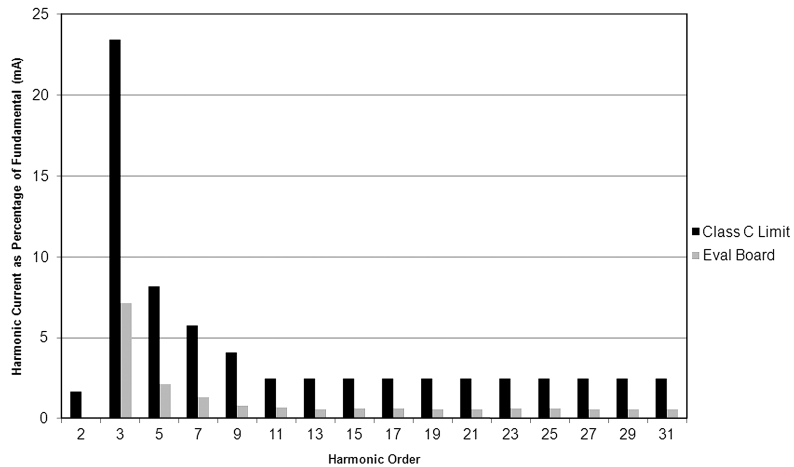

30115295
Current Harmonic Performance vs. EN/IEC61000-3-2 Class C Limits

Circuit Operation With Rotary Forward Phase Triac Dimmer

The dimming operation of the circuit was verified using a forward phase rotary triac dimmer. Waveforms captured at different dimmer settings are shown below:

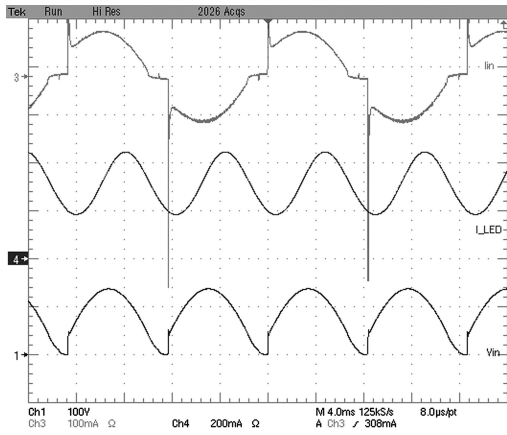

Forward phase circuit at full brightness

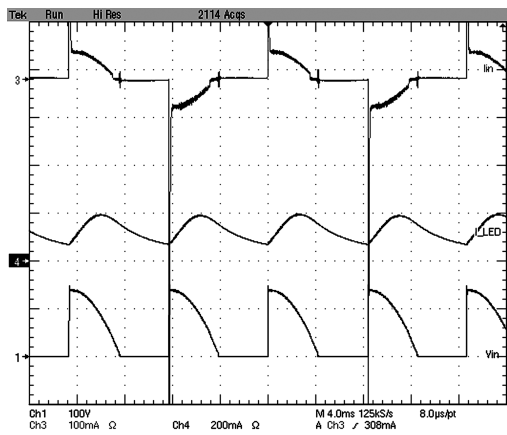

Forward phase circuit at 90° firing angle

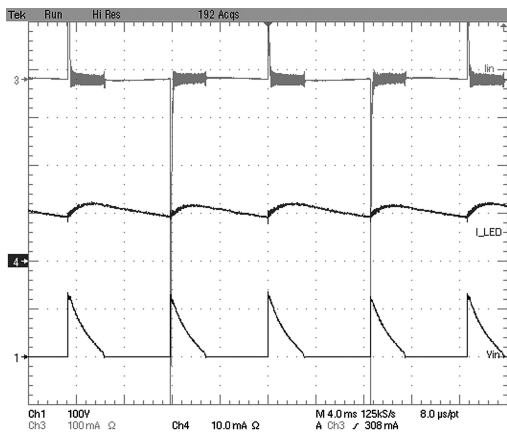

Forward phase circuit at 150° firing angle

Circuit Operation With Reverse Phase Triac Dimmer

The circuit operation was also verified using a reverse phase dimmer and waveforms captured at different dimmer settings are shown below:

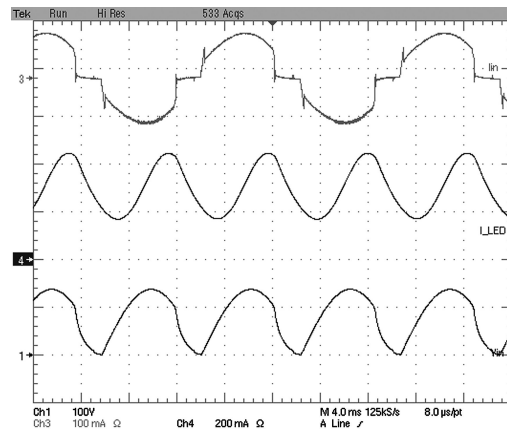

Reverse phase circuit at full brightness

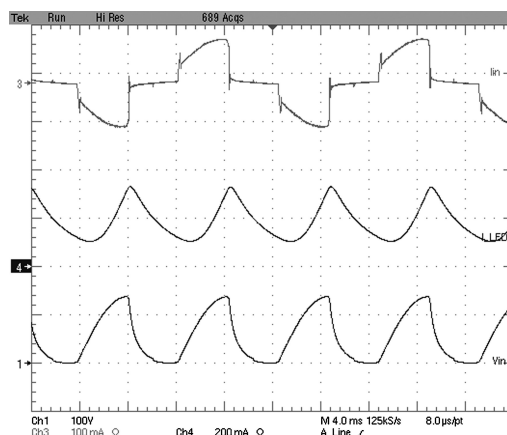

Reverse phase circuit at 90° firing angle

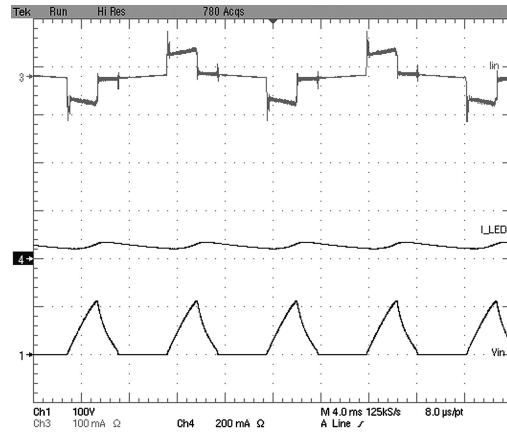

Reverse phase circuit at 150° firing angle

Electromagnetic Interference (EMI)

The EMI input filter of this evaluation board is configured as shown in the following circuit diagram.

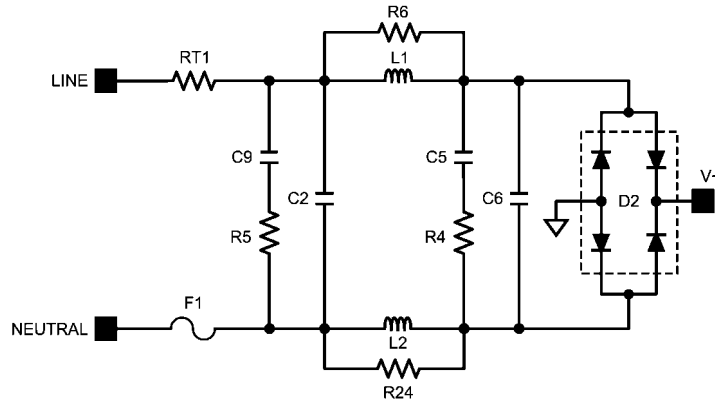

30115267

FIGURE 1. Input EMI Filter and Rectifier Circuit

In order to get a quick estimate of the EMI filter performance, only the PEAK conductive EMI scan was measured and the

data was compared to the Class B conducted EMI limits published in FCC – 47, section 15.

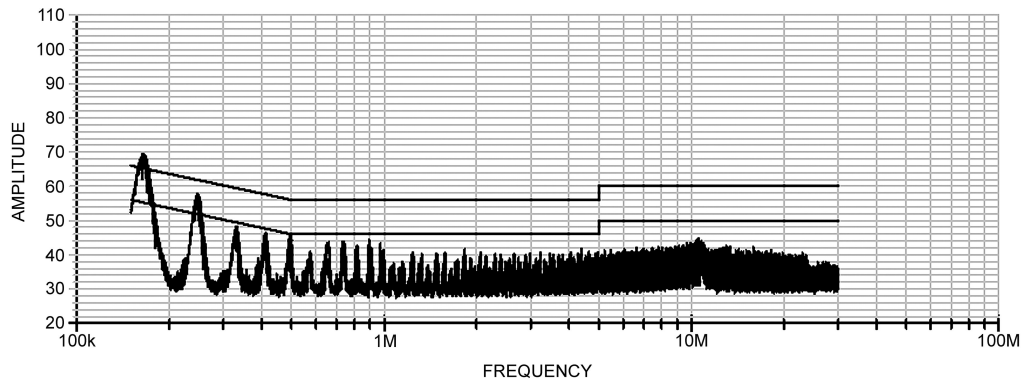

30115277

FIGURE 2. Peak Conductive EMI scan per CISPR-22, Class B Limits

If an additional 33nF of input capacitance (i.e. C6) is utilized in the input filter, the EMI conductive performance is further improved as shown in the following figure.

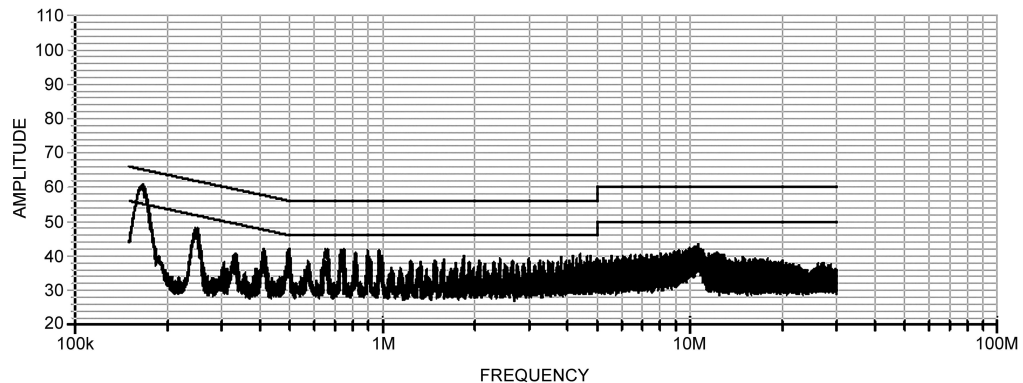

30115278

FIGURE 3. Peak Conductive EMI scan with additional 33nF of input capacitance

Thermal Analysis

The board temperature was measured using an IR camera (HIS-3000, Wahl) while running under the following conditions:

$$V_{IN} = 120 V_{RMS}$$

$$I_{LED} = 365 \text{ mA}$$

$$\# \text{ of LEDs} = 6$$

$$P_{OUT} = 7.3 \text{ W}$$

The results are shown in the following figures.

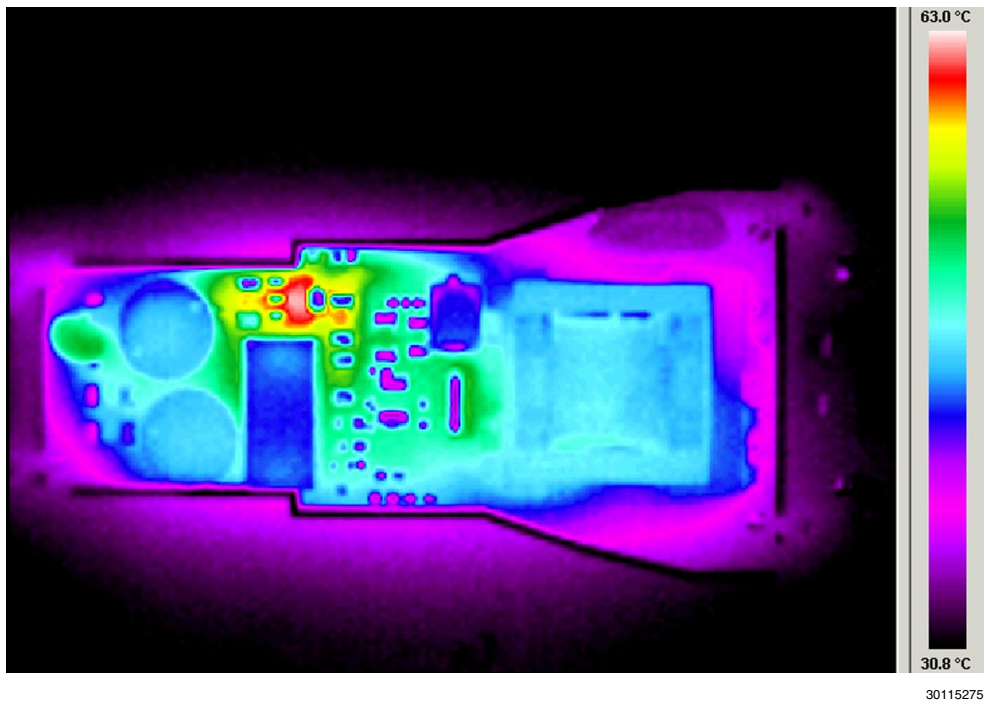

FIGURE 4. Top Side Thermal Scan

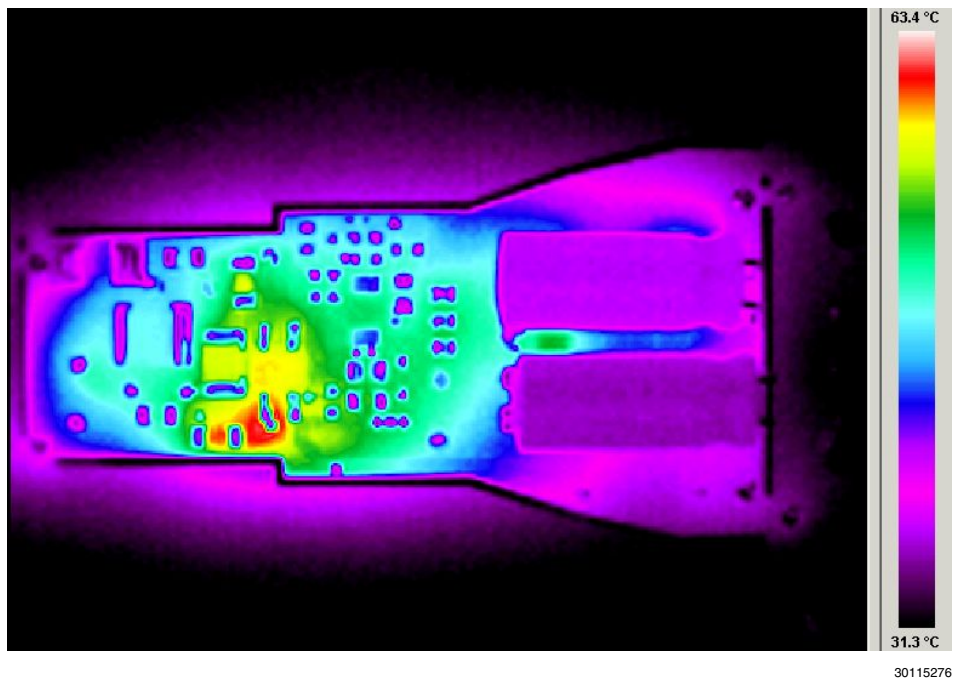

FIGURE 5. Bottom Side Thermal Scan

Circuit Analysis and Explanations

INJECTING LINE VOLTAGE INTO FILTER-2 (achieving PFC > 0.95)

If a small portion (750mV to 1.00V) of line voltage is injected at FLTR2 of the LM3445, the circuit is essentially turned into a constant power flyback as shown in Figure 6.

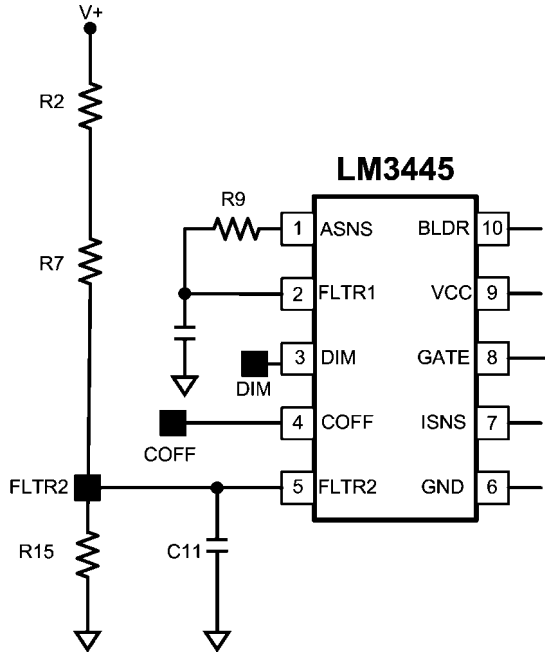

FIGURE 6. Line Voltage Injection Circuit

The LM3445 works as a constant off-time controller normally, but by injecting the 1.0V rectified AC voltage into the FLTR2

pin, the on-time can be made to be constant. With a DCM Flyback, Δi needs to increase as the input voltage line increases. Therefore a constant on-time (since inductor L is constant) can be obtained.

By using the line voltage injection technique, the FLTR2 pin has the voltage wave shape shown in Figure 7 on it with no triac dimmer in-line. Voltage at V_{FLTR2} peak should be kept below 1.25V. At 1.25V current limit is tripped. C11 is small enough not to distort the AC signal but adds a little filtering.

Although the on-time is probably never truly constant, it can be observed in Figure 8 how (by adding the rectified voltage) the on-time is adjusted.

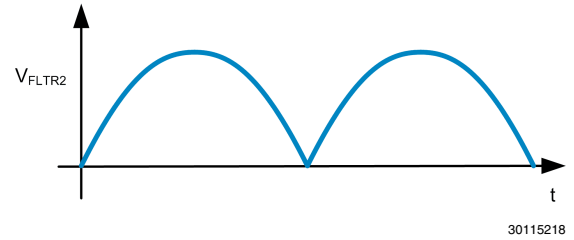

FIGURE 7. FLTR2 Waveform with No Dimmer

For this evaluation board, the following resistor values are used:

$R2 = R7 = 309k\Omega$

$R15 = 3.48k\Omega$

Therefore the voltages observed on the FLTR2 pin will be as follows for listed input voltages:

For $V_{IN} = 90V_{RMS}$, $V_{FLTR2} = 0.71V$

For $V_{IN} = 120V_{RMS}$, $V_{FLTR2} = 0.95V$

For $V_{IN} = 135V_{RMS}$, $V_{FLTR2} = 1.07V$

Using this technique, a power factor greater than 0.95 can be achieved without additional passive active power factor control (PFC) circuitry.

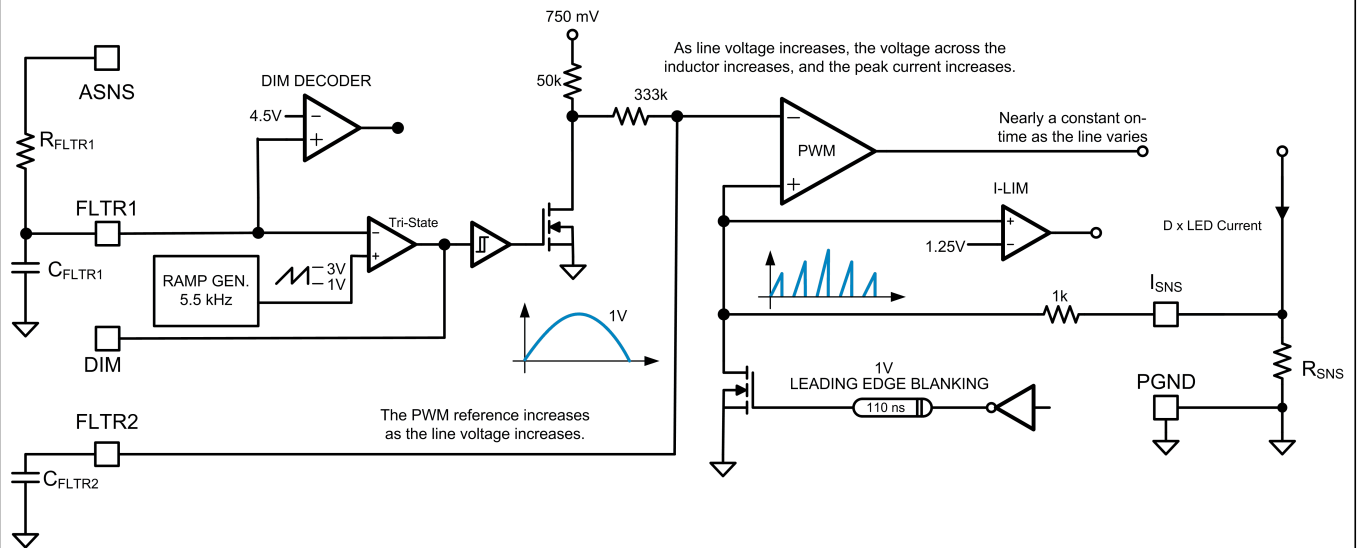

FIGURE 8. Typical Operation of FLTR2 Pin

Notes

AN-2034

Notes

For more National Semiconductor product information and proven design tools, visit the following Web sites at:
www.national.com

Products		Design Support	
Amplifiers	www.national.com/amplifiers	WEBENCH® Tools	www.national.com/webench
Audio	www.national.com/audio	App Notes	www.national.com/appnotes
Clock and Timing	www.national.com/timing	Reference Designs	www.national.com/refdesigns
Data Converters	www.national.com/adc	Samples	www.national.com/samples
Interface	www.national.com/interface	Eval Boards	www.national.com/evalboards
LVDS	www.national.com/lvds	Packaging	www.national.com/packaging
Power Management	www.national.com/power	Green Compliance	www.national.com/quality/green
Switching Regulators	www.national.com/switchers	Distributors	www.national.com/contacts
LDOs	www.national.com/lido	Quality and Reliability	www.national.com/quality
LED Lighting	www.national.com/led	Feedback/Support	www.national.com/feedback
Voltage References	www.national.com/vref	Design Made Easy	www.national.com/easy
PowerWise® Solutions	www.national.com/powerwise	Applications & Markets	www.national.com/solutions
Serial Digital Interface (SDI)	www.national.com/sdi	Mil/Aero	www.national.com/milaero
Temperature Sensors	www.national.com/tempensors	SolarMagic™	www.national.com/solarmagic
PLL/VCO	www.national.com/wireless	PowerWise® Design University	www.national.com/training

THE CONTENTS OF THIS DOCUMENT ARE PROVIDED IN CONNECTION WITH NATIONAL SEMICONDUCTOR CORPORATION ("NATIONAL") PRODUCTS. NATIONAL MAKES NO REPRESENTATIONS OR WARRANTIES WITH RESPECT TO THE ACCURACY OR COMPLETENESS OF THE CONTENTS OF THIS PUBLICATION AND RESERVES THE RIGHT TO MAKE CHANGES TO SPECIFICATIONS AND PRODUCT DESCRIPTIONS AT ANY TIME WITHOUT NOTICE. NO LICENSE, WHETHER EXPRESS, IMPLIED, ARISING BY ESTOPPEL OR OTHERWISE, TO ANY INTELLECTUAL PROPERTY RIGHTS IS GRANTED BY THIS DOCUMENT.

TESTING AND OTHER QUALITY CONTROLS ARE USED TO THE EXTENT NATIONAL DEEMS NECESSARY TO SUPPORT NATIONAL'S PRODUCT WARRANTY. EXCEPT WHERE MANDATED BY GOVERNMENT REQUIREMENTS, TESTING OF ALL PARAMETERS OF EACH PRODUCT IS NOT NECESSARILY PERFORMED. NATIONAL ASSUMES NO LIABILITY FOR APPLICATIONS ASSISTANCE OR BUYER PRODUCT DESIGN. BUYERS ARE RESPONSIBLE FOR THEIR PRODUCTS AND APPLICATIONS USING NATIONAL COMPONENTS. PRIOR TO USING OR DISTRIBUTING ANY PRODUCTS THAT INCLUDE NATIONAL COMPONENTS, BUYERS SHOULD PROVIDE ADEQUATE DESIGN, TESTING AND OPERATING SAFEGUARDS.

EXCEPT AS PROVIDED IN NATIONAL'S TERMS AND CONDITIONS OF SALE FOR SUCH PRODUCTS, NATIONAL ASSUMES NO LIABILITY WHATSOEVER, AND NATIONAL DISCLAIMS ANY EXPRESS OR IMPLIED WARRANTY RELATING TO THE SALE AND/OR USE OF NATIONAL PRODUCTS INCLUDING LIABILITY OR WARRANTIES RELATING TO FITNESS FOR A PARTICULAR PURPOSE, MERCHANTABILITY, OR INFRINGEMENT OF ANY PATENT, COPYRIGHT OR OTHER INTELLECTUAL PROPERTY RIGHT.

LIFE SUPPORT POLICY

NATIONAL'S PRODUCTS ARE NOT AUTHORIZED FOR USE AS CRITICAL COMPONENTS IN LIFE SUPPORT DEVICES OR SYSTEMS WITHOUT THE EXPRESS PRIOR WRITTEN APPROVAL OF THE CHIEF EXECUTIVE OFFICER AND GENERAL COUNSEL OF NATIONAL SEMICONDUCTOR CORPORATION. As used herein:

Life support devices or systems are devices which (a) are intended for surgical implant into the body, or (b) support or sustain life and whose failure to perform when properly used in accordance with instructions for use provided in the labeling can be reasonably expected to result in a significant injury to the user. A critical component is any component in a life support device or system whose failure to perform can be reasonably expected to cause the failure of the life support device or system or to affect its safety or effectiveness.

National Semiconductor and the National Semiconductor logo are registered trademarks of National Semiconductor Corporation. All other brand or product names may be trademarks or registered trademarks of their respective holders.

Copyright© 2010 National Semiconductor Corporation

For the most current product information visit us at www.national.com



National Semiconductor Americas Technical Support Center
 Email: support@nsc.com
 Tel: 1-800-272-9959

National Semiconductor Europe Technical Support Center
 Email: europe.support@nsc.com

National Semiconductor Asia Pacific Technical Support Center
 Email: ap.support@nsc.com

National Semiconductor Japan Technical Support Center
 Email: jpn.feedback@nsc.com