

LM3445 208-277V_{AC} Non-Isolated Evaluation PCB

National Semiconductor
 Application Note 1995
 Tim Sullivan
 October 23, 2009



LM3445 208-277V_{AC} Non-Isolated Evaluation PCB

Introduction

The demonstration board included in this shipment is capable of converting a 176V_{AC} to 305V_{AC} input that has been phase dimmed to drive multiple LED's at up to 500 mA average current. The evaluation board utilizing the LM3445 will automatically adjust the LED current and light output in relation to the triac firing angle.

The target solution for this design was 230V_{AC} input driving 8 series connected white LEDs. In this configuration the LM3445 will run at a nominal switching frequency of 80 kHz and supply a maximum of 350 mA.

This is a four-layer board using the bottom and top layer for component placement. The demonstration board can be modified to adjust the LED forward current, the number of series connected LEDs and switching frequency.

A supplied bill of materials describes the parts used on this demonstration board. A schematic and layout have also been included along with measured performance characteristics. The noted operation restrictions are valid only for the demonstration board as shipped with the schematic below. As is, the board is capable driving 8 to 16 series connected LEDs with noted performance, but the evaluation board may be modified to accept fewer or additional series LEDs with some simple design modification. Refer to the Customization Section below and the LM3445 datasheet for detailed instructions.

Key Features

- V_{in} range covering 208, 220, 230, 240, and 277V_{AC}
- Multiple output configurations are possible

Simplified LM3445 Schematic and Efficiency Plot

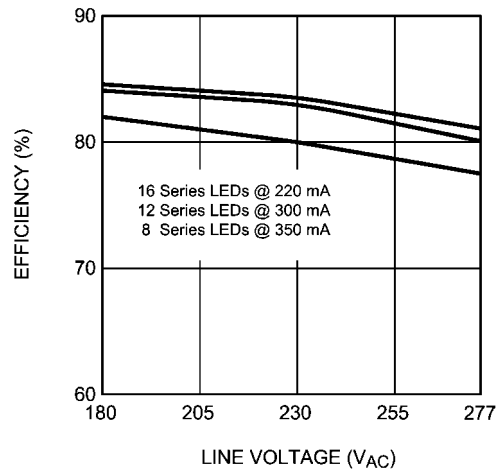
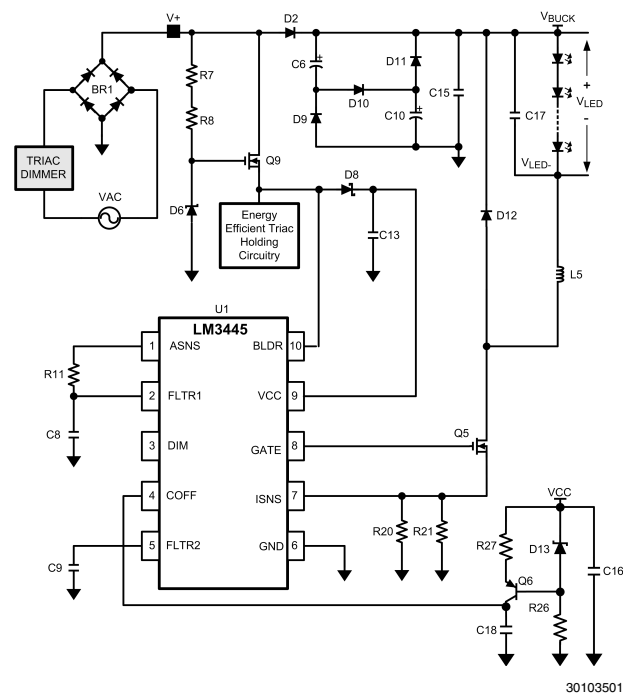

Warning: This LM3445 evaluation PCB is a non-isolated design. The ground connection on the evaluation board is NOT referenced to earth ground. If an oscilloscope ground lead is connected to the evaluation board ground test point for analysis, and AC power is applied, the fuse (F1) will fail open. The oscilloscope should be powered via an isolation transformer before an oscilloscope ground lead is connected to the evaluation board.

Pin-Out

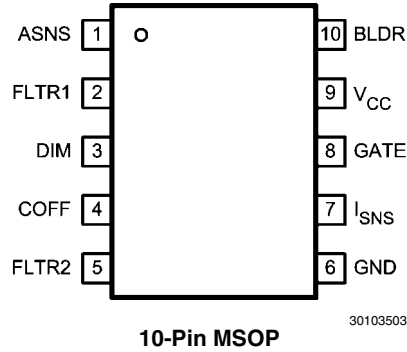

Pin Description 10 Pin MSOP

Pin #	Name	Description
1	ASNS	PWM output of the triac dim decoder circuit. Outputs a 0 to 4V PWM signal with a duty cycle proportional to the triac dimmer on-time.
2	FLTR1	First filter input. The 120Hz PWM signal from ASNS is filtered to a DC signal and compared to a 1 to 3V, 5.85 kHz ramp to generate a higher frequency PWM signal with a duty cycle proportional to the triac dimmer firing angle. Pull above 4.9V (typical) to TRI-STATE® DIM.
3	DIM	Input/output dual function dim pin. This pin can be driven with an external PWM signal to dim the LEDs. It may also be used as an output signal and connected to the DIM pin of other LM3445 or LED drivers to dim multiple LED circuits simultaneously.
4	COFF	OFF time setting pin. A user set current and capacitor connected from the output to this pin sets the constant OFF time of the switching controller.
5	FLTR2	Second filter input. A capacitor tied to this pin filters the PWM dimming signal to supply a DC voltage to control the LED current. Could also be used as an analog dimming input.
6	GND	Circuit ground connection.
7	ISNS	LED current sense pin. Connect a resistor from main switching MOSFET source, ISNS to GND to set the maximum LED current.
8	GATE	Power MOSFET driver pin. This output provides the gate drive for the power switching MOSFET of the buck controller.
9	V _{CC}	Input voltage pin. This pin provides the power for the internal control circuitry and gate driver.
10	BLDR	Bleeder pin. Provides the input signal to the angle detect circuitry as well as a current path through a switched 230Ω resistor to ensure proper firing of the triac dimmer.

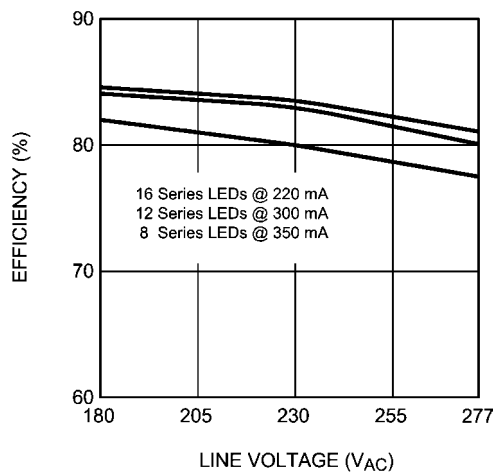

30103502

LM3445 Evaluation Board Schematic

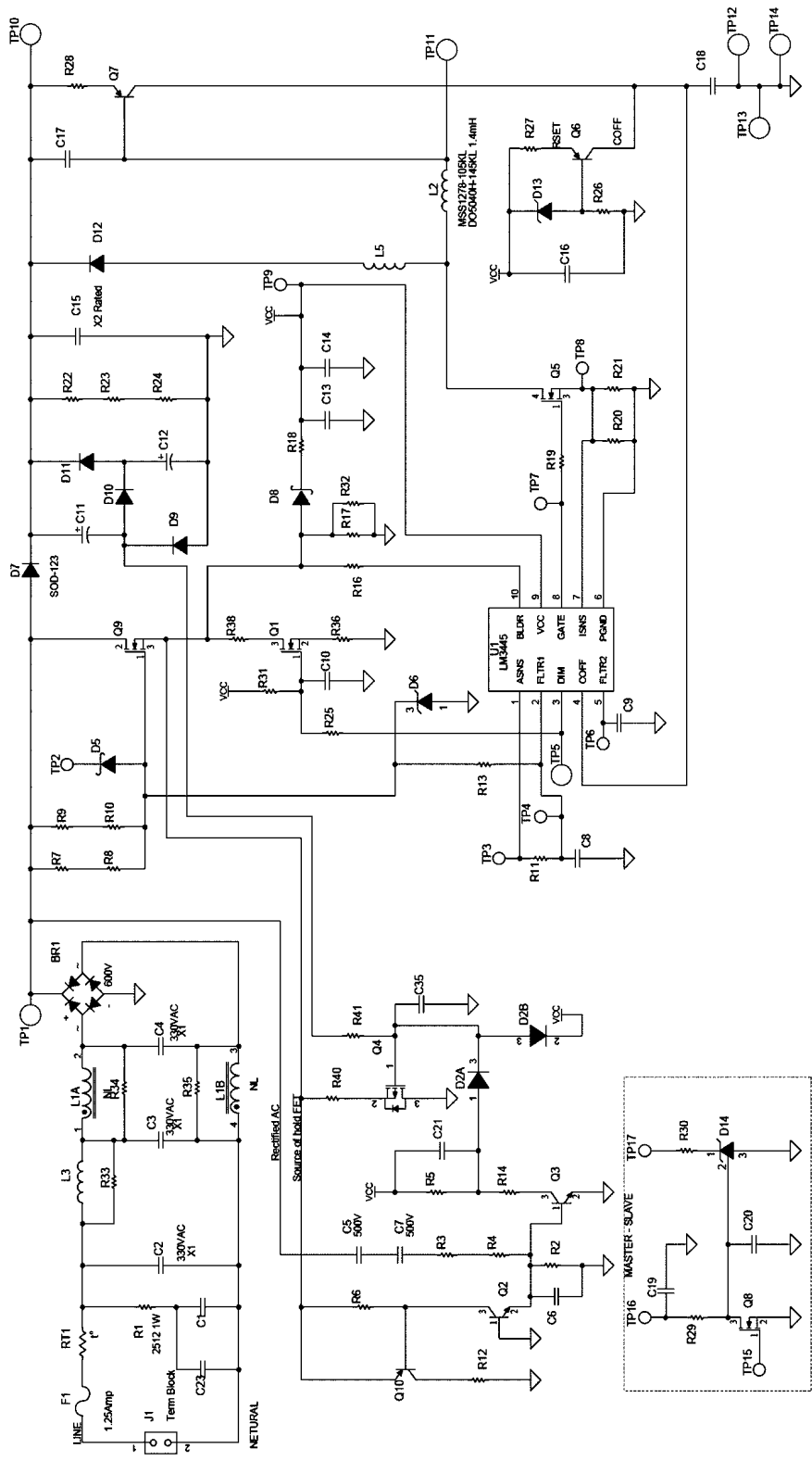

30103508

Bill of Materials LM3445 Evaluation Board

REF DES	Description	MFG	MFG Part Number
U1	IC Driver LED W/TRIAC DIM 10MSOP	National Semiconductor	LM3445MM/NOBP
BR1	Bridge Rectifier 600V 0.8A MINIDIP	Diodes Inc	HD06-T
C1	47 nF X7R 1206 10% 500V Ceramic	Vishay/Vitramon	VJ1206Y473KXEAT5Z
C2, C4	10 nF 330V _{AC} FILM	EPCOS Inc	B32911A3103M
C3, C23, C35	DNP		
C5, C7	1000 pF X7R 1206 500V Ceramic	AVX	399-3436-1-ND
C6	10 nF X7R 603 5% 100V Ceramic	AVX	06031C103JAT2A
C8	470 nF X7R 603 25V Ceramic	Murata	GRM188R71E474KA12D
C9, C16	100 nF X7R 603 25V Ceramic	Kemet	C0603C104K3RACTU
C10	220 nF X5R 603 25V Ceramic	AVX	06033D224KAT2A
C11, C12	22 uF ED-Radial 250V Electrolytic	Panasonic-ECG	EEU-ED2E220
C13, C14	22 uF X5R 1210 25V Ceramic	MuRata	GRM32ER61E226KE15L
C15	10 nF Film MK Series 305V _{AC}	EPCOS	B32921A2104M
C17	1 uF X7R 1206 100V Ceramic	Murata	GRM31CR72A105KA01L
C18	220 pF X7R 603 100V Ceramic	Yageo	CC0603KRX7R9BB221
C19	1 nF X7R 603 50V Ceramic	Kemet	C0603C102K5RACTU
C20	22 nF X7R 603 50V Ceramic	Kemet	C0603C223K5RACTU
C21	4.7 uF X5R 1206 10V Ceramic	TDK Corporation	C3216X7R1E475K
D2	Diode 70V SOT323 Dual	Fairchild	BAV99WT1G
D5, D8	Schottky 40V 120 mA SOD-123	NXP Semiconductor	BAS40H,115
D6	Zener 15V 350 mW SOT-23	Fairchild	BZX84C15
D7, D9, D10, D11	Diode GP 1A 1000V MINI-SMA	Comchip Technology	CGRM4007-G
D12	Diode 600V 2.2A TO-252	Cree	CSD01060E
D13	Zener 500 mW 5.6V SOD123	ON Semiconductor	MMSZ5V6T1G
D14	Shunt Regulator 0.5% SOT23	Zetex	ZTL431BFTA
F1	Fuse 1.25A 600V 3812 TELCOM SMP	Bel Fuse	SMP 1.25
J1	Terminal Block 2POS 5.08mm	Phoenix Contact	1715721
L1, MH1, MH2, MH3, MH4	DNP		
NEHDW1, R9, R10, R28, R32, R33	DNP		
L2	1.4 mH 10% DO5040H	Coilcraft	DO5040H-145KL
L3	1.0 mH 10% MSS1038	Coilcraft	MSS1038-105KL
L5	160Ω Impedance SMD Ferrite Chip	Steward	HI1206T161R-10
Q1, Q8	NMOS 100V 170 mA SOT-23	Fairchild	BSS123
Q2, Q3	NPN 60V 600 mA	Fair Child	MMBT4401
Q4	PMOS 50V 130 mA SOT-23	Fairchild Semiconductor	BSS84
Q5	NMOS 600V 3.9A DPAK	Fairchild	FCD4N60TM_WS
Q6	PNP 40V SOT-23	Fairchild	MMBT4403
Q7	PNP 300V 500 mA SOT-23	Fairchild	MMBTA92
Q9	NMOS 600V 4A D2PAK	STMicroelectronics	STB4NK60ZT4
Q10	PNP 30V 100 mA SOT23	ON Semiconductor	BC858CLT1G
R1	820Ω 1W 5% 2512 SMD	Vishay/Dale	CRCW2512820RJNEG
R2	7.5 kΩ 1%	Vishay-Dale	CRCW06037K50FKEA
R3, R4	100 kΩ 1% 1/4W	Rohm Semiconductor	MCR18EZPF1003
R5	20 kΩ 1%	Vishay-Dale	CRCW060320k0FKEA
R6	49.9 kΩ 1%	Vishay-Dale	CRCW080549K9FKEA
R7, R8	200 kΩ 1% 1/4W	Vishay-Dale	CRCW1206200KFKEA

R11	280 k Ω 1%	Vishay/Dale	CRCW0603280KFKEA
R12	249 Ω 1%	Vishay-Dale	CRCW0805249RFKEA
R13	3.3 M Ω 1%	Vishay/Dale	CRCW08053M30FKEA
R14	100 Ω 1%	Vishay-Dale	CRCW1206100RFKEA
R40	150 Ω 1%	Vishay-Dale	CRCW1206150RFKEA
R16	0 Ω 5%	Vishay/Dale	CRCW06030000Z0EA
R17	100k Ω 1% 1/4W	Rohm Semiconductor	MCR18EZHf1003
R18, R34, R35	0 Ω 1/4W	Vishay/Dale	CRCW12060000Z0EA
R19	4.7 Ω 1%	Vishay/Dale	CRCW08054R70FNEA
R20	10 Ω 1% 1/4W	Vishay/Dale	541-10.0FCT-ND
R21	1.8 Ω 5% 1/3W	Vishay/Dale	CRCW12101R80JNEA
R22, R23, R24	1 M Ω 1% 1/4W	Vishay/Dale	CRCW12061M00FKEA
R25	49.9 k Ω 1%	Panasonic - ECG	ERJ-3EKF4992V
R26, R29	33.2 k Ω 1%	Vishay/Dale	CRCW060333K2FKEA
R27	221 k Ω 1%	Vishay/Dale	CRCW0603221KFKEA
R30	2 k Ω 1%	Vishay/Dale	CRCW06032K00FKEA
R31	402 k Ω 1%	Vishay-Dale	CRCW0603402KFKEA
R36	150 Ω 1%	Vishay-Dale	CRCW0805150RFKEA
R38	249 Ω 1% 1/4W	Vishay-Dale	CRCW1206249RFKEA
R41	402 k Ω 1%	Rohm Semiconductor	MCR18EZHf4023
RT1	Inrush Limiter 80 Ω 20%	Cantherm	MF72-080D9
TP1, TP5, TP10, TP11, TP12, TP13, TP14	Terminal DBL Turret 0.109"L Brass	Keystone Electronics	1502-2

PCB Layout

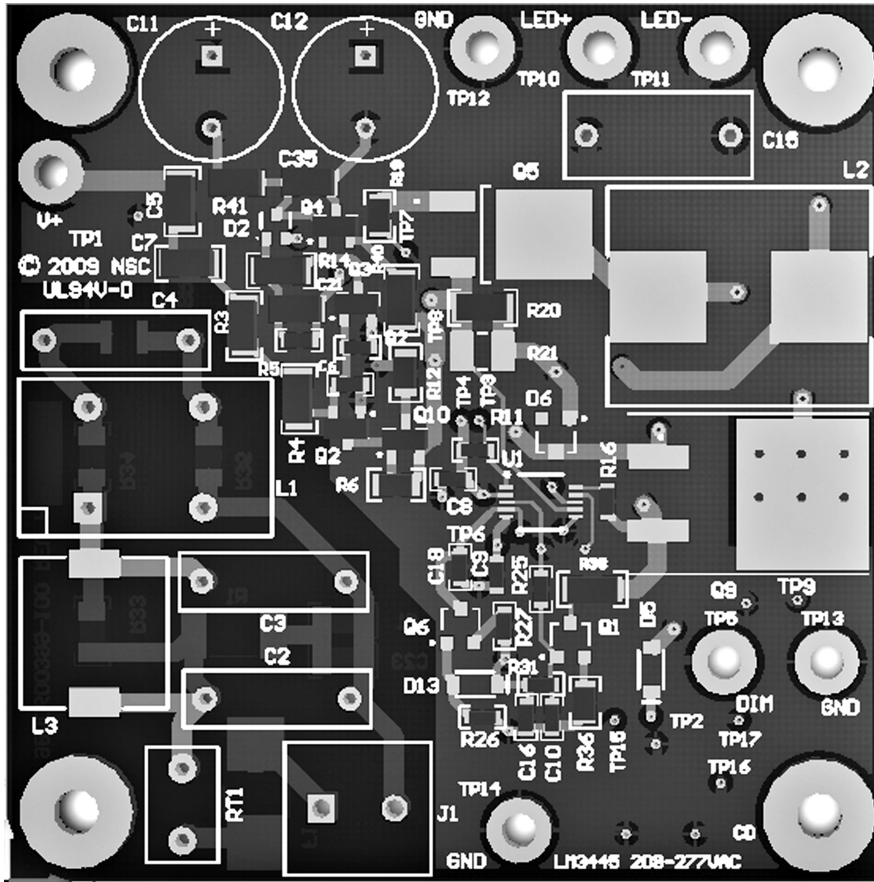

Top Layer

30103511

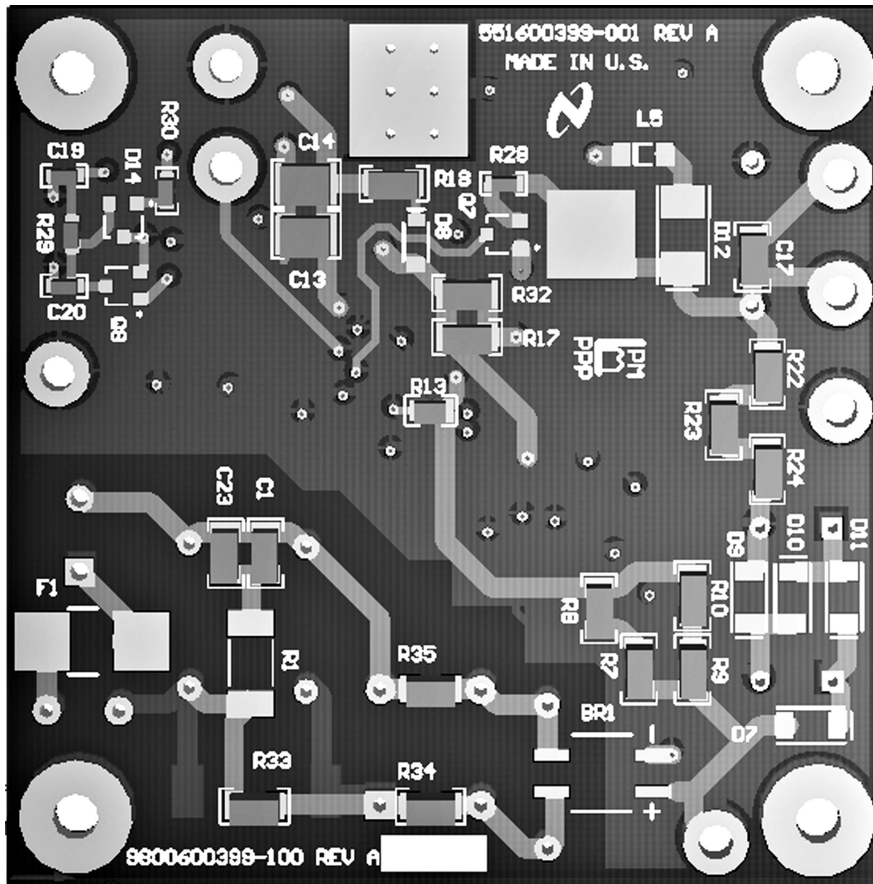

Bottom Layer

30103509

Warning: The LM3445 evaluation boards have no isolation or any type of protection from shock. Caution must be taken when handling evaluation board. Avoid touching evaluation board, and removing any cables while evaluation board is operating. Isolating the evaluation board rather than the oscilloscope is highly recommended.

Design Customization Procedure

The LM3445 datasheet outlines a typical implementation and design procedure for a LM3445 based triac-dimmable LED driver. One feature includes the use of a PNP transistor to translate the LED string voltage and maintain a constant off time. This allows a constant LED current to be maintained regardless of the number of series LEDs. For input voltages above 150V_{AC} a suitable PNP transistor becomes difficult to find. An alternate implementation uses a current source to supply a constant current to charge the off-time capacitor. This circuit has been implemented on this demonstration board and is described below:

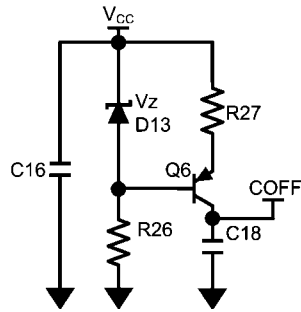

30103512

This method eliminates the need for the LED voltage translation transistor but requires adjustment to the circuit values when a different LED string voltage is required and it is desired to keep the LED string average current the same. Sample calculations illustrating the design procedure are shown below:

SPECIFICATIONS

Number of LEDs, N = 8

$$V_{LED} = 3.4V \cdot N$$

$$V_{IN} = 230V_{AC}$$

$$f_{SW} \text{ target} = 80 \text{ kHz}$$

$$V_{FLTR2} = 750 \text{ mV}$$

$$\Delta i = 310 \text{ mA}$$

$$\text{Efficiency Estimate, } n = 0.75$$

$$I_{ave} = 350 \text{ mA}$$

$$V_Z = 5.6 \text{ V}$$

$$V_{BE} = 0.5 \text{ V}$$

$$C18 = 220 \text{ pF}$$

1. Inductor Selection

Based on the design parameters above, calculate the target inductor value:

$$L = \frac{V_{LED} \left(1 - \left(\frac{1}{n} \cdot \frac{V_{LED}}{V_{BUCK}} \right) \right)}{\Delta i \cdot f_{sw}}$$

$$= \frac{(8 \times 3.4) \left(1 - \left(\frac{1}{0.75} \cdot \frac{8 \times 3.4}{230 \times \sqrt{2}} \right) \right)}{0.31 \cdot 80k}$$

$$= 974 \mu\text{H}$$

Select 1mH

2. Current Source Component Selection

Calculate t_{OFF} to obtain the target inductor ripple current using the additional target parameters we defined:

$$t_{off} = \frac{\Delta i \cdot L}{V_{LED}}$$

$$= \frac{0.31A \times 1 \text{ mH}}{8 \times 3.4V}$$

$$= 11.4 \mu\text{s}$$

Using the target t_{OFF} result the current source output can be calculated using:

$$I_s = \frac{C18 \cdot 1.276}{t_{off}}$$

$$= \frac{220 \text{ pF} \times 1.276}{11.4 \mu\text{s}}$$

$$= 24.6 \mu\text{A}$$

Finally, R27 can be selected using the current, Zener voltage, and transistor parameters:

$$R27 = \frac{(V_Z - V_{BE})}{I_s}$$

$$= \frac{(5.6V - 0.5V)}{24.6 \mu\text{A}}$$

$$= 207 \text{ k}\Omega, \text{ select } 221 \text{ k}\Omega$$

3. Average LED Current

The LM3445 constant off-time control loop regulates the peak inductor and therefore, peak LED current. The average LED current is related to the peak inductor current by the following relationship:

$$i_{pk} = I_{ave} + \frac{\Delta i}{2}$$

$$= 0.35 + \frac{0.31}{2}$$

$$= 505 \text{ mA}$$

Now that our current source and peak current are defined we can adjust the peak current detect level to obtain the desired average output current .

On this demo board the current sense resistors are the parallel combination of R20 and R21, equal to R_{sense} :

$$R_{sense} = \frac{750 \text{ mV}}{i_{pk}}$$

$$= \frac{750 \text{ mV}}{505 \text{ mA}}$$

$$= 1.48 \Omega$$

A 10 Ω and 1.8 Ω are selected as R20 and R21 for a net resistance of 1.52 Ω

4. Holding Current

This LM3445 High Voltage demo board includes five circuit blocks (shown below) that work together to draw additional current from the line at key points in the dimming cycle and ensure a minimum level of current is drawn from the triac dimmer at all times. A description of their operation is outlined below. References are made to Q1 and D9 which can be found on page 3 schematic.

- Triac edge detect circuit:** When the triac fires a sharp edge is created that can be captured by a properly sized R-C circuit. The combination of C5/C7 and R3/R4 create a negative pulse on R2 for a reverse phase dimmer or a positive pulse on R2 for a forward phase dimmer. The pulse polarity determines which subsequent block will use the signal.
- Forward phase detect/Valley Fill Enable and Valley Fill triac holding current circuit:** With Q3 turning on with each rectified AC edge from a forward phase dimmer, a duty cycle divider is created that adjusts the voltage at the anode of D2A. With the values implemented, the result is an average of $\sim 2V$ at the anode of D2A when the rising edge is present on R2 allowing the gate voltage of Q4 to rise and fall with the valley fill diode cathode voltage V_{VF} (V_{VF} is connected to the cathode of D9) and turn Q4 on while the valley fill circuit is providing power to the load. Additional loading at this time is important because as the valley fill capacitors are providing current to the load, no current is being provided by the input through the triac and a condition for triac mis-fire would otherwise be created. When a fast rising edge is not present, Q3 will remain

off and the D2A anode voltage and Q4 gate will rise to V_{CC} and ensure Q4 will not turn on. The final piece of the circuit is D2B. The cathode of D9 can rise to $\frac{1}{2}V_{in}$ while the valley fill capacitors are charging. Since the Q4 gate is rated at ± 20 volts a diode is added from the gate to V_{CC} clamping this point at a diode drop above V_{CC} . When using a reverse phase dimmer the waveform edge rises with the line frequency requiring $\sim 4ms$ to reach the peak. This is not a fast enough edge to create a signal at the base of Q3 meaning this circuit will naturally not operate when using a reverse phase dimmer or when no dimmer is present.

- Linear R_{HOLD} Insertion circuit :** Adds holding current as LEDs are dimmed to 50% or lower. A variable voltage between 0 and 5 volts is generated at the Q1 gate by averaging the DIM pin 5.9kHz square wave. The DIM pin, normally an input, is used as an output in this implementation as it outputs a square wave with a duty cycle that varies with triac firing angle. As the LEDs are dimmed, the voltage at the Q1 gate will rise pulling a current equal to the Q1 source voltage divided by R36.

- Reverse phase holding current circuit:** Adds holding current when a reverse phase triac edge is detected. The triac edge detect R-C creates a negative pulse on the emitter of Q2 each cycle a reverse phase dimmer is present and dimming. This turns on Q10 and connects R12 to the Q9 pass FET adding holding current and sharpening the turn-off of the reverse phase dimmer.

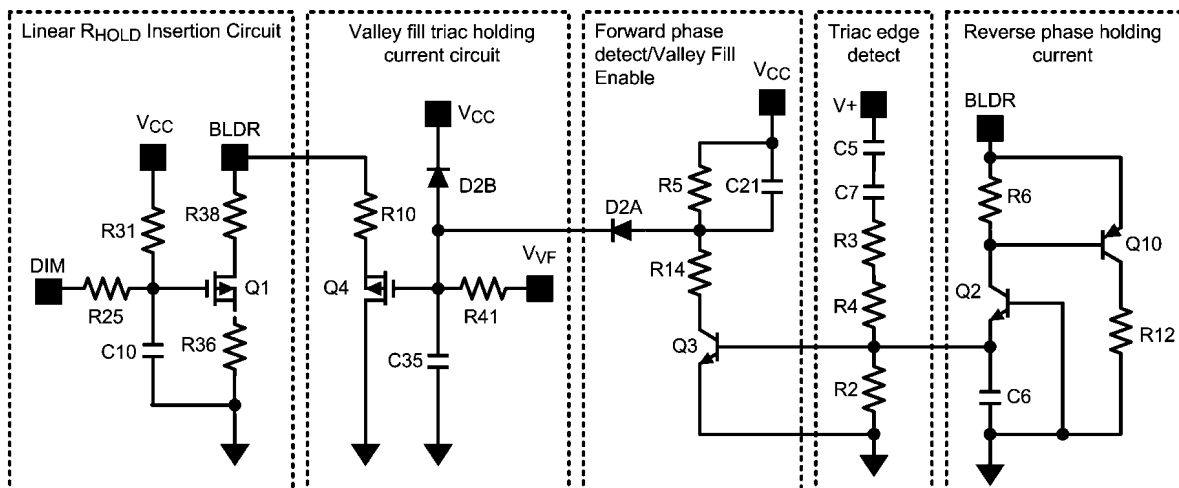

30103521

5. Output Variation without Component Adjustment

If the variation of converter operating parameters is not a concern, the number of LEDs can be adjusted without changes to the evaluation board component values. The effects of changing the LED string voltage without adjustment of the values can be seen below. This can also be used as a guide to understand the variation that will be seen if the LED string voltage does change during operation. With the present design the net change was approximately 18.7 mA and 1.35 kHz per LED or approximately 5.5 mA and 400Hz per volt.

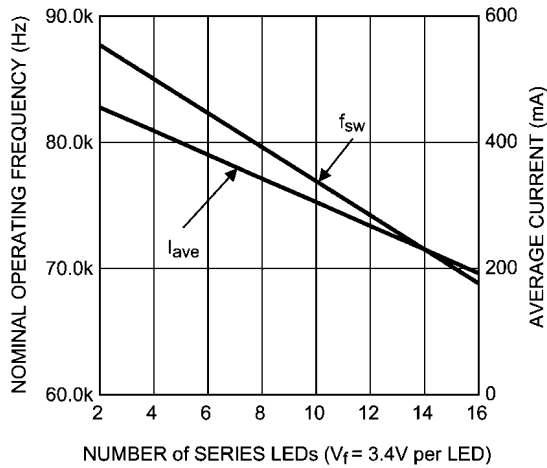

30103520

If variation due to a change in string voltage is a concern, these effects can be minimized by increasing the inductance value and/or raising the switching frequency.

A larger inductance reduces the peak-to-peak ripple current. If made large enough it will become the dominant parameter effecting the peak-to-peak ripple current. If the peak-to-peak ripple current variation can be minimized, so will the average output current.

6. Thermal Limitation

All triac holding current is drawn through the stand-off FET Q9. At approximately 50% dimming (90° firing angle) the power dissipation in Q9 is at its maximum.

If it is desired to dim for an extended period at this operating point the input voltage should be limited to a maximum of $240V_{AC}$.

Notes

AN-1995

Notes

For more National Semiconductor product information and proven design tools, visit the following Web sites at:

Products		Design Support	
Amplifiers	www.national.com/amplifiers	WEBENCH® Tools	www.national.com/webench
Audio	www.national.com/audio	App Notes	www.national.com/appnotes
Clock and Timing	www.national.com/timing	Reference Designs	www.national.com/refdesigns
Data Converters	www.national.com/adc	Samples	www.national.com/samples
Interface	www.national.com/interface	Eval Boards	www.national.com/evalboards
LVDS	www.national.com/lvds	Packaging	www.national.com/packaging
Power Management	www.national.com/power	Green Compliance	www.national.com/quality/green
Switching Regulators	www.national.com/switchers	Distributors	www.national.com/contacts
LDOs	www.national.com/ldo	Quality and Reliability	www.national.com/quality
LED Lighting	www.national.com/led	Feedback/Support	www.national.com/feedback
Voltage Reference	www.national.com/vref	Design Made Easy	www.national.com/easy
PowerWise® Solutions	www.national.com/powerwise	Solutions	www.national.com/solutions
Serial Digital Interface (SDI)	www.national.com/sdi	Mil/Aero	www.national.com/milaero
Temperature Sensors	www.national.com/tempensors	SolarMagic™	www.national.com/solarmagic
Wireless (PLL/VCO)	www.national.com/wireless	PowerWise® Design University	www.national.com/training

THE CONTENTS OF THIS DOCUMENT ARE PROVIDED IN CONNECTION WITH NATIONAL SEMICONDUCTOR CORPORATION ("NATIONAL") PRODUCTS. NATIONAL MAKES NO REPRESENTATIONS OR WARRANTIES WITH RESPECT TO THE ACCURACY OR COMPLETENESS OF THE CONTENTS OF THIS PUBLICATION AND RESERVES THE RIGHT TO MAKE CHANGES TO SPECIFICATIONS AND PRODUCT DESCRIPTIONS AT ANY TIME WITHOUT NOTICE. NO LICENSE, WHETHER EXPRESS, IMPLIED, ARISING BY ESTOPPEL OR OTHERWISE, TO ANY INTELLECTUAL PROPERTY RIGHTS IS GRANTED BY THIS DOCUMENT.

TESTING AND OTHER QUALITY CONTROLS ARE USED TO THE EXTENT NATIONAL DEEMS NECESSARY TO SUPPORT NATIONAL'S PRODUCT WARRANTY. EXCEPT WHERE MANDATED BY GOVERNMENT REQUIREMENTS, TESTING OF ALL PARAMETERS OF EACH PRODUCT IS NOT NECESSARILY PERFORMED. NATIONAL ASSUMES NO LIABILITY FOR APPLICATIONS ASSISTANCE OR BUYER PRODUCT DESIGN. BUYERS ARE RESPONSIBLE FOR THEIR PRODUCTS AND APPLICATIONS USING NATIONAL COMPONENTS. PRIOR TO USING OR DISTRIBUTING ANY PRODUCTS THAT INCLUDE NATIONAL COMPONENTS, BUYERS SHOULD PROVIDE ADEQUATE DESIGN, TESTING AND OPERATING SAFEGUARDS.

EXCEPT AS PROVIDED IN NATIONAL'S TERMS AND CONDITIONS OF SALE FOR SUCH PRODUCTS, NATIONAL ASSUMES NO LIABILITY WHATSOEVER, AND NATIONAL DISCLAIMS ANY EXPRESS OR IMPLIED WARRANTY RELATING TO THE SALE AND/OR USE OF NATIONAL PRODUCTS INCLUDING LIABILITY OR WARRANTIES RELATING TO FITNESS FOR A PARTICULAR PURPOSE, MERCHANTABILITY, OR INFRINGEMENT OF ANY PATENT, COPYRIGHT OR OTHER INTELLECTUAL PROPERTY RIGHT.

LIFE SUPPORT POLICY

NATIONAL'S PRODUCTS ARE NOT AUTHORIZED FOR USE AS CRITICAL COMPONENTS IN LIFE SUPPORT DEVICES OR SYSTEMS WITHOUT THE EXPRESS PRIOR WRITTEN APPROVAL OF THE CHIEF EXECUTIVE OFFICER AND GENERAL COUNSEL OF NATIONAL SEMICONDUCTOR CORPORATION. As used herein:

Life support devices or systems are devices which (a) are intended for surgical implant into the body, or (b) support or sustain life and whose failure to perform when properly used in accordance with instructions for use provided in the labeling can be reasonably expected to result in a significant injury to the user. A critical component is any component in a life support device or system whose failure to perform can be reasonably expected to cause the failure of the life support device or system or to affect its safety or effectiveness.

National Semiconductor and the National Semiconductor logo are registered trademarks of National Semiconductor Corporation. All other brand or product names may be trademarks or registered trademarks of their respective holders.

Copyright© 2009 National Semiconductor Corporation

For the most current product information visit us at www.national.com



National Semiconductor Americas Technical Support Center
Email: support@nsc.com
Tel: 1-800-272-9959

National Semiconductor Europe Technical Support Center
Email: europe.support@nsc.com

National Semiconductor Asia Pacific Technical Support Center
Email: ap.support@nsc.com

National Semiconductor Japan Technical Support Center
Email: jpn.feedback@nsc.com