

LM3407 Evaluation Board Reference Design

National Semiconductor
 Application Note 1763
 SH Wong
 January 21, 2009



Introduction

The LM3407 is a Pulse-Width-Modulation (PWM) floating buck converter with an integrated N-channel power MOSFET designed to provide precision constant current output for driving high power LEDs, such as the Lumileds Luxeon® power LEDs and OSRAM Golden DRAGON® LEDs. The switching frequency is selectable between 300 kHz and 1 MHz by changing the value of the frequency setting resistor, allowing for the use of small external components. The LM3407 features a Pulse Level Modulation (PLM) control scheme which ensures the accuracy of the constant current output well within 10% over input voltage and operating temperature ranges

with an external 1% thick film current setting resistor. The converter features a DIM pin which accepts standard logic pulses for controlling the brightness of the LED array, making the LM3407 ideal for use as a precision power LED driver or constant current source.

This application note introduces the design of a sample circuit with the LM3407 providing 350 mA constant current to drive an LED array of 6 high power LEDs connected in series. The board can accept an input voltage ranging from 22V to 30V. The schematic, PCB layout, bill of materials, and circuit design criteria are shown in detail. Typical performance and operating waveforms are also provided for reference.

Evaluation Board Schematic

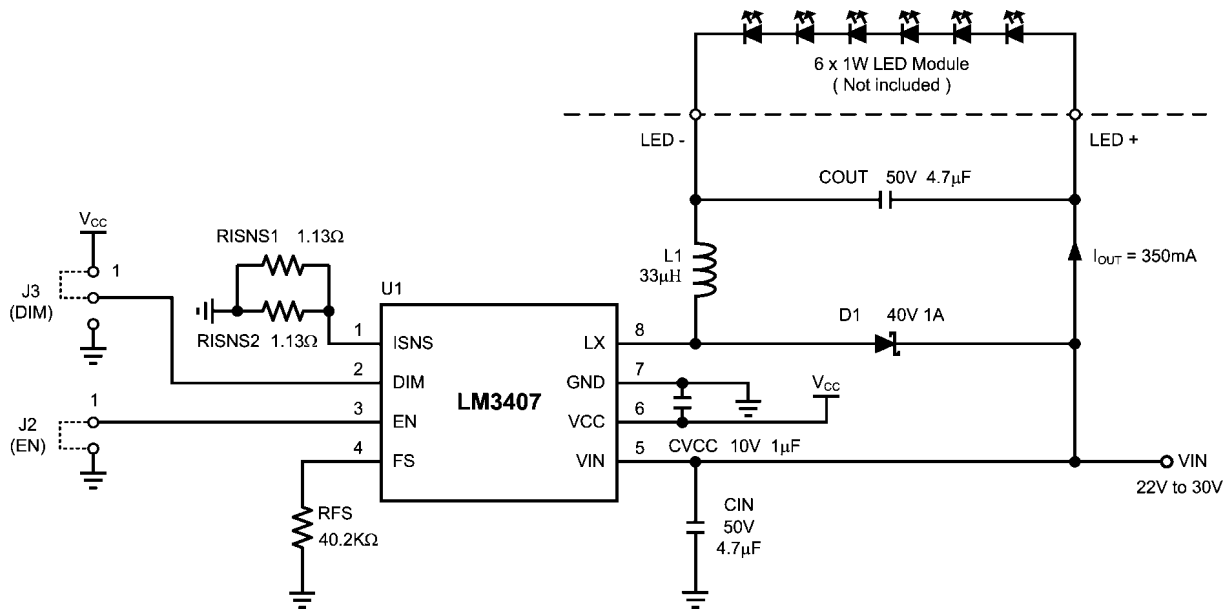

30046701

FIGURE 1. LM3407 Evaluation Board Schematic

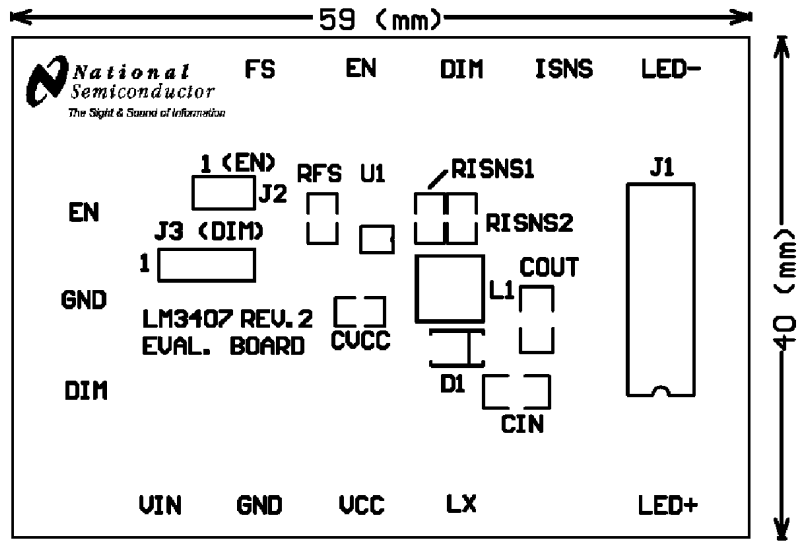

30046702

FIGURE 2. LM3407 Evaluation Board PCB Top Overlay

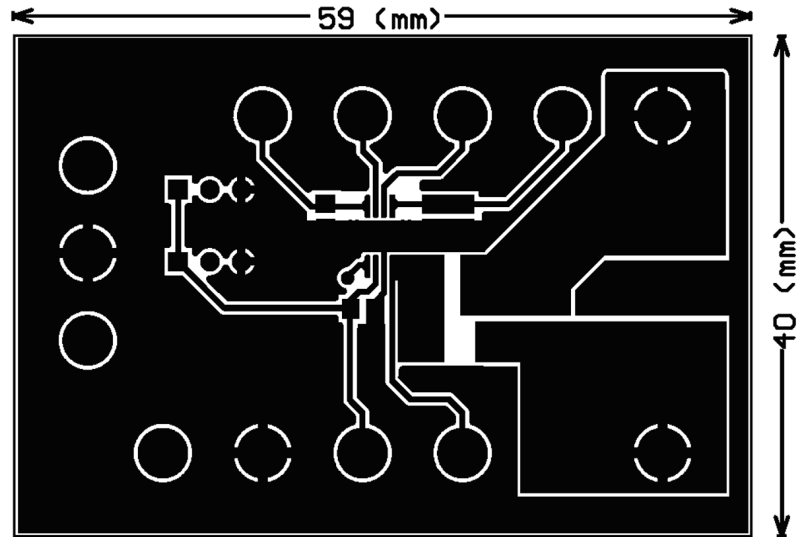

30046703

FIGURE 3. LM3407 Evaluation Board PCB Top View

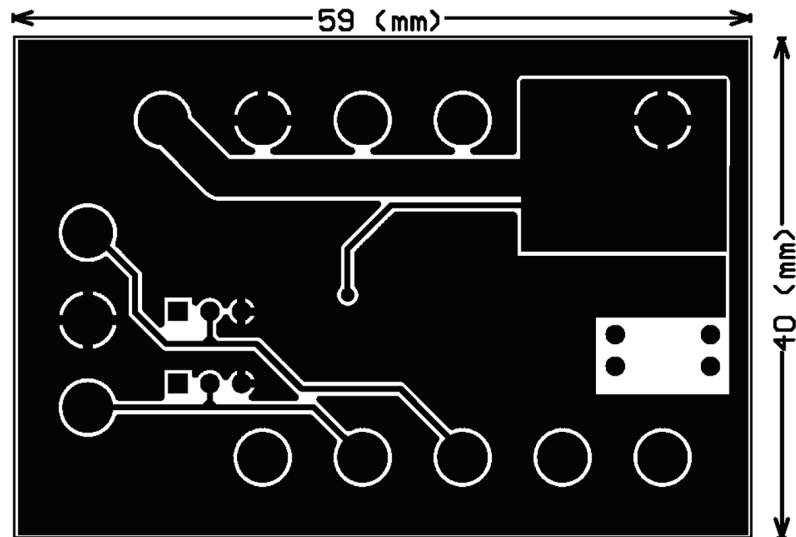

FIGURE 4. LM3407 Evaluation Board PCB Bottom View

Evaluation Board Quick Setup Procedures

Step	Procedure	Notes
1	Remove all jumpers on the evaluation board.	
2	Connect the LED array of 6 power LEDs to J1.	
3	Connect Power Supply output to the VIN terminal of the evaluation board.	
4	Set the power supply output voltage to 24V.	V_{IN} should not exceed 30V
6	Check the voltage of the VCC terminal of the board.	$V_{CC} = 4.5V \pm 8\%$
7	Short pin 1 and 2 of J3 by using a jumper.	LEDs fully turned ON
8	Check the LED current (I_{OUT}) by using an ammeter.	$I_{OUT} = 350mA \pm 6\%$
9	Short J2 by using a jumper to check the shutdown function.	$I_{OUT} = 0$

Evaluation Board Performance Characteristic

Description	Symbol	Condition	Min	Typ	Max	Unit
Input Voltage	V_{IN}		22	24	30	V
Output Current	I_{OUT}	DIM pin connected to VCC	330	350	370	mA
Output Current Variation	$ \Delta I_{OUT} $	All V_{IN} and I_{OUT} Conditions			6	%
Efficiency		No. of LED = 6	93		96	%
		No. of LED = 4	90		95	%
		No. of LED = 2	85		92	%

Design Procedure

CONNECTING TO LED ARRAY

The LM3407 evaluation board features a female 6-pin SIP connector J1 for board-to-board connection of the LED array. Figure 5 shows the pin-out of J1. To avoid damaging the

components, do not connect the LED array with incorrect polarity or alter the connections of the LED array when the evaluation board is connected to power. It is highly recommended to attach the LED array to a heat sink for heat dissipation and to apply force ventilation to the LED array as necessary.

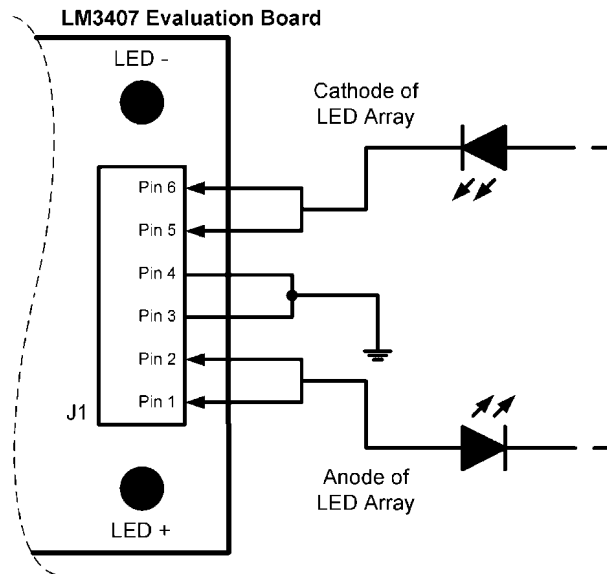

30046705

FIGURE 5. Connecting an LED Array to the LM3407 Evaluation Board

SETTING THE LED CURRENT

The output current of the evaluation board is adjustable by changing the current setting resistors RISNS1 and RISNS2. By default, the value of both RISNS1 and RISNS2 is 1.13 Ω at 1% tolerance, which results in a resistance of 0.565 Ω . This value of R_{ISNS} sets the output current (I_{OUT}) at 350 mA. The value of R_{ISNS} can be calculated by using the equation:

$$R_{ISNS} = \frac{0.198V}{I_{OUT}}$$

When selecting the value of the current setting resistors (RISNS1 and RISNS2), it is important to ensure the rated powers of the resistors are not exceeded. For example, when I_{OUT} is set at 350mA, the total power dissipation on RISNS1 and RISNS2 in steady state is 0.35 mA² x 0.565 Ω , which equals 69 mW, indicating a resistor of 1/8W power rating is appropriate.

SETTING THE SWITCHING FREQUENCY

The switching frequency of the LM3407 evaluation board is programmable by adjusting the value of the frequency setting resistor RFS. The default value of the RFS pre-installed on the evaluation board is 40.2 k Ω , at which the switching frequency is 1MHz. In order to guarantee good current regulation, it is suggested to set the switching frequency between 300kHz and 1MHz. The switching frequency is calculated by the expression shown below:

$$f_{sw} = \frac{40 \text{ Meg}}{R_{FS}} + 40 \text{ in kHz}$$

for 40k Ω \leq RFS \leq 150 k Ω

For the convenience of selecting the value of RFS, a selection chart of f_{sw} against RFS is provided:

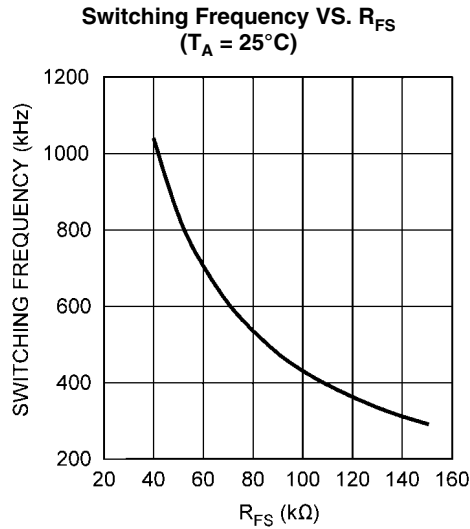

30046707

The LM3407 is internally compensated and requires no external components for feedback compensation. The components of this evaluation board are optimized for driving 6 power LEDs with the input voltage between 22V and 30V. If different conversions are required, such as changes to input voltage and loading conditions, L1 and RFS may need to be changed to ensure stable operation.

SELECTION OF INDUCTOR AND DIODE

In order to achieve accurate constant current output, the LM3407 is required to operate in Continuous Conduction Mode (CCM) under all operating conditions. In general, the magnitude of the inductor ripple current should be kept as small as possible. If the PCB size is not limited, higher inductance values result in better accuracy of the output current. However, in order to minimize the physical size of the circuit, an inductor with minimum physical outline should be selected such that the converter always operates in CCM and the peak inductor current does not exceed the saturation current limit of the inductor. The ripple and peak current of the inductor can be calculated as follows:

Peak to Peak Inductor Ripple Current:

$$I_{L(ripple)} = \frac{\left[V_{IN} - (n \times V_F) - 0.198 \left(1 + \frac{1}{R_{ISNS}} \right) \right] \times (n \times V_F)}{L \times V_{IN} \times f_{SW}}$$

Peak Inductor Current:

$$I_{L(peak)} = \frac{0.198}{R_{ISNS}} + \frac{I_{L(ripple)}}{2}$$

where n is the number of LEDs in a string and V_F is the forward voltage of one LED.

The minimum inductance required for the specific application can be calculated by:

$$L_{min} = \frac{\left[V_{IN} - (n \times V_F) - 0.198 \times \left(1 + \frac{1}{R_{ISNS}} \right) \right] \times (R_{ISNS} \times n \times V_F)}{0.197 \times V_{IN} \times f_{SW}}$$

Since the evaluation board is designed to drive a LED array of 6 LEDs, the default value of the inductor is 33μH to ensure CCM operation for the input voltage between 22V and 30V with 1MHz switching frequency. For the applications with different input voltage or number of LEDs, the inductance of the inductor may have to be changed to maintain accurate output current. Table 1 shows the suggested inductance of the inductor for 500kHz and 1MHz switching frequency.

The output diode of the evaluation board circuit is selected depending on the output voltage and current. The diode must have a rated reverse voltage higher than the input voltage of the regulator and the peak current rating must be higher than the expected maximum inductor current. Using a schottky diode with low forward voltage will decrease power dissipation and increase conversion efficiency.

TABLE 1. Suggested Inductance Value of the Inductor

Inductor selection table for $f_{SW} = 500 \text{ kHz}$, $C_{OUT} = 4.7 \mu\text{F}$ (1 μF for 1 LED)

VIN/V	Number of LED						
	1	2	3	4	5	6	7
5	22 μH						
10	22 μH	22 μH					
15	22 μH	22 μH	22 μH				
20	22 μH	33 μH	22 μH	22 μH	22 μH		
25	22 μH	33 μH	33 μH	22 μH	22 μH	22 μH	
30	22 μH	47 μH	33 μH	33 μH	33 μH	22 μH	22 μH

Inductor selection table for $f_{SW} = 1 \text{ MHz}$, $C_{OUT} = 4.7 \mu\text{F}$ (1 μF for 1 LED)

5	22 μH						
10	22 μH	22 μH					
15	22 μH	22 μH	22 μH				
20	22 μH	22 μH	22 μH	22 μH	22 μH		
25	22 μH	22 μH	22 μH	22 μH	22 μH	22 μH	
30	22 μH	33 μH	22 μH	22 μH	22 μH	22 μH	22 μH

LED DIMMING

There are two ways to disable the current output (I_{OUT}) of the evaluation board circuit. The current output of the LM3407 evaluation board can be disabled by connecting either the DIM or EN pin to ground. Connecting the EN pin to ground will shutdown the internal linear regulator and maintain minimal power consumption. Connecting the DIM pin to ground will only disable the current output of the LM3407, while the internal oscillator and control circuits remain active to facilitate fast wake up.

In general, dimming of the LED array can be achieved by applying a logic pulse chain to the DIM terminal of the evaluation board to periodically enable and disable the LM3407 and control the average I_{OUT} of the LED array. Since the color characteristics of a LED are closely related to the driving current, dimming by adjusting the current setting resistor causes the color temperature to drift. To control the brightness of the LED array effectively, PWM dimming should be used. PWM dimming is a dimming method which controls the ON/OFF time ratio of the LED(s) at fixed frequency.

The DIM terminal on the evaluation board is directly connected to the DIM pin of the LM3407, which provides a PWM signal input for dimming of the LED array. In order to properly enable and disable the LM3407, the PWM dimming signal

should have a logic low of 1V maximum and logic high of 2V minimum. The DIM terminal is internally pulled down to ground by a 400 k Ω resistor, which should be connected to either logic high or low and should not be left open. In steady state, the expression of the average LED driving current is:

$$I_{OUT(AVG)} = D_{DIM} \times \frac{0.198}{R_{ISNS}}$$

LIMITS OF PWM DIMMING

The maximum PWM dimming frequency, minimum duty cycle, and maximum duty cycle are shown in Figure 6. The maximum dimming frequency should not exceed 1/50 of the switching frequency f_{SW} of the LM3407. To avoid visible flicker, dimming frequencies lower than 100 Hz are not recommended. In Figure 6, T is the period of the PWM dimming signal. The interval t_D represents the time delay from a logic high of the dimming signal and the onset of the output current. t_{SU} and t_{SD} are the time needed for the output current to slew up from zero to steady state and slew down to zero respectively. In the figure, it can be seen that the minimum duty cycle of the dimming signal should not be shorter than the sum of t_{SU} and t_{SD} of the output current.

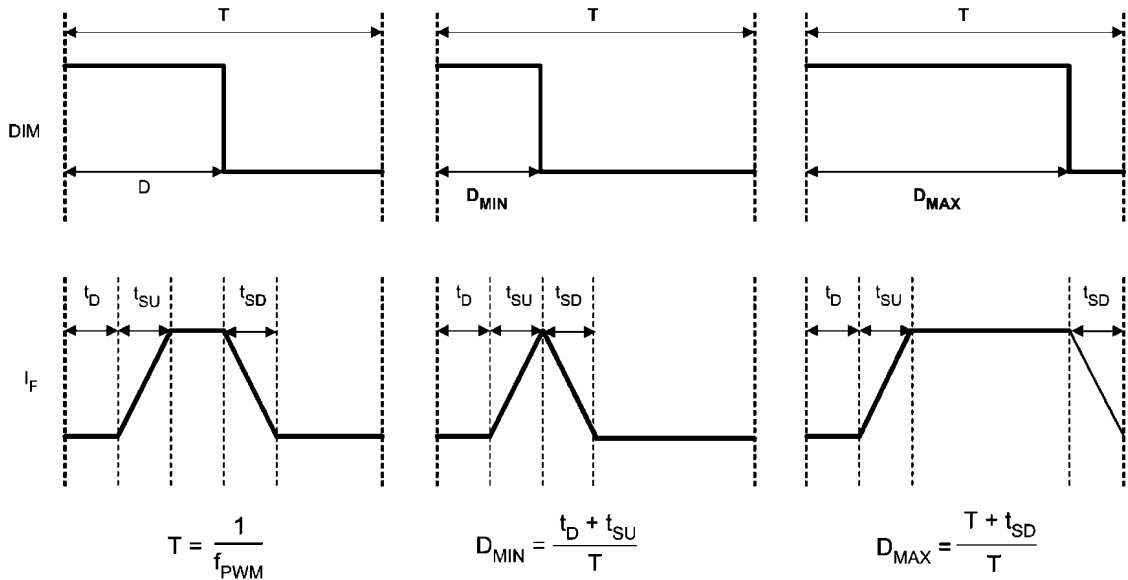

30046712

FIGURE 6. Limits of the PWM Dimming Signal

PCB LAYOUT GUIDE

Since copper traces of PCBs carry resistance and parasitic inductance, the longer the copper trace, the higher the resistance and inductance. These factors introduce voltage and current spikes to the switching nodes and impair the performance of the whole circuit. To optimize the performance of the LM3407, the rule of thumb is to keep the connections between components as short and direct as possible. Since true average current regulation is achieved by detecting the average switch current, the current setting resistors RISNS1 and RISNS2 must be located as close to the LM3407 as possible to reduce the parasitic inductance of the copper trace and avoid noise pick-up. The connections between LX pin, rectifier

D1, inductor L1 and output capacitor COUT should be kept as short as possible to reduce the voltage spikes at the LX pin. CVCC is the output filter capacitor for the internal linear regulator of the LM3407, it is recommended to be placed close to the pin VCC. The input filter capacitor CIN should be located close to L1 and the cathode of D1. If CIN is connected to the VIN pin by a long trace, a 0.1 μ F capacitor should be added close to pin VIN for noise filtering. In normal operation, heat will be generated inside the LM3407 and may damage the device if no thermal management is applied. For more detail on switching power supply layout considerations see Application Note AN-1149: Layout Guidelines for Switching Power Supplies.

Bill of Materials

Designation	Description	Package	Manufacture Part #	Vendor
U1	LED Driver IC, LM3407	eMSOP-8	LM3407	NSC
L1	Inductor 33 μ H 0.58A	4.0 x 4.0 x 1.8 (mm)	LPS4018-333ML	Coilcraft
	* Inductor 33 μ H 0.56A	4.8 x 4.3 x 3.5 (mm)	CR43NP-330K	Sumida
D1	Schottky Diode 40V 1.0A	DO-214AC (SMA)	SS14	Vishay
CIN, COUT	Cap MLCC 50V 4.7 μ F X7R	1210	GRM32ER71H475K88L	Murata
CVCC	Cap MLCC 10V 1.0 μ F X5R	0805	GRM188R61A105KA61D	Murata
RISNS1, RISNS2	Chip Resistor 1.13 Ω 1%	0805	CRCW08051R13F	Vishay
RFS	Chip Resistor 40.2k Ω 1%	0805	CRCW08054022F	Vishay
J1	6-pin Connector	DIP-12	535676-5	Tyco Electronics
J2	2-way Jumper System	2.54 (mm) Pitch		
J3	3-way Jumper System	2.54 (mm) Pitch		
VCC, GND, EN, DIM, ISNS, LX	Terminal pin	2.29 (mm) Dia.	160-1026	Cambion
VIN, GND	Terminal pin	1.57 (mm) Dia.	160-1512	Cambion
PCB	LM3407 Evaluation Board	59 x 40 (mm)		NSC
J3	2-pin Jumper			

*Alternative Supplier

Typical Performance and Waveforms

All curves and waveforms taken at $T_A = 25^\circ\text{C}$ unless otherwise specified.

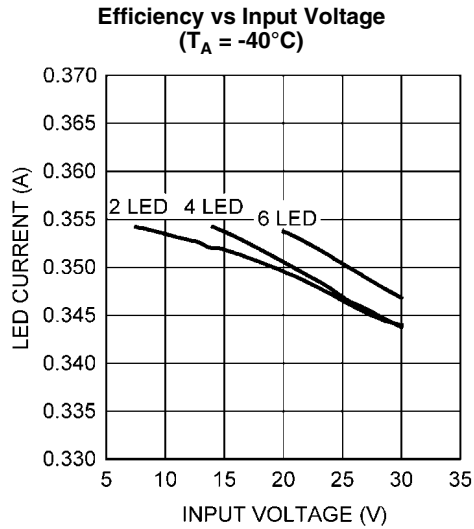

30046713

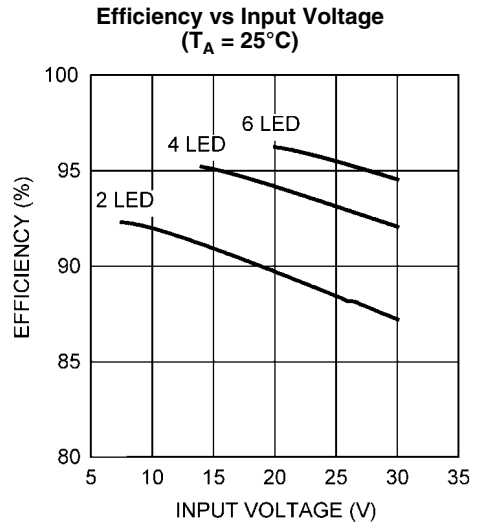

30046714

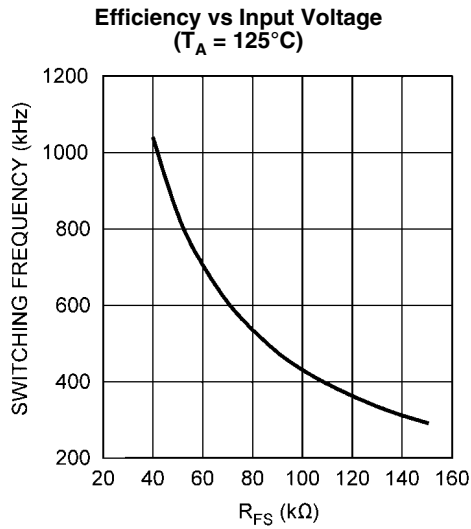

30046715

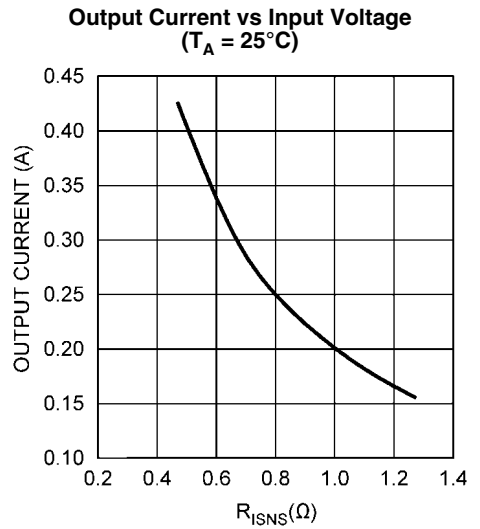

30046716

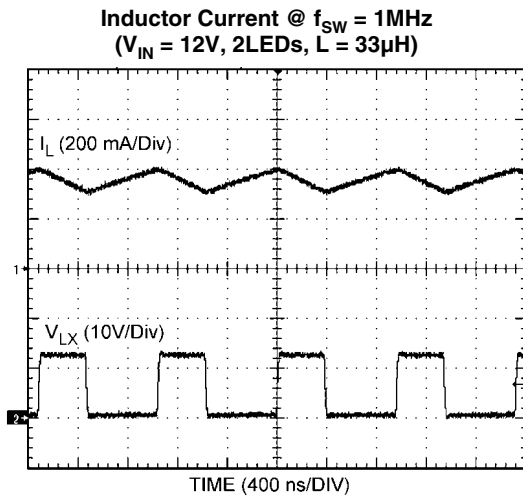

30046718

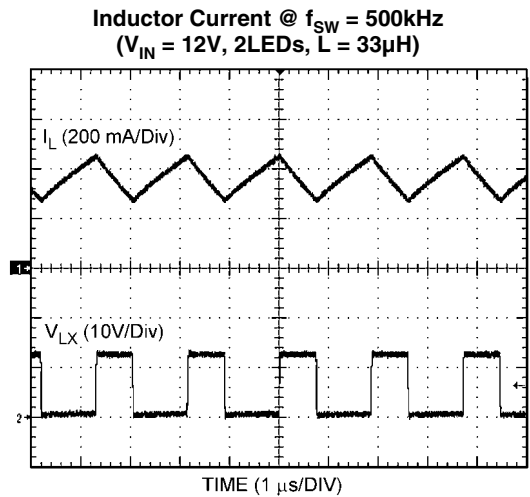

30046719

Inductor Current @ $f_{SW} = 1\text{MHz}$
($V_{IN} = 24\text{V}$, 2LEDs, $L = 33\mu\text{H}$)

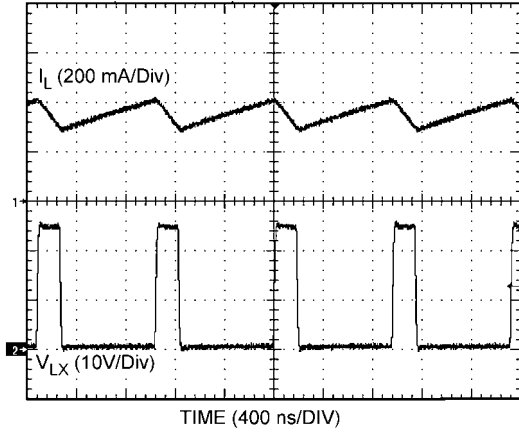

30046720

Inductor Current @ $f_{SW} = 500\text{kHz}$
($V_{IN} = 24\text{V}$, 2LEDs, $L = 33\mu\text{H}$)

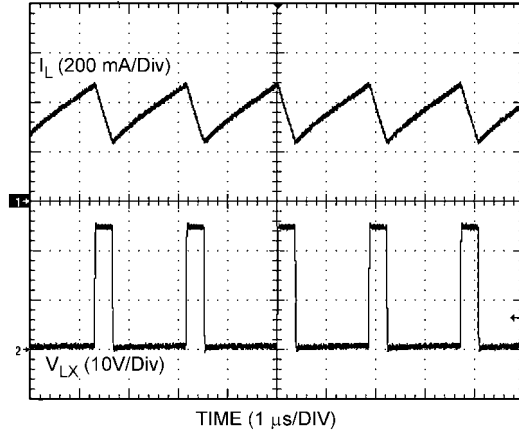

30046721

DIM Pin Enable
($V_{IN} = 24\text{V}$, 2LEDs, $L = 33\mu\text{H}$, $f_{SW} = 500\text{kHz}$)

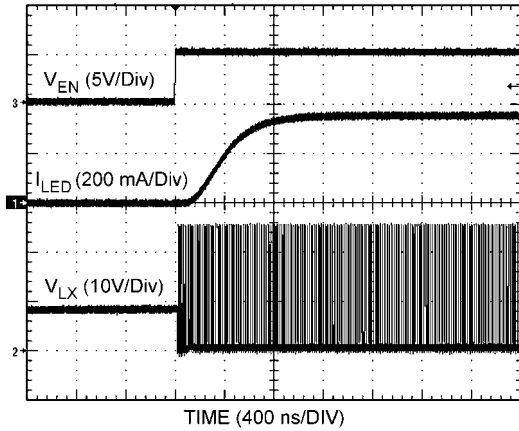

30046722

DIM Pin Disable
($V_{IN} = 24\text{V}$, 2LEDs, $L = 33\mu\text{H}$, $f_{SW} = 500\text{kHz}$)

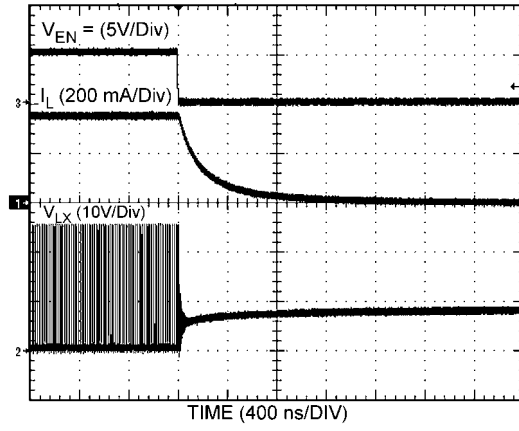

30046723

Notes

For more National Semiconductor product information and proven design tools, visit the following Web sites at:

Products		Design Support	
Amplifiers	www.national.com/amplifiers	WEBENCH® Tools	www.national.com/webench
Audio	www.national.com/audio	App Notes	www.national.com/appnotes
Clock and Timing	www.national.com/timing	Reference Designs	www.national.com/refdesigns
Data Converters	www.national.com/adc	Samples	www.national.com/samples
Interface	www.national.com/interface	Eval Boards	www.national.com/evalboards
LVDS	www.national.com/lvds	Packaging	www.national.com/packaging
Power Management	www.national.com/power	Green Compliance	www.national.com/quality/green
Switching Regulators	www.national.com/switchers	Distributors	www.national.com/contacts
LDOs	www.national.com/ldo	Quality and Reliability	www.national.com/quality
LED Lighting	www.national.com/led	Feedback/Support	www.national.com/feedback
Voltage Reference	www.national.com/vref	Design Made Easy	www.national.com/easy
PowerWise® Solutions	www.national.com/powerwise	Solutions	www.national.com/solutions
Serial Digital Interface (SDI)	www.national.com/sdi	Mil/Aero	www.national.com/milaero
Temperature Sensors	www.national.com/tempsensors	Solar Magic®	www.national.com/solarmagic
Wireless (PLL/VCO)	www.national.com/wireless	Analog University®	www.national.com/AU

THE CONTENTS OF THIS DOCUMENT ARE PROVIDED IN CONNECTION WITH NATIONAL SEMICONDUCTOR CORPORATION ("NATIONAL") PRODUCTS. NATIONAL MAKES NO REPRESENTATIONS OR WARRANTIES WITH RESPECT TO THE ACCURACY OR COMPLETENESS OF THE CONTENTS OF THIS PUBLICATION AND RESERVES THE RIGHT TO MAKE CHANGES TO SPECIFICATIONS AND PRODUCT DESCRIPTIONS AT ANY TIME WITHOUT NOTICE. NO LICENSE, WHETHER EXPRESS, IMPLIED, ARISING BY ESTOPPEL OR OTHERWISE, TO ANY INTELLECTUAL PROPERTY RIGHTS IS GRANTED BY THIS DOCUMENT.

TESTING AND OTHER QUALITY CONTROLS ARE USED TO THE EXTENT NATIONAL DEEMS NECESSARY TO SUPPORT NATIONAL'S PRODUCT WARRANTY. EXCEPT WHERE MANDATED BY GOVERNMENT REQUIREMENTS, TESTING OF ALL PARAMETERS OF EACH PRODUCT IS NOT NECESSARILY PERFORMED. NATIONAL ASSUMES NO LIABILITY FOR APPLICATIONS ASSISTANCE OR BUYER PRODUCT DESIGN. BUYERS ARE RESPONSIBLE FOR THEIR PRODUCTS AND APPLICATIONS USING NATIONAL COMPONENTS. PRIOR TO USING OR DISTRIBUTING ANY PRODUCTS THAT INCLUDE NATIONAL COMPONENTS, BUYERS SHOULD PROVIDE ADEQUATE DESIGN, TESTING AND OPERATING SAFEGUARDS.

EXCEPT AS PROVIDED IN NATIONAL'S TERMS AND CONDITIONS OF SALE FOR SUCH PRODUCTS, NATIONAL ASSUMES NO LIABILITY WHATSOEVER, AND NATIONAL DISCLAIMS ANY EXPRESS OR IMPLIED WARRANTY RELATING TO THE SALE AND/OR USE OF NATIONAL PRODUCTS INCLUDING LIABILITY OR WARRANTIES RELATING TO FITNESS FOR A PARTICULAR PURPOSE, MERCHANTABILITY, OR INFRINGEMENT OF ANY PATENT, COPYRIGHT OR OTHER INTELLECTUAL PROPERTY RIGHT.

LIFE SUPPORT POLICY

NATIONAL'S PRODUCTS ARE NOT AUTHORIZED FOR USE AS CRITICAL COMPONENTS IN LIFE SUPPORT DEVICES OR SYSTEMS WITHOUT THE EXPRESS PRIOR WRITTEN APPROVAL OF THE CHIEF EXECUTIVE OFFICER AND GENERAL COUNSEL OF NATIONAL SEMICONDUCTOR CORPORATION. As used herein:

Life support devices or systems are devices which (a) are intended for surgical implant into the body, or (b) support or sustain life and whose failure to perform when properly used in accordance with instructions for use provided in the labeling can be reasonably expected to result in a significant injury to the user. A critical component is any component in a life support device or system whose failure to perform can be reasonably expected to cause the failure of the life support device or system or to affect its safety or effectiveness.

National Semiconductor and the National Semiconductor logo are registered trademarks of National Semiconductor Corporation. All other brand or product names may be trademarks or registered trademarks of their respective holders.

Copyright© 2009 National Semiconductor Corporation

For the most current product information visit us at www.national.com



National Semiconductor Americas Technical Support Center
Email: support@nsc.com
Tel: 1-800-272-9959

National Semiconductor Europe Technical Support Center
Email: europe.support@nsc.com
German Tel: +49 (0) 180 5010 771
English Tel: +44 (0) 870 850 4288

National Semiconductor Asia Pacific Technical Support Center
Email: ap.support@nsc.com

National Semiconductor Japan Technical Support Center
Email: jpn.feedback@nsc.com