

LM3445 120VAC Small Evaluation Board

National Semiconductor
 Application Note 1978
 Matthew Reynolds
 November 10, 2009



Introduction

The demonstration board included in this shipment converts 90V_{AC} to 135V_{AC} input, and drives six, to thirteen series connected LED's at 350 mA average current. The LM3445 switching frequency ranges from about 70 kHz with six series connected LEDs, to about 110 kHz with thirteen series connected LEDs. The switching frequency can be modified to optimize performance, please refer to the LM3445 datasheet for details. This is a four-layer board using the bottom and top layer for component placement. The demonstration board can be modified to adjust the LED forward current, the number of series connected LEDs and switching frequency. Refer to the LM3445 datasheet for detailed instructions.

A bill of materials below describes the parts used on this demonstration board. A schematic and layout have also been included below along with measured performance character-

istics. The above restrictions for the input voltage are valid only for the demonstration board as shipped with the schematic below. Please refer to the LM3445 data sheet for detailed information regarding the LM3445 device, and the application circuit. The board is currently set up to drive six to thirteen series connected LEDs, but the evaluation board may be modified to accept fewer series LEDs. Refer to the LM3445 datasheet for further explanation.

Evaluation Board Operating Conditions

$$V_{IN} = 90V_{AC} \text{ to } 135V_{AC}$$

Six to thirteen series connected LEDs

$$I_{LED} = 350 \text{ mA}$$

Simplified LM3445 Schematic and Efficiency Plot

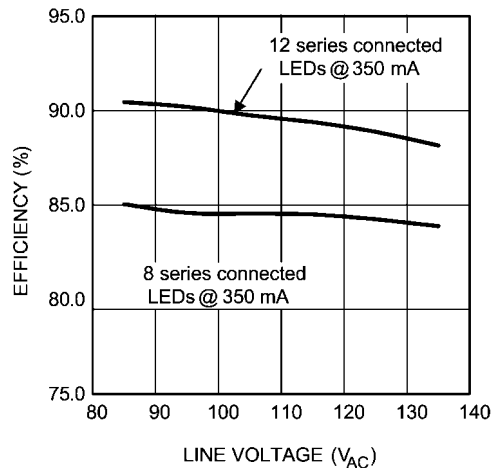
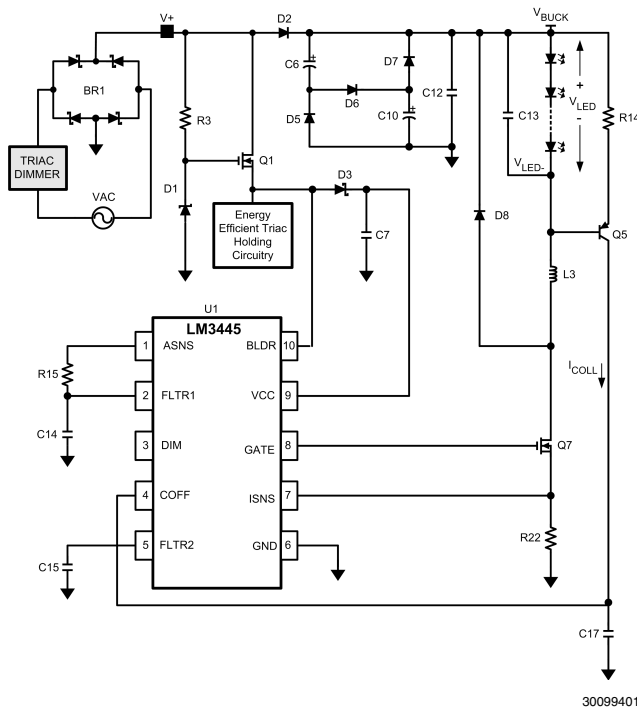

30099402

Warning: The LM3445 evaluation boards have no isolation or any type of protection from shock. Caution must be taken when handling evaluation board. Avoid touching evaluation board, and removing any cables while evaluation board is operating. Isolating the evaluation board rather than the oscilloscope is highly recommended.

Warning: This LM3445 evaluation PCB is a non-isolated design. The ground connection on the evaluation board is NOT referenced to earth ground. If an oscilloscope ground lead is connected to the evaluation board ground test point for analysis, and AC power is applied, the fuse (F1) will fail open. The oscilloscope should be powered via an isolation transformer before an oscilloscope ground lead is connected to the evaluation board.

Pin-Out

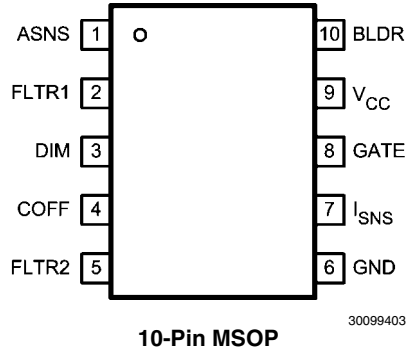

Pin Description 10 Pin MSOP

Pin #	Name	Description
1	ASNS	PWM output of the triac dim decoder circuit. Outputs a 0 to 4V PWM signal with a duty cycle proportional to the triac dimmer on-time.
2	FLTR1	First filter input. The 120Hz PWM signal from ASNS is filtered to a DC signal and compared to a 1 to 3V, 5.85 kHz ramp to generate a higher frequency PWM signal with a duty cycle proportional to the triac dimmer firing angle. Pull above 4.9V (typical) to tri-state DIM.
3	DIM	Input/output dual function dim pin. This pin can be driven with an external PWM signal to dim the LEDs. It may also be used as an output signal and connected to the DIM pin of other LM3445 or LED drivers to dim multiple LED circuits simultaneously.
4	COFF	OFF time setting pin. A user set current and capacitor connected from the output to this pin sets the constant OFF time of the switching controller.
5	FLTR2	Second filter input. A capacitor tied to this pin filters the PWM dimming signal to supply a DC voltage to control the LED current. Could also be used as an analog dimming input.
6	GND	Circuit ground connection.
7	ISNS	LED current sense pin. Connect a resistor from main switching MOSFET source, ISNS to GND to set the maximum LED current.
8	GATE	Power MOSFET driver pin. This output provides the gate drive for the power switching MOSFET of the buck controller.
9	V _{CC}	Input voltage pin. This pin provides the power for the internal control circuitry and gate driver.
10	BLDR	Bleeder pin. Provides the input signal to the angle detect circuitry as well as a current path through a switched 230Ω resistor to ensure proper firing of the triac dimmer.

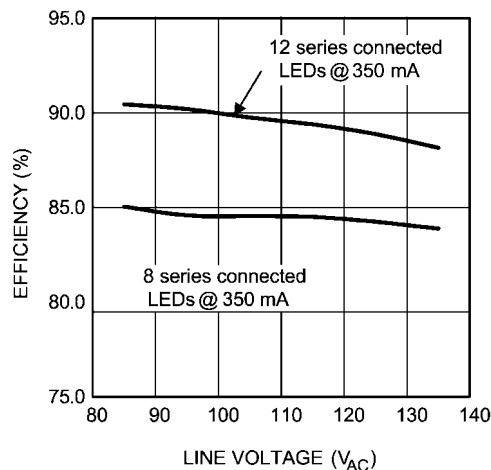

LM3445 Efficiency vs Input Voltage
8 and 12 Series connected LEDs @ 350 mA

30099402

LM3445 Evaluation Board Schematic

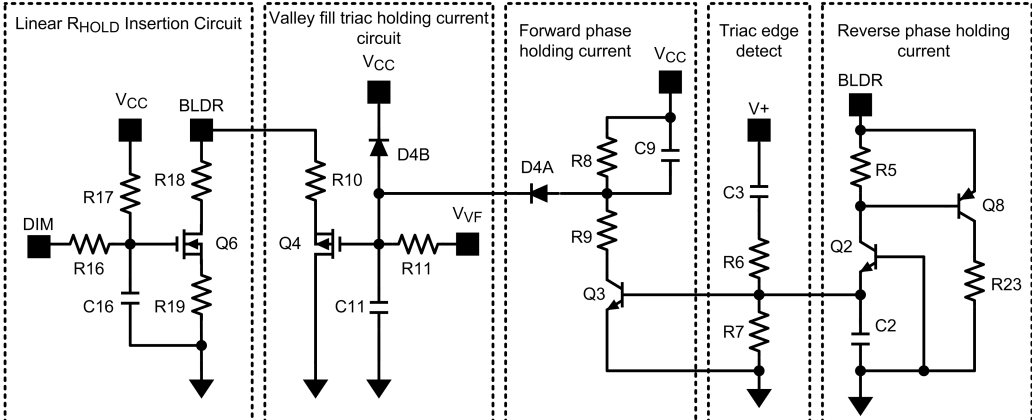
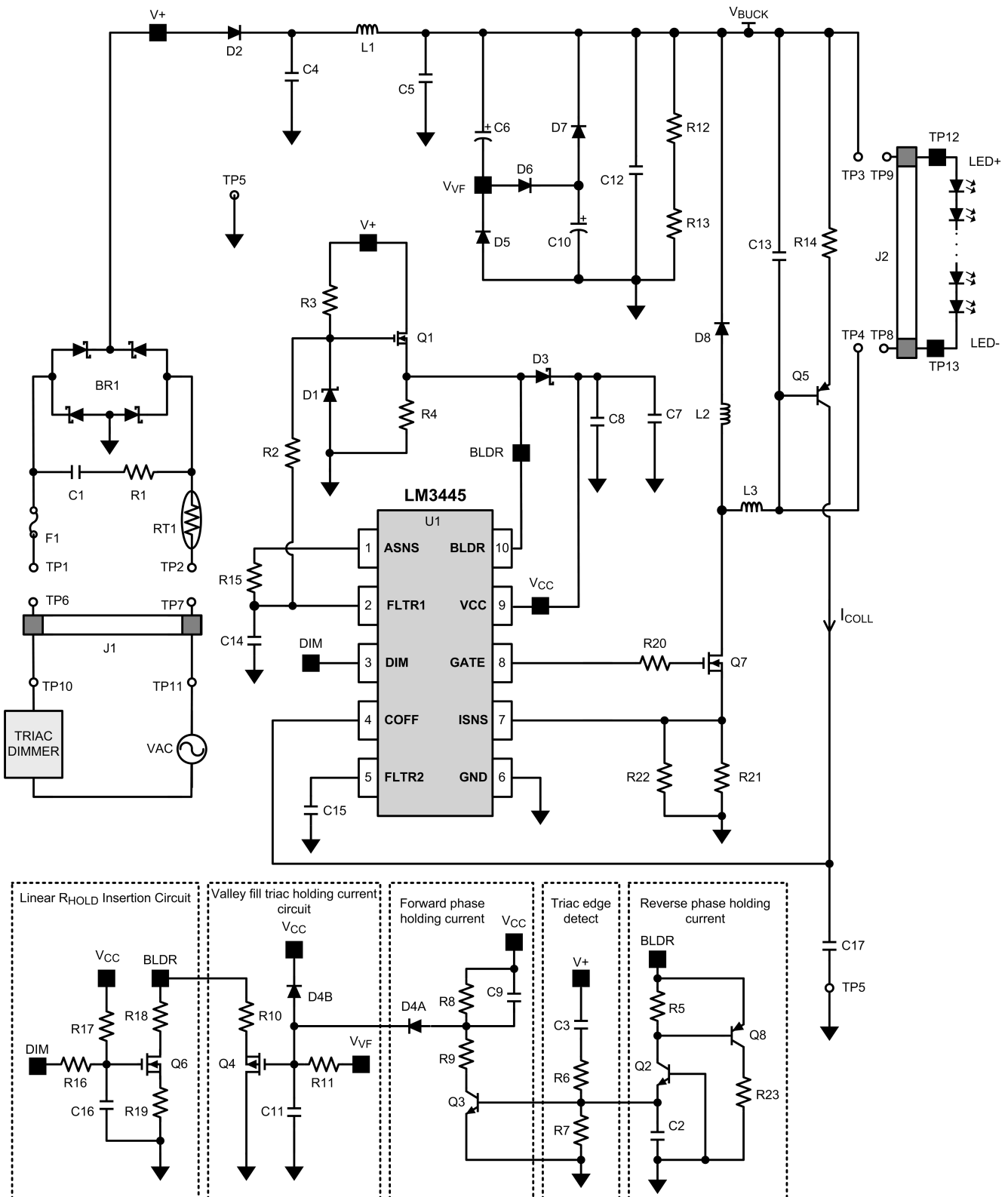

30099408

Bill of Materials LM3445 Evaluation Board

REF DES	Description	MFG	MFG Part Number
U1	IC DRIVER LED W/TRIAC DIM 10MSOP	National Semiconductor	LM3445MM
BR1	Bridge Rectifier Vr = 400V, Io = 0.8A, Vf = 1V	Diodes Inc.	HD04-T
C1	Ceramic .10uF 250V X7R 1210	Taiyo Yuden	QMK325B7104KN-T
C2	Ceramic, 0.01uF, X7R, 25V, 10%	MuRata	GRM188R71E103KA01D
C3	Ceramic, 1000pF 500V X7R 1206	Kemet	C1206C102KCRACU
C4, C5, C12	.01uF	KEMIT	C1808C103KDRACU
C6, C10	CAP 33uF 100V ELECT NHG RADIAL	Panasonic-ECG	ECA-2AHG330
C7, C8	22uF, Ceramic, X5R, 25V, 10%	MuRata	GRM32ER61E226KE15L
C9	4.7uF		C3216X7R1E475K
C11	No Load		
C13	Ceramic, 1.0 uF 100V X7R 1206	Murata	GRM31CR72A105KA01
C14	Ceramic, X7R, 16V, 10%	MuRata	GRM188R71C474KA88D
C15	Ceramic, 0.1uF, X7R, 16V, 10%	MuRata	GRM188R71C104KA01D
C16	Ceramic, 0.22uF, X7R, 16V, 10%	Murata	GRM188R71E224KA88D
C17	Ceramic, 330pF 100V C0G 0603	Murata	GCM1885C2A331JA16D
D1	DIODE ZENER 225MW 15V SOT23	ON Semiconductor	BZX84C15LT1G
D2, D3, D5, D6, D7	DIODE FAST REC 200V 1A	Rohm Semiconductor	RF071M2STR
D4	DIODE SWITCH SS DUAL 70V SOT323	Fairchild	BAV99WT1G
D8	DIODE SUPER FAST 200V 1A SMB	Diodes Inc	MURS120-13-F
F1	FUSE 1A 125V FAST	Cooper/Bussman	6125FA1A
J1, J2	Conn, Term Block 2POS	Phoenix Contact	1715721
L1	INDUCTOR 1000UH .27A SMD SHIELD	Murata Power sol	46105C
L2	10mH, FERRITE CHIP POWER 160 OHM	Steward	HI1206T161R-10
L3	1mH, Shielded Drum Core,	Coilcraft Inc.	MSS1260-105
Q1	MOSFET N-CHAN 250V 4.4A DPAK	Fairchild	FDD6N25
Q2, Q3	TRANS NPN 350MW 40V SMD SOT23	Diodes Inc	MMBT4401-7-F
Q4	MOSFET P-CH 50V 130MA SOT-323	Diodes Inc	BSS84W-7-F
Q5	TRANS HIVOLT PNP AMP SOT-23	Fairchild	MMBTA92
Q6	MOSFET N-CHANNEL 100V SOT323	Diodes Inc	BSS123W-7-F
Q7	MOSFET N-CH 200V POWERPAK 8-SOIC	Vishay/Siliconix	Si7464DP
Q8	TRANS PNP LP 100MA 30V SOT23	ON Semiconductor	BC858CLT1G
R1	330ohm 2512 5% Resistor	Vishay/Dale	CRCW2512330RJNEG
R2	4.75M, 0805, 1%, 0.125W	Vishay-Dale	CRCW08054M75FKEA
R3	1%, 0.25W	Vishay-Dale	CRCW1206332kFKEA
R4	(No Load) 0805		
R5, R16	RES 49.9K OHM, 0.1W, 1% 0603	Vishay-Dale	CRCW060349k9FKEA
R6	RES 100K OHM, 0.25W1%, 1206	Vishay-Dale	CRCW1206100kFKEA
R7	RES 7.50K OHM, 0.1W, 1% 0603	Vishay-Dale	CRCW06037k50FKEA
R8	RES 10.0K OHM, 0.1W, 1% 0603	Vishay-Dale	CRCW060310k0FKEA
R9	RES 100 OHM, 0.25W1%, 1206	Vishay-Dale	CRCW1206100RFKEA
R10	RES 124 OHM, 0.25W1%, 1206	Vishay-Dale	CRCW1206124RFKEA
R11	RES 200K OHM, 0.125W, 1%, 0805	Vishay-Dale	CRCW0805200kFKEA
R12, R13	RES 1.0M OHM, 0.125W, 1%, 0805	Vishay-Dale	CRCW08051M00FKEA
R14	RES 576K OHM, 1/10W 1% 0603	Vishay-Dale	CRCW0603576kFKEA
R15	RES 280K OHM, 1/10W 1% 0603	Vishay-Dale	CRCW0603280kFKEA
R17	(No Load) 0603		
R18	RES 301 OHM, 0.25W1%, 1206	Vishay-Dale	CRCW1206301RFKEA
R19	RES 49.9 OHM, 0.125W, 1%, 0805	Vishay-Dale	CRCW080549R9FKEA

REF DES	Description	MFG	MFG Part Number
R20	RES 4.99 OHM 1/8W 1% 0805	Vishay-Dale	CRCW08054R99FKEA
R21	RES 12.1 OHM, 0.25W1%, 1206	Vishay-Dale	CRCW120612R1FKEA
R22	RES 1.8 OHM 1/3W 5% 1210	Vishay-Dale	CRCW12101R80JNEA
R23	RES 499 OHM, 0.25W1%, 1206	Vishay-Dale	CRCW1206499RFKEA
RT1	CURRENT LIM INRUSH 60OHM 20%	Canterm	MF72-060D5
TP10-TP13	Terminal, Turret, TH, Double	Keystone Electronics	1503-2

PCB Layout

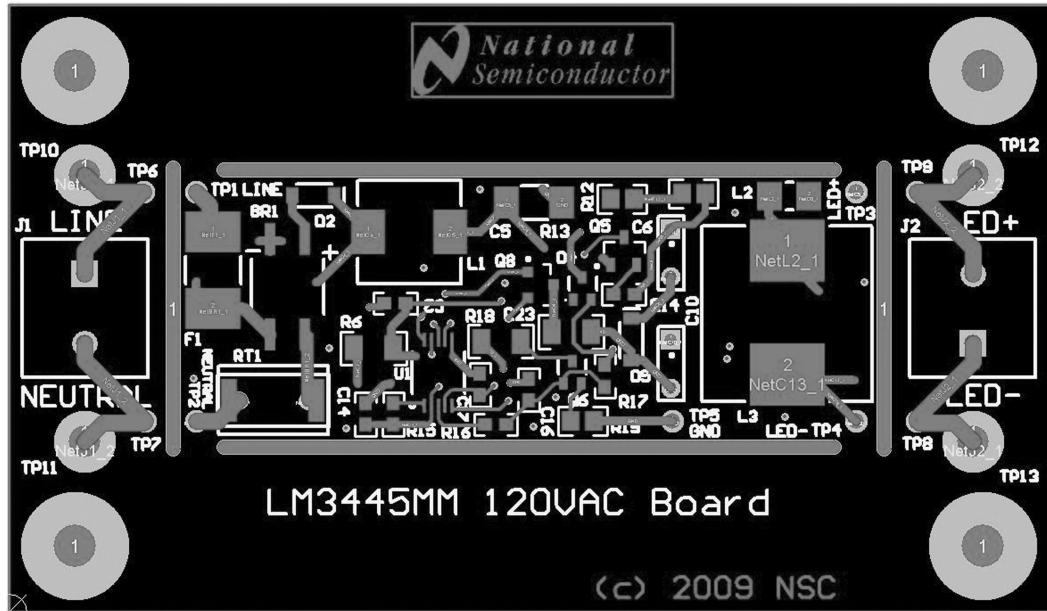

Top Layer

30099410

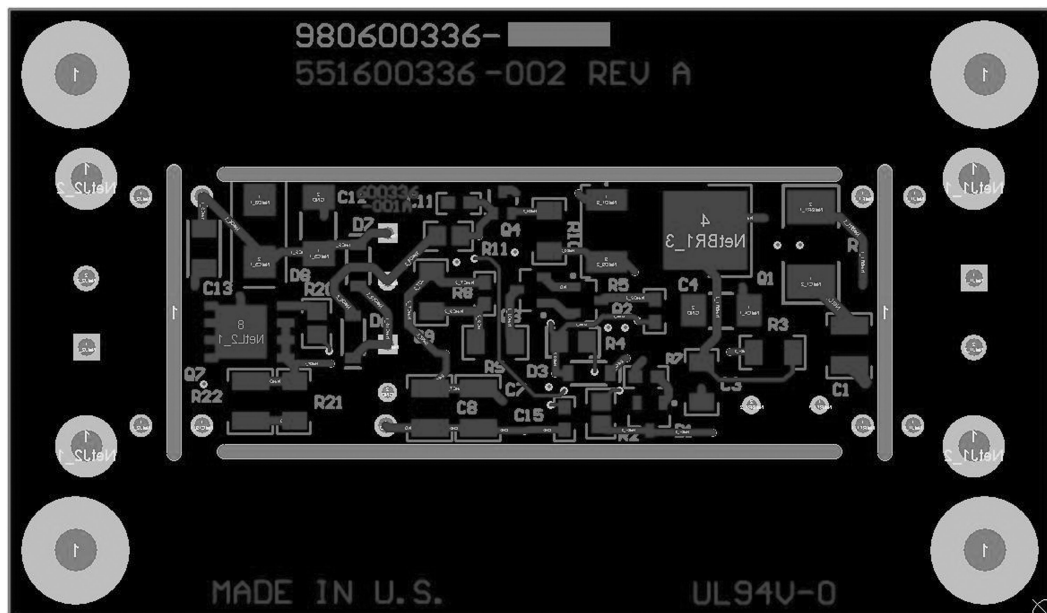

Bottom Layer

30099409

Warning: The LM3445 evaluation boards have no isolation or any type of protection from shock. Caution must be taken when handling evaluation board. Avoid touching evaluation board, and removing any cables while evaluation board is operating. Isolating the evaluation board rather than the oscilloscope is highly recommended.

Notes

AN-1978

Notes

For more National Semiconductor product information and proven design tools, visit the following Web sites at:

Products		Design Support	
Amplifiers	www.national.com/amplifiers	WEBENCH® Tools	www.national.com/webench
Audio	www.national.com/audio	App Notes	www.national.com/appnotes
Clock and Timing	www.national.com/timing	Reference Designs	www.national.com/refdesigns
Data Converters	www.national.com/adc	Samples	www.national.com/samples
Interface	www.national.com/interface	Eval Boards	www.national.com/evalboards
LVDS	www.national.com/lvds	Packaging	www.national.com/packaging
Power Management	www.national.com/power	Green Compliance	www.national.com/quality/green
Switching Regulators	www.national.com/switchers	Distributors	www.national.com/contacts
LDOs	www.national.com/ldo	Quality and Reliability	www.national.com/quality
LED Lighting	www.national.com/led	Feedback/Support	www.national.com/feedback
Voltage Reference	www.national.com/vref	Design Made Easy	www.national.com/easy
PowerWise® Solutions	www.national.com/powerwise	Solutions	www.national.com/solutions
Serial Digital Interface (SDI)	www.national.com/sdi	Mil/Aero	www.national.com/milaero
Temperature Sensors	www.national.com/tempensors	SolarMagic™	www.national.com/solarmagic
Wireless (PLL/VCO)	www.national.com/wireless	PowerWise® Design University	www.national.com/training

THE CONTENTS OF THIS DOCUMENT ARE PROVIDED IN CONNECTION WITH NATIONAL SEMICONDUCTOR CORPORATION ("NATIONAL") PRODUCTS. NATIONAL MAKES NO REPRESENTATIONS OR WARRANTIES WITH RESPECT TO THE ACCURACY OR COMPLETENESS OF THE CONTENTS OF THIS PUBLICATION AND RESERVES THE RIGHT TO MAKE CHANGES TO SPECIFICATIONS AND PRODUCT DESCRIPTIONS AT ANY TIME WITHOUT NOTICE. NO LICENSE, WHETHER EXPRESS, IMPLIED, ARISING BY ESTOPPEL OR OTHERWISE, TO ANY INTELLECTUAL PROPERTY RIGHTS IS GRANTED BY THIS DOCUMENT.

TESTING AND OTHER QUALITY CONTROLS ARE USED TO THE EXTENT NATIONAL DEEMS NECESSARY TO SUPPORT NATIONAL'S PRODUCT WARRANTY. EXCEPT WHERE MANDATED BY GOVERNMENT REQUIREMENTS, TESTING OF ALL PARAMETERS OF EACH PRODUCT IS NOT NECESSARILY PERFORMED. NATIONAL ASSUMES NO LIABILITY FOR APPLICATIONS ASSISTANCE OR BUYER PRODUCT DESIGN. BUYERS ARE RESPONSIBLE FOR THEIR PRODUCTS AND APPLICATIONS USING NATIONAL COMPONENTS. PRIOR TO USING OR DISTRIBUTING ANY PRODUCTS THAT INCLUDE NATIONAL COMPONENTS, BUYERS SHOULD PROVIDE ADEQUATE DESIGN, TESTING AND OPERATING SAFEGUARDS.

EXCEPT AS PROVIDED IN NATIONAL'S TERMS AND CONDITIONS OF SALE FOR SUCH PRODUCTS, NATIONAL ASSUMES NO LIABILITY WHATSOEVER, AND NATIONAL DISCLAIMS ANY EXPRESS OR IMPLIED WARRANTY RELATING TO THE SALE AND/OR USE OF NATIONAL PRODUCTS INCLUDING LIABILITY OR WARRANTIES RELATING TO FITNESS FOR A PARTICULAR PURPOSE, MERCHANTABILITY, OR INFRINGEMENT OF ANY PATENT, COPYRIGHT OR OTHER INTELLECTUAL PROPERTY RIGHT.

LIFE SUPPORT POLICY

NATIONAL'S PRODUCTS ARE NOT AUTHORIZED FOR USE AS CRITICAL COMPONENTS IN LIFE SUPPORT DEVICES OR SYSTEMS WITHOUT THE EXPRESS PRIOR WRITTEN APPROVAL OF THE CHIEF EXECUTIVE OFFICER AND GENERAL COUNSEL OF NATIONAL SEMICONDUCTOR CORPORATION. As used herein:

Life support devices or systems are devices which (a) are intended for surgical implant into the body, or (b) support or sustain life and whose failure to perform when properly used in accordance with instructions for use provided in the labeling can be reasonably expected to result in a significant injury to the user. A critical component is any component in a life support device or system whose failure to perform can be reasonably expected to cause the failure of the life support device or system or to affect its safety or effectiveness.

National Semiconductor and the National Semiconductor logo are registered trademarks of National Semiconductor Corporation. All other brand or product names may be trademarks or registered trademarks of their respective holders.

Copyright© 2009 National Semiconductor Corporation

For the most current product information visit us at www.national.com



National Semiconductor Americas Technical Support Center
Email: support@nsc.com
Tel: 1-800-272-9959

National Semiconductor Europe Technical Support Center
Email: europe.support@nsc.com

National Semiconductor Asia Pacific Technical Support Center
Email: ap.support@nsc.com

National Semiconductor Japan Technical Support Center
Email: jpn.feedback@nsc.com