

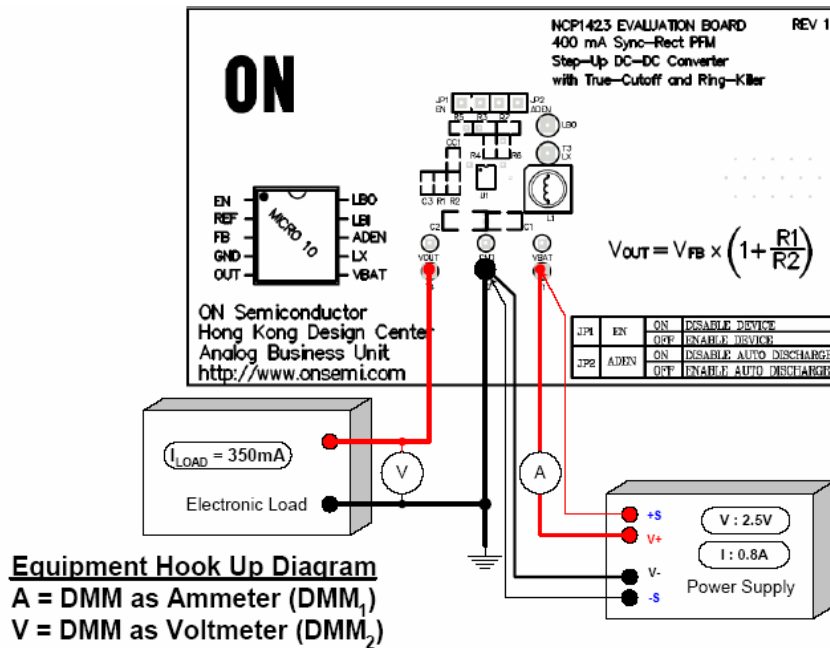

Test Procedure for the NCP1423EVB



Equipment Hook Up Diagram
A = DMM as Ammeter (DMM₁)
V = DMM as Voltmeter (DMM₂)

Figure 1: Equipment Connection Diagram

Table 1: Required Equipment

Oscilloscope (optional)	Ammeter (DMM ₁)	Voltmeter (DMM ₂)
DC Power Supply	One NCP1423 Evaluation Board	Electronic Load

Test Procedure:

3.3V Output Version

1. Setup the Equipments

- Set the power supply voltage to 2.5 V.
- Set the electronic load loading current to 50 mA.
- DMM₁ (A) as ammeter, measures the input current (I_{IN}).
- DMM₂ (V) as voltmeter, measures the output voltage (V_{OUT}).

2. Connect the equipment and the demo board. (Figure 1)

- Connect a power supply with 4-wire sensing across V_{BAT} and GND.
- Connect an electronic load across V_{OUT} and GND.

3. Setup the Demo Board Jumpers. (Refer to table on board)

- Remove the jumper link from:
 - JP1 to Enable the device
 - JP2 to Enable Auto Discharge

4. Measuring Result:

a. For $I_{OUT} = 50$ mA, measure

$V_{OUT} = 3.15$ V to 3.45 V

$I_{IN} = 70$ mA to 80 mA

b. For $I_{OUT} = 350$ mA, measure

$V_{OUT} = 3.15$ V to 3.45 V

$I_{IN} = 490$ mA to 540 mA

5. LBO Test

- Set V_{BAT} low, between 1.1 V and 1.3 V; measure the voltage at LBO pin. LBO voltage status will change from Low to High as V_{BAT} is changed from low to high.

6. ADEN Test

With very small or no load, set the ADEN pin (JP2) to enable. Measure the output voltage waveforms or the time it takes for V_{OUT} to discharge on the voltmeter. Repeat for ADEN disabled. The output voltage discharge time should be faster when ADEN is enabled than when it is disabled.