



MAX15041 Evaluation Kit

General Description

The MAX15041 evaluation kit (EV kit) is a fully assembled and tested circuit board that evaluates the MAX15041 synchronous buck converter IC with integrated high-side and low-side switches. The EV kit output is configured to 3.3V and delivers up to 3A output current. The EV kit circuit operates at the MAX15041 internally set 350kHz switching frequency and features PCB pads to monitor the IC power-good output signal (PGOOD) and to enable the circuit.

The MAX15041 EV kit requires a 4.5V to 28V power supply that provides up to 3A for normal operation.

Features

- ◆ 4.5V to 28V Input-Voltage Range
- ◆ 3.3V at 3A Output
- ◆ Fixed 350kHz Switching Frequency
- ◆ Evaluates Internal 170mΩ R_{DS-ON} High-Side and 105mΩ R_{DS-ON} Low-Side Power Switches
- ◆ High Efficiency Up to 93%
- ◆ Enable Input (EN)
- ◆ Power-Good Output (PGOOD)
- ◆ Overcurrent and Thermal-Shutdown Protection
- ◆ Fully Assembled and Tested

Ordering Information

PART	TYPE
MAX15041EVKIT+	EV Kit

+Denotes lead(Pb)-free and RoHS compliant.

Component List

DESIGNATION	QTY	DESCRIPTION
C1	1	47μF ±20%, 35V electrolytic ceramic capacitor (6.3mm x 5.8mm) Panasonic EEEFK1V470P
C2	1	1μF ±10%, 16V X5R ceramic capacitor (0603) Murata GRM188R61C105K
C3	1	0.1μF ±10%, 50V X7R ceramic capacitor (0603) Murata GRM188R71H104K
C4, C7	2	0.01μF ±10%, 50V X7R ceramic capacitors (0603) Murata GRM188R71H103K
C5	1	22μF ±10%, 6.3V X5R ceramic capacitor (1206) Murata GRM31CR60J226K
C6	0	Not installed, ceramic capacitor (1206)
C8	1	100pF ±5%, 50V C0G ceramic capacitor (0603) Murata GRM1885CIH101J
C9	1	12000pF ±10%, 16V X7R ceramic capacitor (0603) Murata GRM188R71C123K

DESIGNATION	QTY	DESCRIPTION
C10	0	Not installed, ceramic capacitor (0603)
D1	1	150mA, 75V diode (SOD323) Diodes, Inc. 1N4148WS-7-F (Top Mark: T4 or T6)
JU1	1	3-pin header
L1	1	4.7μH, 6.4A inductor Sumida CDRH105RNP-4R7N
R1, R2, R6	3	10kΩ ±1% resistors (0603)
R3	1	1.8kΩ ±1% resistor (0603)
R5	1	45.3kΩ ±1% resistor (0603)
R7	0	Not installed, resistor (0603)
R8	1	47Ω ±5% resistor (0603)
U1	1	Internal switch buck converter (16 TQFN-EP*) Maxim MAX15041ETE+ (Top Mark: AGV)
—	1	Shunt (JU1)
—	1	PCB: MAX15041 EVALUATION KIT+

*EP = Exposed pad.



MAX15041 Evaluation Kit

Component Suppliers

SUPPLIER	PHONE	WEBSITE
Diodes, Inc.	805-446-4800	www.diodes.com
Murata North America Electronics, Inc.	770-436-1300	www.murata-northamerica.com
Panasonic Corp.	800-344-2112	www.panasonic.com
Sumida Corp.	847-545-6700	www.sumida.com

Note: Indicate that you are using the MAX15041 when contacting these component suppliers.

Quick Start

Required Equipment

- 28V adjustable, 3A power supply
- Electronic load capable of sinking up to 3A (e.g., HP 6060B)
- Two digital voltmeters (DVMs)

Procedure

The MAX15041 EV kit is fully assembled and tested. Follow the steps below to verify board operation.

Caution: Do not turn on the power supply until all connections are completed.

- 1) Verify that a shunt is installed across pins 1-2 of jumper JU1. (EV kit enabled)
- 2) Connect the power-supply positive and ground terminals to the VIN and PGND PCB pads, respectively.
- 3) Connect the positive and negative terminal of the electronic load to the VOUT and PGND PCB pads, respectively.
- 4) Connect a DVM across the VOUT and PGND PCB pads.
- 5) Connect a DVM across the PGOOD and SGND PCB pads.
- 6) Turn on the power supply.
- 7) Set the power-supply voltage to 12V.
- 8) Enable the 3A electronic load.
- 9) Verify that the voltmeter connected to VOUT measures 3.3V.
- 10) Verify that the voltmeter connected to PGOOD measures approximately 5V.

Detailed Description of Hardware

The MAX15041 EV kit circuit uses a MAX15041 step-down converter IC to implement a step-down DC-DC converter circuit. The MAX15041 IC is available in a 16-pin TQFN surface-mount package and features a fixed 350kHz switching frequency and internal low R_{DS-ON} MOSFETs to achieve high efficiency and lower overall system cost. The MAX15041 EV kit operates over a wide input-voltage range of 4.5V to 28V.

The MAX15041 EV kit is configured to 3.3V using resistors R5 and R6 and delivers up to 3A of output current. The EV kit circuit soft-start startup time is set to 1.2ms using capacitor C7. The EV kit also provides a PGOOD PCB pad to monitor the IC power-good output signal and an EN PCB pad to enable/disable the EV kit VOUT output.

Input Power Source

The MAX15041 EV kit VOUT output is optimized to provide up to 3A when operating with an input-voltage source of 4.5V to 28V applied at the VIN and PGND pads. Refer to the TOC 19, 20, and 21 curves in the *Typical Operating Characteristic* section in the MAX15041 IC data sheet for current deration for different EV kit VIN inputs and VOUT outputs .

Configuring the Output Voltage (VOUT)

The MAX15041 EV kit step-down converter output voltage is configured to 3.3V by resistors R5 and R6. The EV kit's output voltage (VOUT) can be reconfigured in the 0.606V to 0.9 × VIN range by replacing resistors R5 and R6. Use the following equation to reconfigure the output voltage to the desired value:

$$R5 = R6 \times \left(\frac{V_{OUT}}{0.606} - 1 \right)$$

where V_{OUT} is the desired output voltage, R6 is 10kΩ (typ), and R5 is in kilohms.

MAX15041 Evaluation Kit

Evaluates: MAX15041

Reconfiguring the MAX15041 EV kit for a new output voltage may require replacing inductor L1, capacitors C1 and/or C5, and compensation components C8, C9, and R3. The minimum output voltage is also impacted by minimum controllable on time of the MAX15041 IC. To select a new value for inductor L1, and capacitors C1 and C5, refer to the *Inductor Selection*, *Input Capacitor Selection*, and *Output-Capacitor Selection* sections, respectively, in the MAX15041 IC data sheet.

Enable Control (JU1)

Jumper JU1 configures the MAX15041 EV kit output for turn-on/turn-off control. Install a shunt across pins 1-2 to enable VOUT or across pins 2-3 to disable VOUT. VOUT can also be enabled by applying an external signal greater than 1.95V (typ) at the EN and SGND PCB pads. See Table 1 for proper JU1 configuration.

Table 1. Enable Control (JU1)

SHUNT POSITION	EN PIN	EV KIT FUNCTION
1-2	Connected to VIN through R1	VOUT enabled
2-3	Connected to GND	VOUT disabled
Not installed	Externally controlled	Voltage source applied at EN and SGND PCB pads

Power-Good Output (PGOOD)

The MAX15041 EV kit provides a PCB pad to monitor the status of the power-good output (PGOOD). PGOOD can be used as a system reset signal during power-up. PGOOD is high after VOUT rises above 92.5% of its programmed output voltage. PGOOD is pulled up to VDD (5V, typ) using resistor R2. PGOOD is pulled low when VOUT drops below 90% of its nominal set voltage.

Soft-Start Timing Input (SS)

The MAX15041 EV kit circuit soft-start time is set to 1.2ms using capacitor C7. To reconfigure the EV kit for other soft-start times, refer to the *Setting the Soft-Start Time* section in the MAX15041 IC data sheet.

Compensation Network

The MAX15041 IC provides the flexibility of externally compensating its internal error amplifier to achieve stability for various applications. The MAX15041 EV kit circuit is compensated by appropriately choosing values for resistors R3 and capacitors C8 and C9. To reconfigure the compensation network for specific requirements, refer to the *Compensation Design Guidelines* section in the MAX15041 IC data sheet.

MAX15041 Evaluation Kit

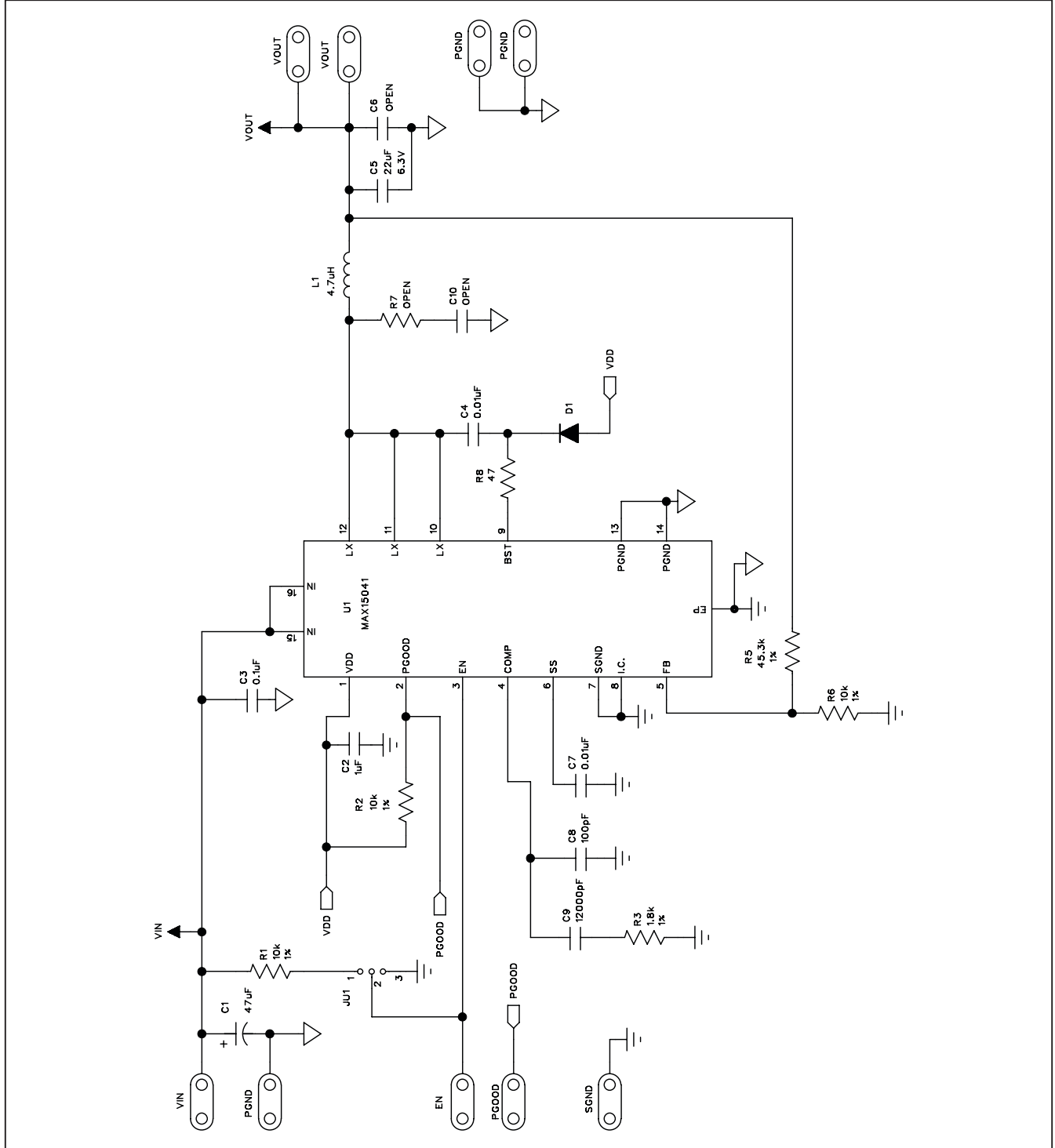

Figure 1. MAX15041 EV Kit Schematic

MAX15041 Evaluation Kit

Evaluates: MAX15041

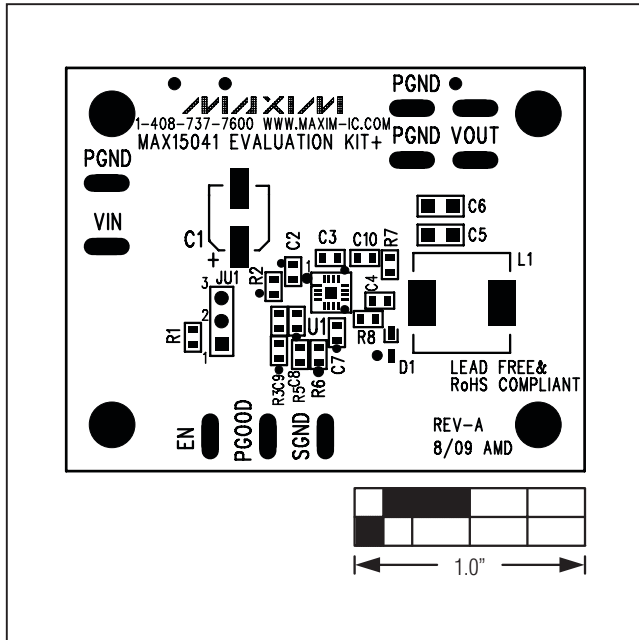

Figure 2. MAX15041 EV Kit Component Placement Guide—Component Side

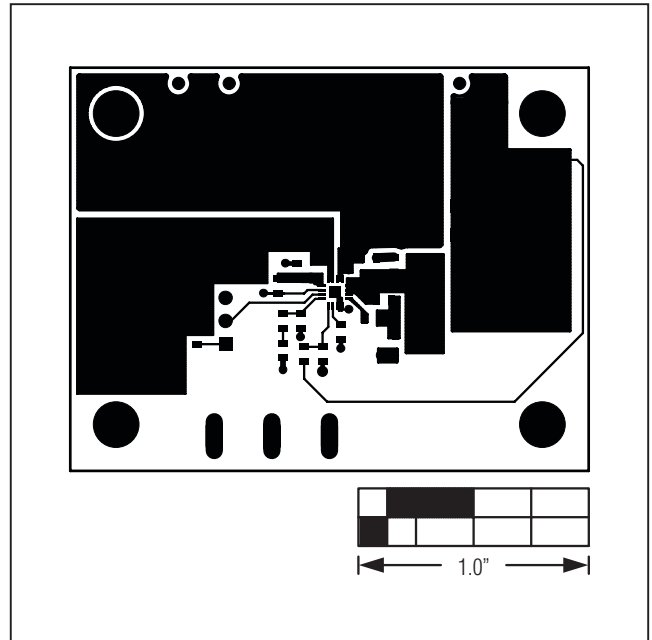

Figure 3. MAX15041 EV Kit PCB Layout—Component Side

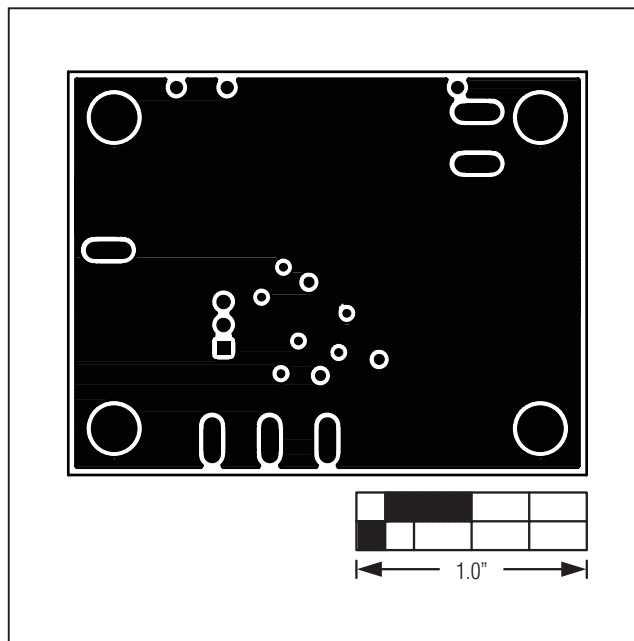

Figure 4. MAX15041 EV Kit PCB Layout—PGND Layer 2

MAX15041 Evaluation Kit

Evaluates: MAX15041

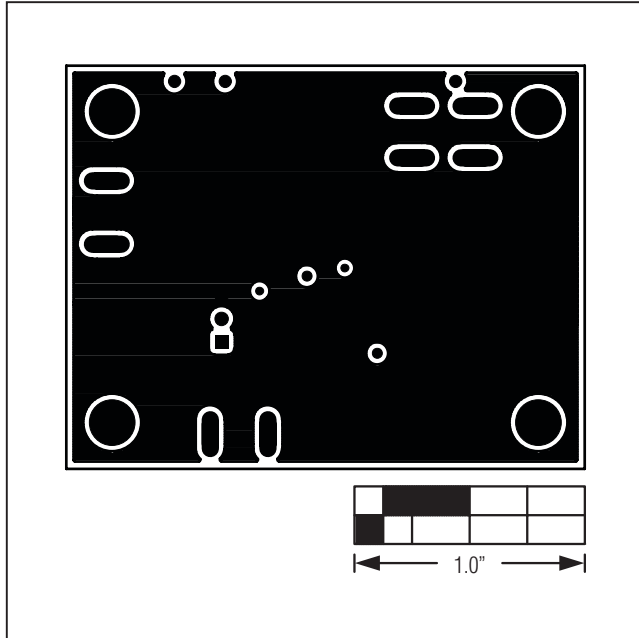

Figure 5. MAX15041 EV Kit PCB Layout—SGND Layer 3

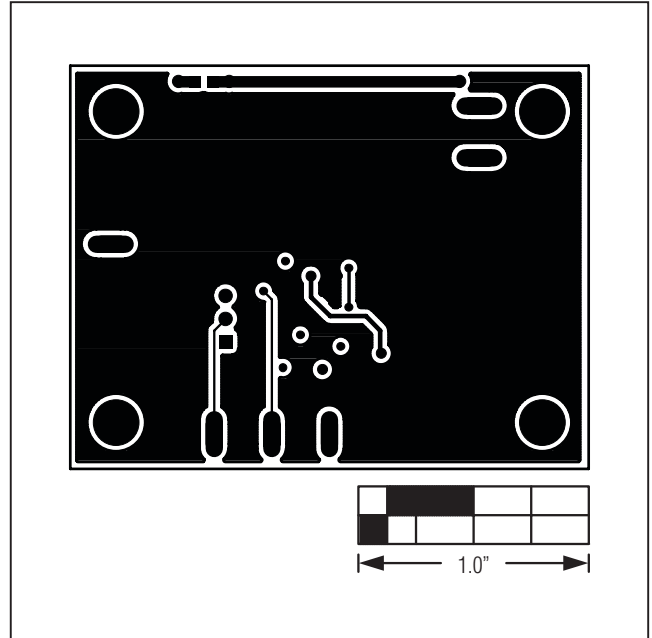

Figure 6. MAX15041 EV Kit PCB Layout—Solder Side

Maxim cannot assume responsibility for use of any circuitry other than circuitry entirely embodied in a Maxim product. No circuit patent licenses are implied. Maxim reserves the right to change the circuitry and specifications without notice at any time.

6 _____ **Maxim Integrated Products, 120 San Gabriel Drive, Sunnyvale, CA 94086 408-737-7600**

© 2009 Maxim Integrated Products

Maxim is a registered trademark of Maxim Integrated Products, Inc.