

LM2750-ADJ Evaluation Board

National Semiconductor
Application Note 1302
March 2004

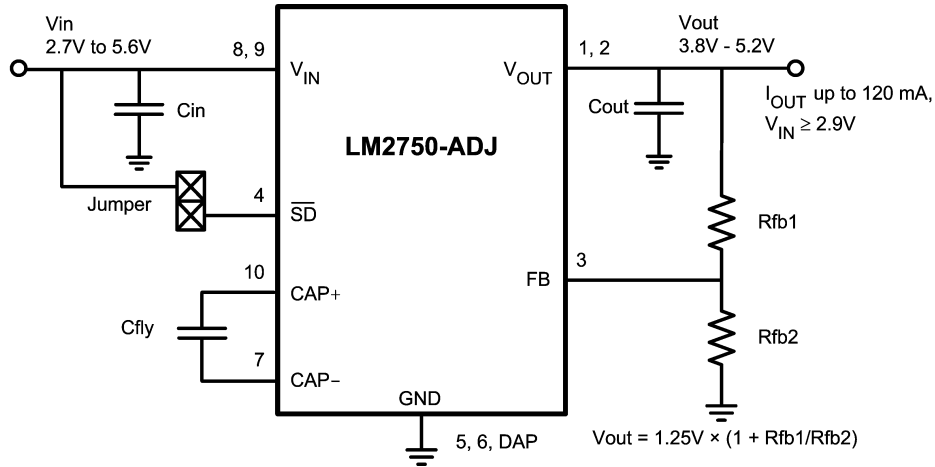

Evaluation Board Schematic



20085201

Components

I.C.

Part #	Package Mark I.D.	Package	Dimensions
LM2750-ADJ	S003B	LLP10 (LDA10A)	3.0mm x 3.0mm x 0.8mm

CAPACITORS

Capacitor Symbol	Value	Case Size U.S. (Metric)	Height	Temperature Characteristic	Mfr.	Part #
Cin	2.2 μ F, 16V*	0805 (2012)	1.25mm	X5R	TDK	C2012X7R1C225K
Cfly	1.0 μ F, 10V*	0603 (1608)	0.8mm	X5R	TDK	C1608X5R1A105K
Cout	2.2 μ F, 16V*	0805 (2012)	1.25mm	X5R	TDK	C2012X7R1C225K

* In order to meet LM2750 minimum capacitance requirements, 10V is the minimum recommended voltage rating for all capacitors. This elevated rating recommendation accounts for capacitance degradation due to DC bias, a common property of ceramic capacitors. For more information on capacitors, refer to the LM2750 datasheet.

RESISTORS

Evaluation Board nominally set to $V_{out} = 4.5V$ with the following resistors:

Resistor Symbol	Value	Case Size U.S. (Metric)	Manufacturer	Part #
Rfb1	11.5k Ω , 1%	0603 (1608)	Vishay-Dale	CRCW06031152F
Rfb2	4.42k Ω , 1%	0603 (1608)	Vishay-Dale	CRCW06034421F

Board Layers

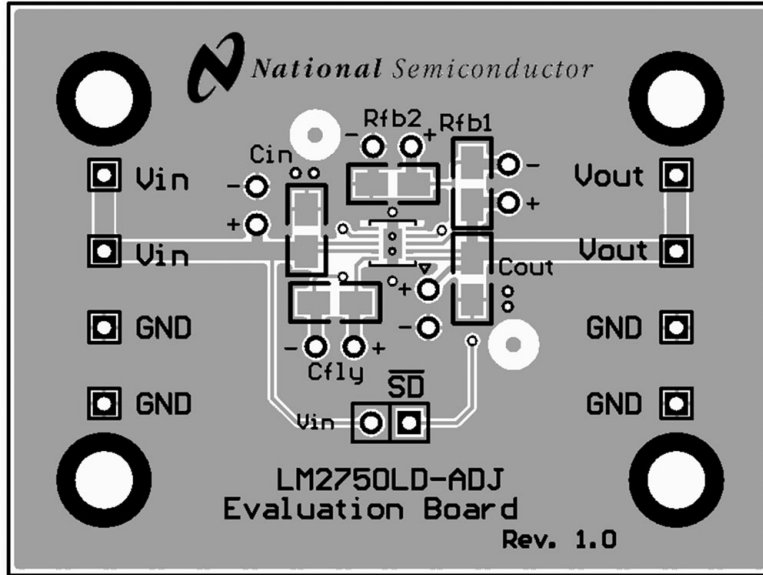

Top Layer, Top View

20085202

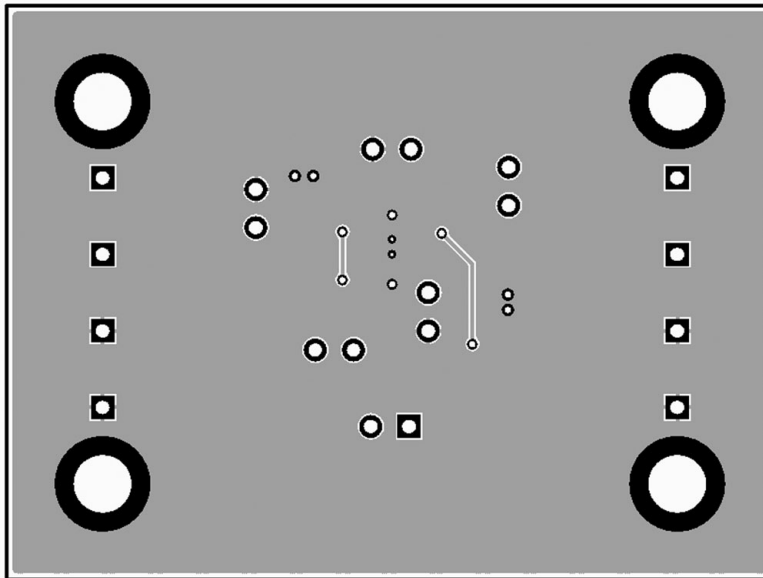

Bottom Layer, Top View (unmirrored)

20085203

Ordering Information

Order #	Description
LM2750EVAL-ADJ	LM2750LD-ADJ Evaluation Board

Part Description

The LM2750-ADJ is a switched-capacitor doubler that produces a low-noise, well regulated output voltage. With a pair of external resistors, the output voltage can easily be set to a level between 3.8V and 5.2V. The LM2750 is provided in National's 10-pin LLP, a package with excellent thermal properties that keeps the part from overheating under almost all rated operating conditions.

A perfect fit for space-constrained, battery-powered applications, the LM2750 requires only 3 external components: one input capacitor, one output capacitor, and one flying capacitor. Small, inexpensive ceramic capacitors are recommended for use. These capacitors, in conjunction with the 1.7MHz fixed switching frequency of the LM2750, yield low output voltage ripple, beneficial for systems requiring a low-noise supply.

Pre-regulation minimizes input current ripple, reducing input noise to negligible levels. A tightly controlled soft-start feature limits inrush currents during part activation. Shutdown completely disconnects the load from the input. Output current limiting and thermal shutdown circuitry protect both the LM2750 and connected devices in the event of output shorts or excessive current loads.

References

LM2750 Product Folder and Datasheet:

<http://www.national.com/pf/LM/LM2750.html>

Application Note 1187 - Leadless Leadframe Package:

<http://www.national.com/an/AN/AN-1187.html>

Board Usage

INPUT

Connect the input and ground pins of the evaluation board to a power supply or battery with short, low-impedance, low-inductance wires or cables. The nominal input voltage range of the LM2750-ADJ is 2.7V to 5.6V, but at lower output voltages ($V_{out} < 4.9V$) the input voltage should never be more than 0.7V below the output voltage.

OUTPUT VOLTAGE AND CURRENT

The output voltage of the LM2750-ADJ can be programmed with a simple resistor divider (see resistors Rfb1 and Rfb2 on the Evaluation Board Schematic). The values of the feedback resistors set the output voltage, as determined by the following equation:

$$V_{out} = 1.23V \times (1 + R_{fb1} / R_{fb2})$$

In the equation above, the "1.23V" term is the nominal voltage of the feedback pin when the feedback loop is correctly established and the part is operating normally. The sum of the resistance of the two feedback resistors should be between 15k Ω and 20k Ω :

$$15k\Omega < (R_{fb1} + R_{fb2}) < 20k\Omega$$

If larger feedback resistors are desired, a 10pF capacitor should be placed in parallel with resistor R1.

The output voltage of the LM2750 is guaranteed to accurate to $\pm 4\%$ when it is set to 5.0V and the part is operated within nominal operating ratings. Regulation is guaranteed for load currents as high as 120mA. The LM2750 is capable of driving load currents up to and above 120mA. The LM2750 datasheet provides information on high load current usage, and datasheet curves illustrate the typical performance of the part with output currents as high as 175mA.

SHUTDOWN

A jumper is present on the evaluation board to bring the LM2750 in and out of shutdown. When the jumper is in place, the \overline{SD} pin is connected to V_{IN} , and the part is operational.

Removing the jumper floats the \overline{SD} pin. A 200k Ω resistor connected internally between the \overline{SD} pin and GND pulls the voltage on the \overline{SD} pin low. This places the LM2750 in shutdown.

Notes

LIFE SUPPORT POLICY

NATIONAL'S PRODUCTS ARE NOT AUTHORIZED FOR USE AS CRITICAL COMPONENTS IN LIFE SUPPORT DEVICES OR SYSTEMS WITHOUT THE EXPRESS WRITTEN APPROVAL OF THE PRESIDENT AND GENERAL COUNSEL OF NATIONAL SEMICONDUCTOR CORPORATION. As used herein:

1. Life support devices or systems are devices or systems which, (a) are intended for surgical implant into the body, or (b) support or sustain life, and whose failure to perform when properly used in accordance with instructions for use provided in the labeling, can be reasonably expected to result in a significant injury to the user.
2. A critical component is any component of a life support device or system whose failure to perform can be reasonably expected to cause the failure of the life support device or system, or to affect its safety or effectiveness.

BANNED SUBSTANCE COMPLIANCE

National Semiconductor certifies that the products and packing materials meet the provisions of the Customer Products Stewardship Specification (CSP-9-111C2) and the Banned Substances and Materials of Interest Specification (CSP-9-111S2) and contain no "Banned Substances" as defined in CSP-9-111S2.



National Semiconductor
Americas Customer
Support Center
Email: new.feedback@nsc.com
Tel: 1-800-272-9959

www.national.com

National Semiconductor
Europe Customer Support Center
Fax: +49 (0) 180-530 85 86
Email: europa.support@nsc.com
Deutsch Tel: +49 (0) 69 9508 6208
English Tel: +44 (0) 870 24 0 2171
Français Tel: +33 (0) 1 41 91 8790

National Semiconductor
Asia Pacific Customer
Support Center
Email: ap.support@nsc.com

National Semiconductor
Japan Customer Support Center
Fax: 81-3-5639-7507
Email: jpn.feedback@nsc.com
Tel: 81-3-5639-7560

National does not assume any responsibility for use of any circuitry described, no circuit patent licenses are implied and National reserves the right at any time without notice to change said circuitry and specifications.