

# LM2731/LM2733 Evaluation Board

National Semiconductor  
Application Note 1280  
April 2003



The LM2731 and LM2733 are high frequency switching boost regulators which offer small size and high power conversion efficiency. The "X" version of the part operates at 1.6MHz switching frequency and the "Y" version at 600kHz. The primary difference between the LM2731 and LM2733 is that the LM2731 has a higher current internal switch FET (with lower breakdown voltage), while the LM2733 has a higher voltage FET which handles less current. The LM2733 targets applications with higher output voltages, while the

LM2731 is intended for applications requiring higher load currents at lower output voltages. This application note will describe the evaluation board supplied to demonstrate the operation of these parts and give information on its usage.

## Basic Application Circuit

The basic application circuit shown below provides the component designators used on the evaluation board.

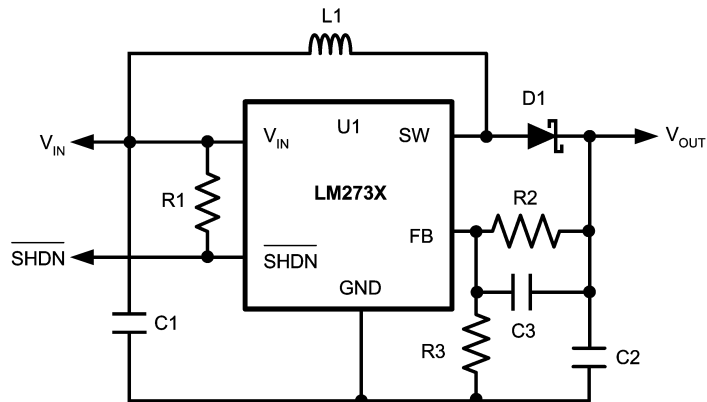

20069101

Eval Board Basic Application Circuit

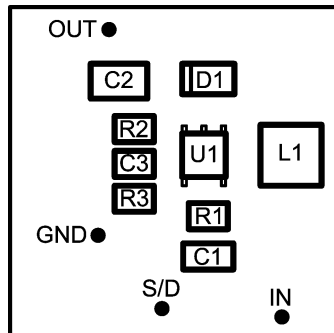

20069102

Eval Board Component Layout

## Component Values

The initial build of evaluation boards were built up in 12V and 24V output versions using different components at selected locations (see **Note 1** below). The components which are common to all boards are:

1. PCB
2. R1, resistor 51k, 5%
3. R3, resistor 13.3k, 1%
4. C1, capacitor, 2.2  $\mu$ F, ceramic, Taiyo-Yuden #EMK316BJ225ML
5. D1, diode, MBR0530
6. L1, inductor: 10  $\mu$ H (Sumida #CR43-100)

The components which are application specific are:

1. C2, output capacitor: a 4.7  $\mu$ F cap is installed on the board for LM2733 (X and Y) and the LM2731X devices. A 10  $\mu$ F output capacitor is used for the LM2731Y devices.
2. R2, resistor which sets output voltage. See section on adjusting the output voltage for details.
3. C3, feed forward capacitor. Dependent on R2, see section on feedforward compensation.

**Note 1:** (addendum 02/06/03) An additional build of eval boards for 3.3V to 5V applications using the LM2731 were made on this date. See Demo Board section for details.

## Adjusting the Output Voltage

The output voltage is set using R2 and R3 as given by the formula:

$$V_{OUT} = 1.23 (R2/R3) + 1.23$$

Solved for R2:

$$R2 = (V_{OUT} - 1.23) / 1.23 \times R3$$

The evaluation board as shipped has a 13.3k resistor installed at R3. The appropriate value for R2 for any output may be calculated from the above formula.

## Feedforward Compensation

The feedforward capacitor C3 should be selected to set the compensation zero at approximately 8 kHz. The value of C3 is calculated using:

$$C3 = 1 / (2 \times \pi \times 8k \times R2)$$

The value of C3 is calculated after R2 is selected for the output voltage needed for the specific application.

## Guidelines for Component Selection

Since it is assumed that some of the eval boards will be modified to be used in different voltage and current configurations, some guidelines are given to help select components which are likely to be changed.

**INDUCTOR L1:** The amount of inductance required depends on switching frequency, duty cycle and amount of allowable ripple current. 10  $\mu$ H is a good choice for most applications. At low boost ratios such as 3.3V to 5V, the LM2731 loop stability requires that the inductance not exceed 6.8  $\mu$ H. Smaller inductors may be used in applications with less output current. Higher ripple current resulting from a smaller inductor means the maximum average current (and power) will be less. Duty cycle also affects ripple current, since the time the switch is ON determines the length of time that the current has to ramp up. Any design must be

verified for maximum load current over the full temperature range of the application to make sure the inductance is sufficient.

Smaller inductors can be used (and make more sense economically) if the load current is fairly light. The part may operate in discontinuous mode (where inductor current drops to zero during each switching cycle) using less inductance, but this is harmless and actually increases stability (phase margin) compared to continuous operation.

**DIODE D1:** Because of the fast switching speeds, a schottky diode must be used for D1. The voltage rating (minimum) should be at least 5V higher than the output voltage for safe design margin. The average current rating of the diode should be at least 50% more than the maximum output load current of the application.

**OUTPUT CAPACITOR C2:** The output capacitor(s) used on the LM273X must be good quality ceramics of the X7R or X5R type. Z5U or Z5F types will not give sufficient capacitance because of the applied voltage reducing effective capacitance.

The output capacitor is also critical for stability. As a basic guideline, it is recommended for the LM2733: 4.7  $\mu$ F minimum, at output voltages of 10V or above. At lower output voltages, use 10 - 22  $\mu$ F. In general, the higher the load current, the more output capacitance is required for stability. For the LM2731: use at least 10  $\mu$ F in 5V to 12V applications, and use 22  $\mu$ F at lower boost ratios (such as 3.3 to 5V).

Stability of the specific application should be verified over the full operating temperature range by load step testing, where the load current is increased from no load to full load abruptly. This can be done simply by tapping the lead from the load box onto the output terminal. The amount of ringing seen on the output voltage waveform will define the stability of the design:

## Output Voltage Waveforms For Stability Testing

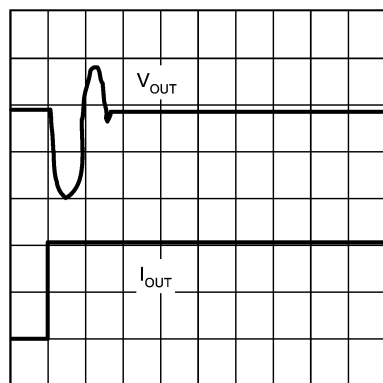

Good Stability

20069103

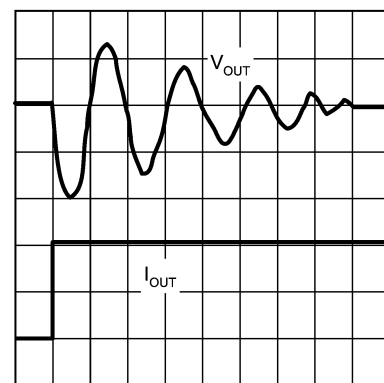

Marginal Stability

20069104

### 3.3V to 5V Demo Boards

3.3V to 5V boards were fabricated using the LM2731X and LM2731Y. These boards had the following changes from the standard BOM listed previously in this document.

1. C2, output capacitor: a 22  $\mu$ F cap is installed on the board. The increased capacitance is necessary for loop stability.
2. R2, is 40.2k to set the output to 5V.
3. C3, is 470 pF (feedforward compensation).
4. L1, is 6.8  $\mu$ H. This is the maximum inductance which the LM2731 will provide stable operation at full load current in the 3.3 to 5V boost configuration.

#### LIFE SUPPORT POLICY

NATIONAL'S PRODUCTS ARE NOT AUTHORIZED FOR USE AS CRITICAL COMPONENTS IN LIFE SUPPORT DEVICES OR SYSTEMS WITHOUT THE EXPRESS WRITTEN APPROVAL OF THE PRESIDENT AND GENERAL COUNSEL OF NATIONAL SEMICONDUCTOR CORPORATION. As used herein:

1. Life support devices or systems are devices or systems which, (a) are intended for surgical implant into the body, or (b) support or sustain life, and whose failure to perform when properly used in accordance with instructions for use provided in the labeling, can be reasonably expected to result in a significant injury to the user.
2. A critical component is any component of a life support device or system whose failure to perform can be reasonably expected to cause the failure of the life support device or system, or to affect its safety or effectiveness.



**National Semiconductor**  
Americas Customer  
Support Center  
Email: new.feedback@nsc.com  
Tel: 1-800-272-9959

www.national.com

**National Semiconductor**  
Europe Customer Support Center  
Fax: +49 (0) 180-530 85 86  
Email: europe.support@nsc.com  
Deutsch Tel: +49 (0) 69 9508 6208  
English Tel: +44 (0) 870 24 0 2171  
Français Tel: +33 (0) 1 41 91 8790

**National Semiconductor**  
Asia Pacific Customer  
Support Center  
Fax: +65-6250 4466  
Email: ap.support@nsc.com  
Tel: +65-6254 4466

**National Semiconductor**  
Japan Customer Support Center  
Fax: 81-3-5639-7507  
Email: jpn.feedback@nsc.com  
Tel: 81-3-5639-7560