

LM267X 3A, 5A Evaluation Boards

National Semiconductor
Application Note 1135
March 4, 2011



Introduction

The LM267X evaluation board was developed for the evaluation of LM267X SIMPLE SWITCHER® series of 3 Amp and 5 Amp high efficiency step-down (Buck) switching voltage regulators. This application note describes the printed circuit board, and provides example circuits and directions on setup and operation of the **LM2673S-5_EVAL** and **LM2679S-5_EVAL** evaluation boards.

General Description

Many of our boards are intended to provide the user with device characterization and layout optimization data. The LM267x evaluation board was intended to allow the user to experiment with a variety of circuit topologies and components, and therefore not optimized for size. Please refer to the discussions of layout optimization in the PCB Layout Optimization section.

This board was designed such that both through-hole and surface-mount components can be used for construction. The

regulator IC can be placed on the board as a surface-mount component only. The ground plane serves as a heatsink.

Table 1 shows an overview of the family of devices with special features of each indicated. Consult the device data sheet, or use the special power supply design software called **Switchers Made Simple version 6.X** (available for free download from National Semiconductor's Internet page, power.national.com) to determine all necessary component values for the particular device being used to accomplish a specific design and board layout considerations.

The printed circuit board, PCB, is labeled to indicate the location of all of the needed components for all possible design options. *Table 2* shows a complete list of the component labels and their functions.

Figure 1 identifies all components, but not all are necessary in every design.

Figure 2, *Figure 3* and *Figure 4* show the top, bottom and silk screen of the printed circuit board respectively.

TABLE 1. LM267X Family of High-Current Regulators supported by the Evaluation Board

Device	Maximum Load Current (A)	Special Features
LM2670	3	ON/OFF, External Frequency Sync Capability
LM2673	3	Adjustable Current Limit, Softstart
LM2676	3	ON/OFF
LM2677	5	ON/OFF, External Frequency Sync. Capability
LM2678	5	ON/OFF
LM2679	5	Adjustable Current Limit, Softstart

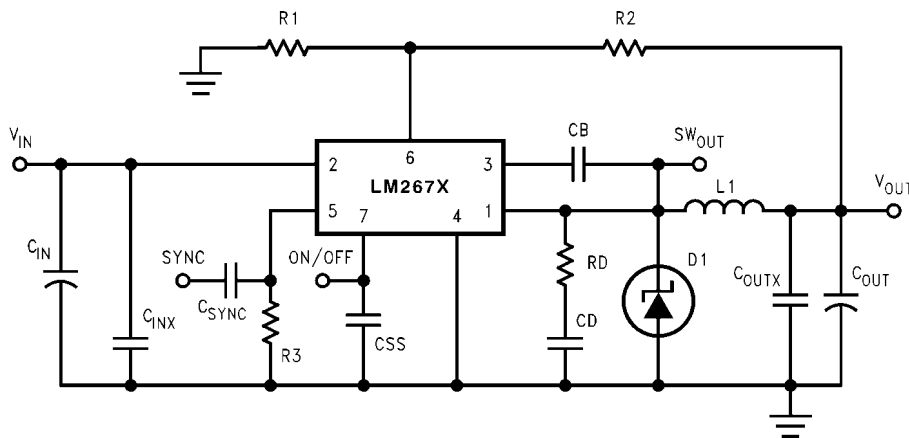

10114501

FIGURE 1. Example Schematic Showing Connection for all Components.

TABLE 2. List of Component Labels and Functionality

Label	Function
U1	LM267X Switching Regulator IC
CIN	Input Capacitor(s); All devices.
CINX	0.47 μ F, optional high frequency input bypass capacitor, recommended in all designs: All devices.
CB	Boost capacitor; All devices.
D1	Catch diode; All devices.
R1	Feedback resistor for adjustable output converters. This designator is left open (not connected) for fixed output converters.
R2	Feedback resistor (typ. 1 k Ω) for adjustable output converters. This designator is left shorted (replaced by a jumper wire) for fixed output voltage converters.
R3*	Current limit resistor for LM2673, LM2679; Sync input resistor (1 k Ω) for LM2670 and LM2677; Not inserted for LM2676 and LM2678.
L1	Inductor; All devices.
CSYNC	Sync input capacitor (100 pF); LM2670 and LM2677 only. Not inserted with other devices.
CSS	Soft start capacitor; LM2673 and LM2679 only. Not inserted with other devices.
COUTX	0.47 μ F, optional high frequency output bypass capacitor; All devices.
COUT	Output capacitor(s); All devices.

*All devices have internally preset current limits, but those with adjustable current limit capability can be used to set the current limit to any value up to the maximum preset value.

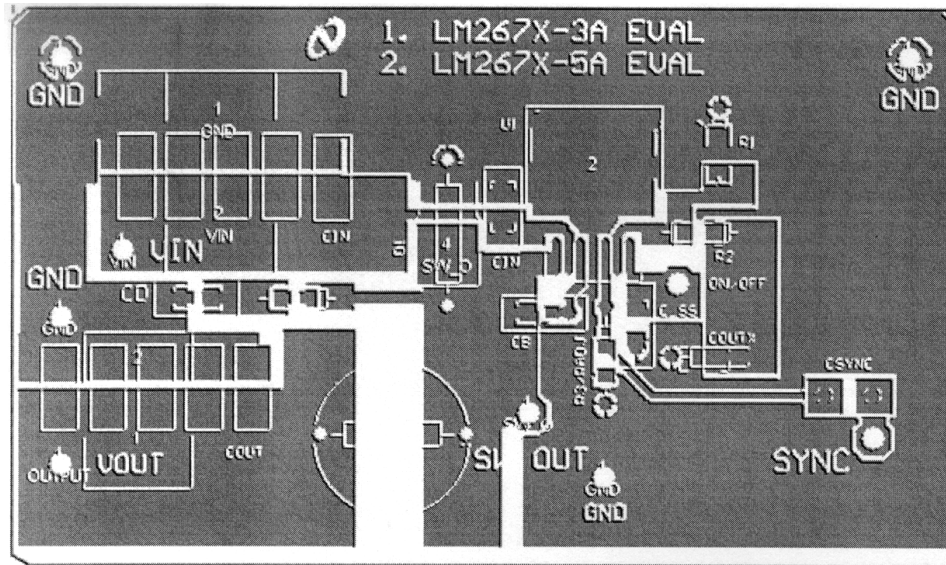

10114502

FIGURE 2. Top Layer Foil Pattern of Printed Circuit Board

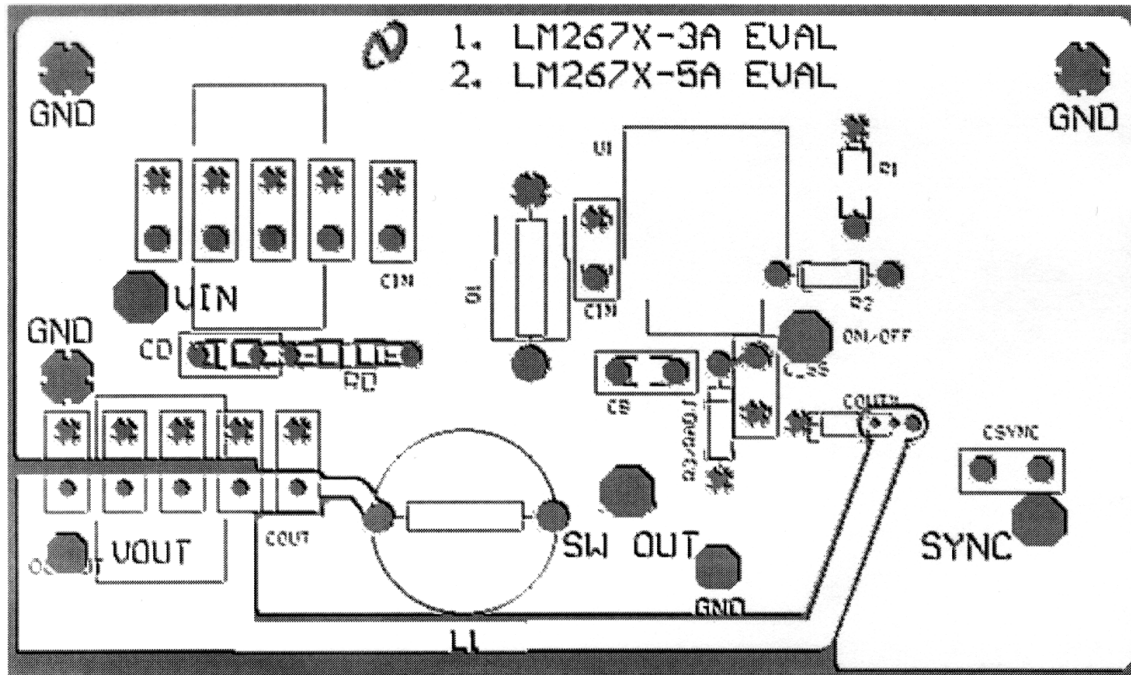

10114503

FIGURE 3. Bottom Layer Foil Pattern of Printed Circuit Board

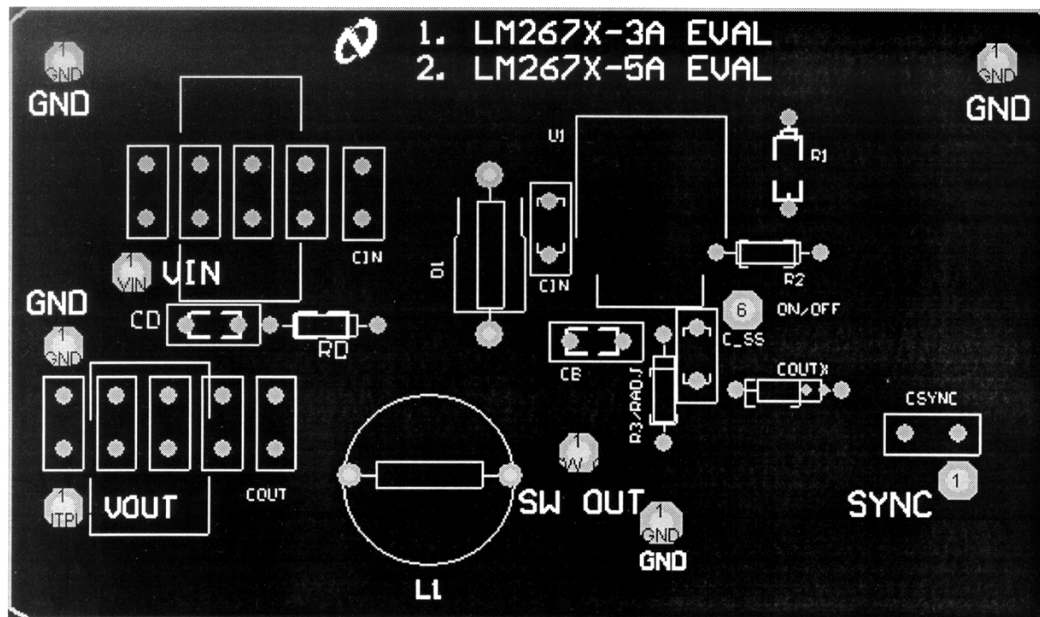

10114504

FIGURE 4. Silkscreen Image of Printed Circuit Board

Special Notes

The evaluation board was designed primarily for circuit implementation using all surface-mount components. The small series "trace inductance", particularly from the Switch Output pin, can create a high frequency (10's of MHz) ringing signal at the switch output. If problematic, this ringing can be reduced or eliminated by the use of a series RC damper or

snubber network from the switch output to ground. The addition of these components is made at the locations labeled CD and RD. Values of $0.01 \mu\text{F}$ and 10Ω are good starting values that may need to be varied depending on the magnitude of parasitic factors in a given design. In an actual end application, these components are normally not required if proper care to minimize trace lengths is taken in the PCB design.

Example Circuit Designs

Example 1: 5V/3A Converter with Surface Mount Components.

In this example, it is desired to convert a voltage range of between 8V and 12V, to 5VDC with load current of 3A. It is

also desired to implement the design with surface mount components only. Softstart duration will be set to between 1 and 1.5 ms.

Target Design Specifications

V_{IN} min.	8V
V_{IN} max.	16V
V_{OUT}	5V
I_{LOAD}	3A
I_{CL}	5.0A (approx.)
T_{SS}	1 to 1.5 ms

TABLE 3. Component Values for an 8-12V in, 5V/3A Out LM2673S-5.0 Buck Converter

Component	Value	Suggested Part Number
U1		National LM2673S-5.0
CIN	2 x 33 μ F/35V	Vishay 594D336X0035R2T
CINX	0.47 μ F	Vishay VJ1210U474ZXAA
CB	0.01 μ F/50V	Vishay VJ1206Y103MXXA
D1	3A/60V Schottky (450 mV at 3A)	Motorola MBRD360
R3*	7.15 k Ω (5.19A current limit)	Vishay CRCW12067151J
L1	22 μ H (L41)	SUMIDA ELECTRIC CO. CDRH127-220
CSS	3.3 nF/100V (softstart)	Vishay VJ1206Y33ZJXBAB
COUXTX	0.47 μ F	Vishay VJ1210U474ZXAA
COUT	2 x 180 μ F/16V	Vishay 594D187X0016R2T

Figure 5 below shows the 5V/3A design circuit. This solution is available as evaluation board **LM2673S-5_EVAL**.

Figure 6, Figure 7, Figure 8 and Figure 9 show the output waveforms for output voltage with 500 mA load, output volt-

age with 1A load, output ripple with 1A load, output voltage with 3A load, output ripple with 3A load, output response to 1A transient load and output response to 3A transient load respectively.

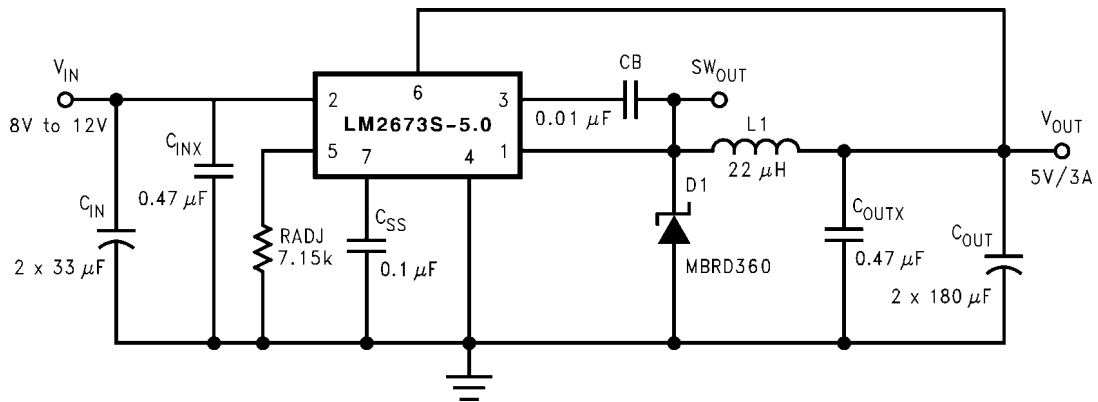

10114513

FIGURE 5. 5V/3A Design Circuit

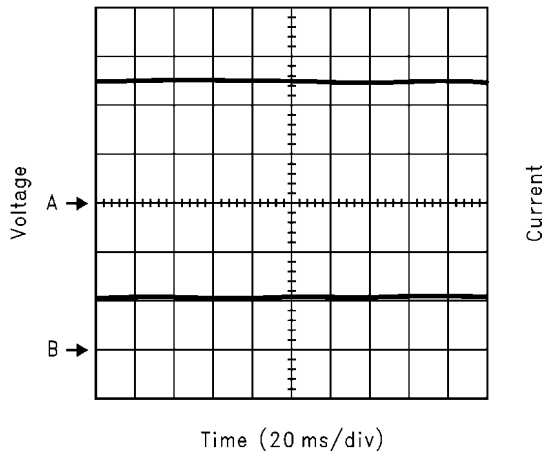

A: OUTPUT VOLTAGE: V_{OUT} ; 2V/DIV
 B: LOAD CURRENT: $I_{LOAD} = 500 \text{ mA}$; 500 mA/DIV
Output Voltage with 500 mA Load

10114505

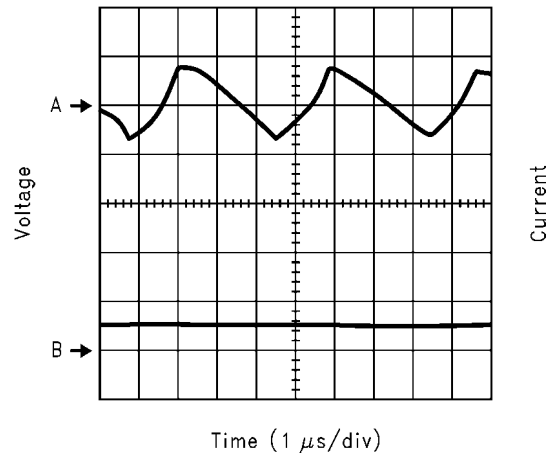

A: OUTPUT RIPPLE; 10 mV/DIV
 B: LOAD CURRENT: $I_{LOAD} = 0.5 \text{ A}$; 1A/DIV
Output Ripple with 500 mA Load

10114506

FIGURE 6. Output Voltage Waveforms with 500 mA Load

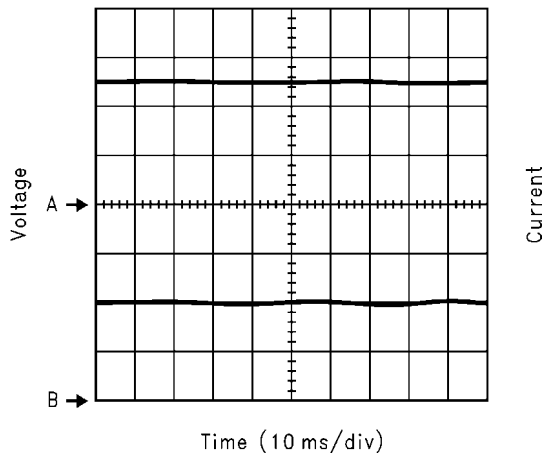

A: OUTPUT VOLTAGE: V_{OUT} ; 2V/DIV
 B: LOAD CURRENT: $I_{LOAD} = 1 \text{ A}$; 500 mA/DIV
Output Voltage with 1A Load

10114507

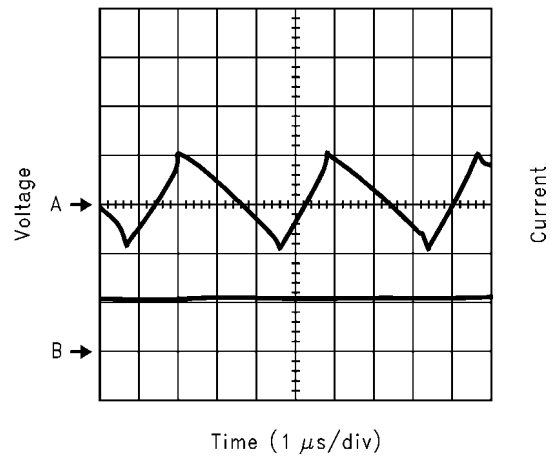

A: OUTPUT RIPPLE; 10 mV/DIV
 B: LOAD CURRENT: $I_{LOAD} = 1 \text{ A}$; 1A/DIV
Output Ripple with 1 Amp Load

10114508

FIGURE 7. Output Voltage Waveforms with 1A Load

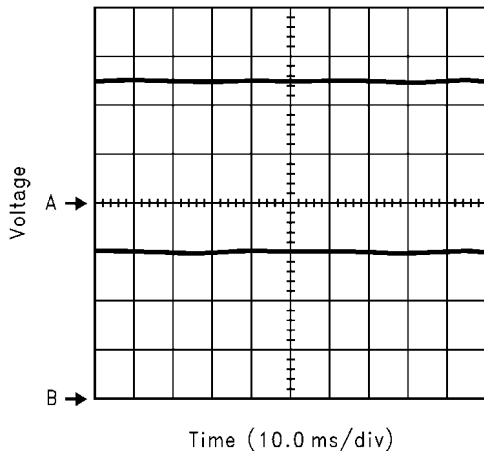

A: OUTPUT VOLTAGE: V_{OUT} ; 2V/DIV
 B: LOAD CURRENT: $I_{LOAD} = 3A$; 1A/DIV
Output Voltage with 3A Load

10114509

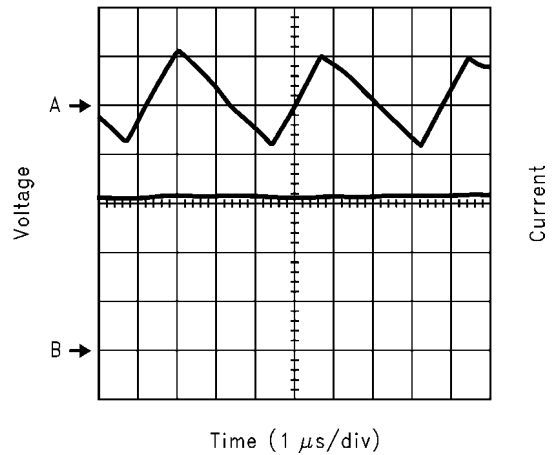

A: OUTPUT RIPPLE; 10 mV/DIV
 B: LOAD CURRENT: $I_{LOAD} = 3A$; 1A/DIV
Output Ripple with 3 Amp Load

10114510

FIGURE 8. Output Voltage Waveforms with 3 Amp Load

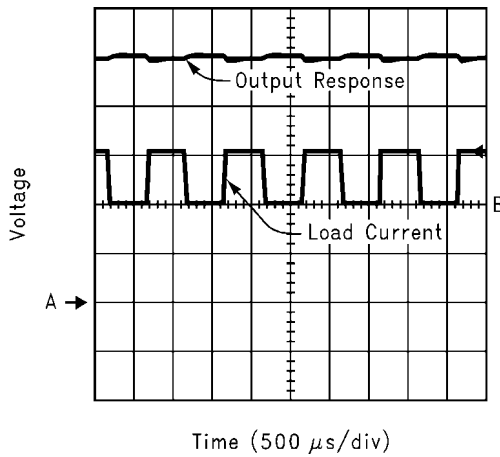

A: OUTPUT RESPONSE; 1V/DIV
 B: TRANSIENT LOAD CURRENT: 1A/DIV
Output Response to 0~1A Transient Load

10114511

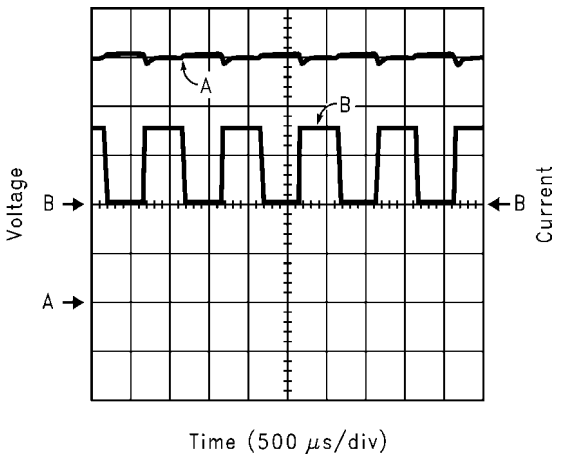

A: OUTPUT RESPONSE; 1V/DIV
 B: TRANSIENT LOAD CURRENT: 2A/DIV
Output Response to 0~3A Load Transient

10114512

FIGURE 9. Output Response To Load Transient

Example 2: 5V/5A Design with Surface Mount Components

For this example, it is desired to design a power supply to convert an input voltage within the range of 14V and 28V to an output voltage of 5V with a maximum load current of 5A using only surface mount components. In addition, the current limit of the regulator will be set to approximately 7.0A, and the softstart time will be set to approximately 1.0 ms to limit the startup surge current.

Target Design Specifications:

V_{IN} min.	14V
V_{IN} max.	28V
V_{OUT}	5V
I_{LOAD}	5A
I_{CL}	7.0A (approx.)
T_{SS}	1.0 ms (approx.)

TABLE 4. Component Values for an 14V-28V in, 5V/5A Out LM2679S-5.0 Buck Converter

Component	Value	Suggested Part Number
U1		National LM2679S-5.0
CIN	3 x 15 μ F/50V	Vishay 594D156X0050R2T
CINX	0.47 μ F	Vishay VJ1210U474ZXAA
CB	0.01 μ F/50V	Vishay VJ1206Y103ZXXA
D1	8A/35V Schottky (500 mV at 5A)	Motorola MBRD835L
R3*	4.99 k Ω (7.19A current limit)	Vishay CRCW12064991J
L1	15 μ H	Coilcraft D05022P-153
CSS	4.7 nF/100V (1.0 ms softstart)	Vishay VJ1206Y47ZJXBAB
COUX	0.47 μ F	Vishay VJ1210U474ZXAA
COU	2 x 180 μ F/16V	Vishay 594D187X0016R2T

Figure 10 below shows the circuit for the 5V/5A design. This solution is available as evaluation board **LM2679S-5_EVAL**.

Figure 11, Figure 12, Figure 13, Figure 14, and Figure 15 show the output waveforms for output voltage with 500 mA load, output voltage with 2.5A load, output ripple with 2.5A

load, output voltage with 5A load, output ripple with 5A load, output response to 500 mA transient load, output response to 2.5A transient load and output response to 5A transient load respectively.

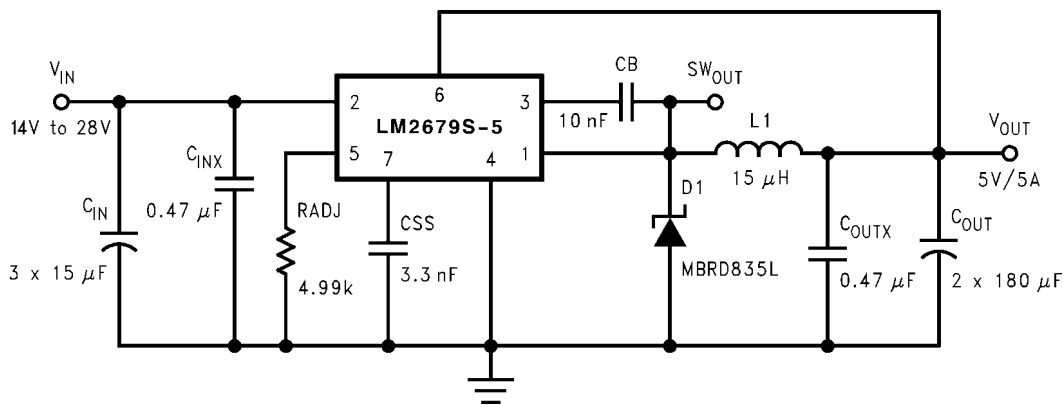

10114523

FIGURE 10. 5V/5A Design Circuit

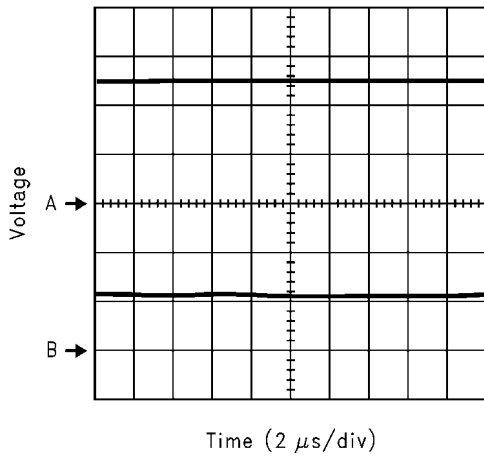

Current

Time (2 μs/div)

10114514

A: OUTPUT VOLTAGE: V_{OUT} ; 2V/DIV
 B: LOAD CURRENT: $I_{LOAD} = 500 \text{ mA}$; 500 mA/DIV

Output Voltage with 500 mA Load

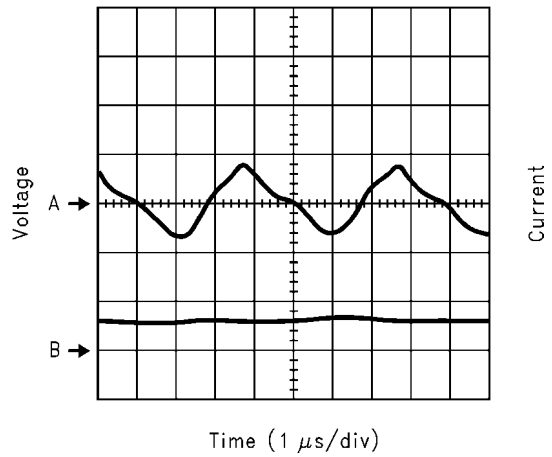

Current

Time (1 μs/div)

10114515

A: OUTPUT RIPPLE; 100 mV/DIV
 B: LOAD CURRENT: $I_{LOAD} = 500 \text{ mA}$; 1A/DIV

Output Ripple with 500 mA Load

FIGURE 11. Output Voltage Waveforms with 500 mA Load

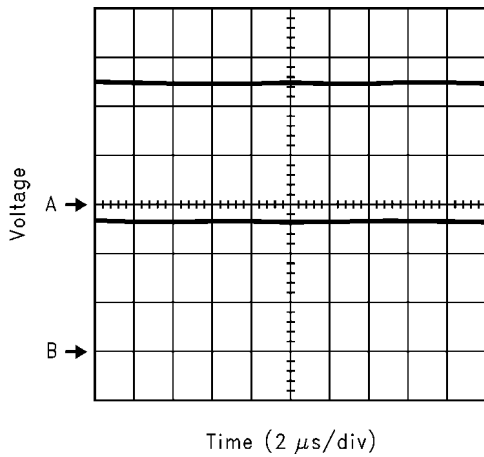

Current

Time (2 μs/div)

10114516

A: OUTPUT VOLTAGE: V_{OUT} ; 2V/DIV
 B: LOAD CURRENT: $I_{LOAD} = 2.5\text{A}$; 1A/DIV

Output Voltage with 2.5A Load

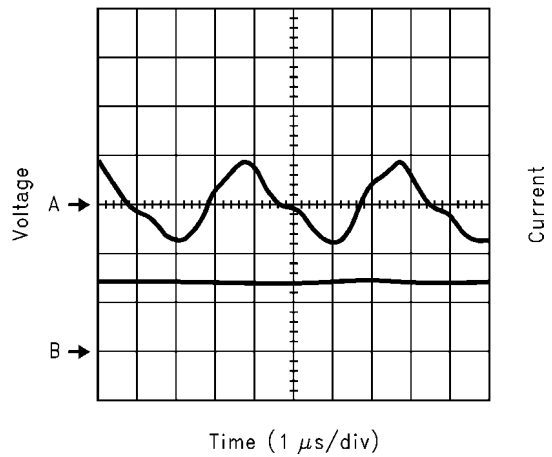

Current

Time (1 μs/div)

10114517

A: OUTPUT RIPPLE; 100 mV/DIV
 B: LOAD CURRENT: $I_{LOAD} = 2.5\text{A}$; 2A/DIV

Output Ripple with 2.5A Load

FIGURE 12. Output Voltage Waveforms with 2.5A Load

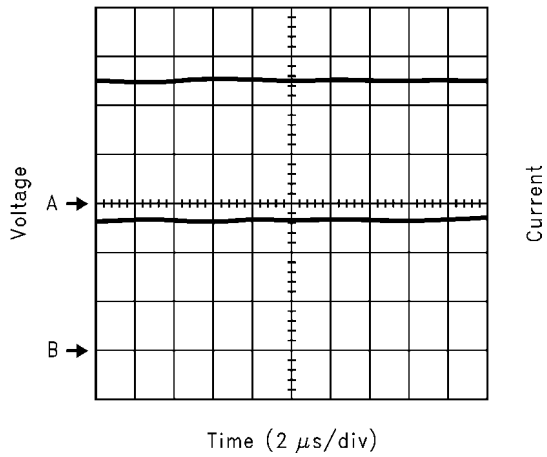

10114518

A: OUTPUT VOLTAGE: V_{OUT} ; 2V/DIV
 B: LOAD CURRENT: $I_{LOAD} = 5A$; 2A/DIV

Output Voltage with 5A Load

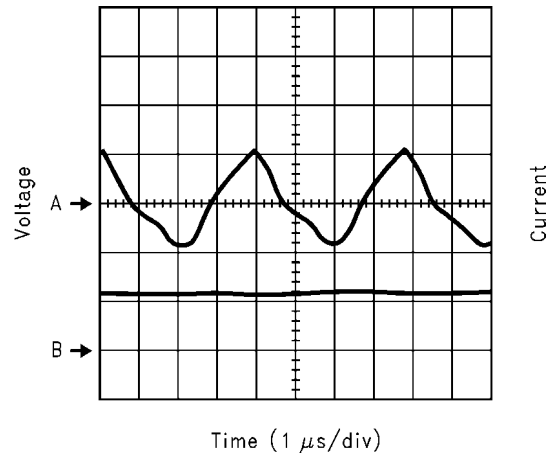

10114519

A: OUTPUT RIPPLE; 100 mV/DIV
 B: LOAD CURRENT: $I_{LOAD} = 5A$; 5A/DIV

Output Ripple with 5A Load

FIGURE 13. Output Voltage Waveforms with 5A Load

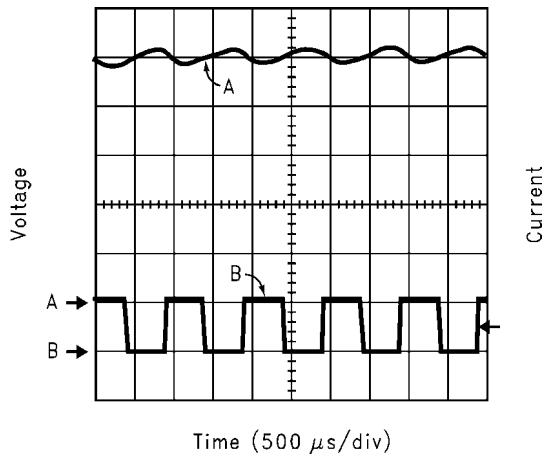

10114520

A: OUTPUT RESPONSE; 1V/DIV
 B: TRANSIENT LOAD CURRENT: 500 mA/DIV

Output Response to 0~0.5A Transient Load

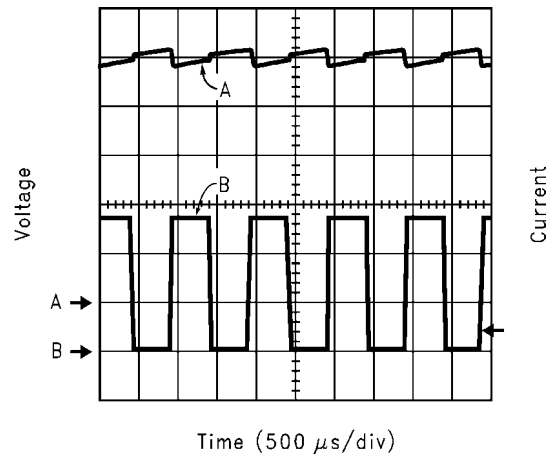

10114521

A: OUTPUT RESPONSE; 1V/DIV
 B: TRANSIENT LOAD CURRENT: 1A/DIV

Output Response to 0~2.5A Load Transient

FIGURE 14. Output Response To Load Transient

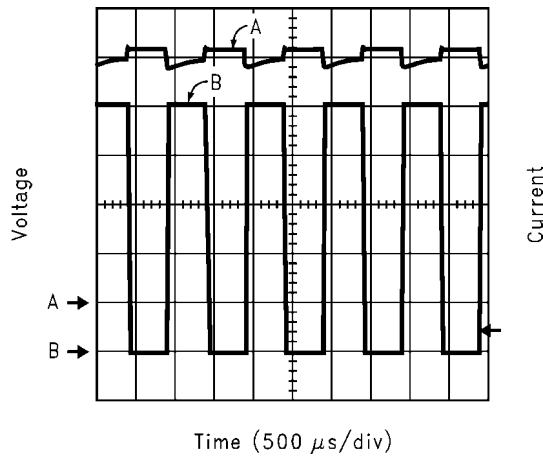

A: OUTPUT RESPONSE: 1V/DIV
 B: LOAD CURRENT: $I_{LOAD} = 1A/DIV$

10114522

FIGURE 15. Output Response to 0~5A Transient Load

Operating the Evaluation Boards

SETUP

The **LM2673S-5_EVAL** and **LM2679S-5_EVAL** evaluation boards come ready to be tested. The only setup needed is connecting the input voltage to the VIN and GND posts. The output can be taken from the VOUT post. The other signals of interest, switch output (SW out) and softstart (C_SS) posts, are clearly marked for use in checking the signal integrity. The softstart post has an ON/OFF input when this feature is being used.

OPERATING CONDITIONS

The input source for the LM267x family of regulators must be 8V or greater for proper setup and operation. The input voltage range for **LM2673S-5_EVAL** evaluation board is from 8V to 12V and the range for **LM2679S-5_EVAL** is from 14V to 28V. The maximum voltage rating of the LM267x family of regulators is 40V.

Load can be applied from 0A to the maximum for the design. Higher current above the design current limit will result in activation of the design current limit circuit. It is advisable to have a minimal load of (at least 10 mA) during startup when the input to output differential voltage is greater than 10V to prevent output ramping beyond desired value.

PCB LAYOUT OPTIMIZATION

As in any switching regulator, layout is very important. Rapidly switching currents associated with wiring inductance can generate voltage transients which can cause problems. For minimal inductance and ground loops, the printed circuit traces should be as wide and short as possible on the PCB. For best results, external components should be located as close to the switcher IC as possible using ground plane construction or single point grounding.

If **open core inductors are used**, special care must be taken as to the location and positioning of this type of inductor. Allowing the inductor flux to intersect sensitive feedback, IC groundpath and C_{OUT} wiring can cause problems.

When using the adjustable version, special care must be taken as to the location of the feedback resistors and associated wiring. Physically locate both resistors near the IC, and route the wiring away from the inductor, especially an open core type of inductor.

Notes

AN-1135

Notes

For more National Semiconductor product information and proven design tools, visit the following Web sites at:
www.national.com

Products		Design Support	
Amplifiers	www.national.com/amplifiers	WEBENCH® Tools	www.national.com/webench
Audio	www.national.com/audio	App Notes	www.national.com/appnotes
Clock and Timing	www.national.com/timing	Reference Designs	www.national.com/refdesigns
Data Converters	www.national.com/adc	Samples	www.national.com/samples
Interface	www.national.com/interface	Eval Boards	www.national.com/evalboards
LVDS	www.national.com/lvds	Packaging	www.national.com/packaging
Power Management	www.national.com/power	Green Compliance	www.national.com/quality/green
Switching Regulators	www.national.com/switchers	Distributors	www.national.com/contacts
LDOs	www.national.com/lido	Quality and Reliability	www.national.com/quality
LED Lighting	www.national.com/led	Feedback/Support	www.national.com/feedback
Voltage References	www.national.com/vref	Design Made Easy	www.national.com/easy
PowerWise® Solutions	www.national.com/powerwise	Applications & Markets	www.national.com/solutions
Serial Digital Interface (SDI)	www.national.com/sdi	Mil/Aero	www.national.com/milaero
Temperature Sensors	www.national.com/tempensors	SolarMagic™	www.national.com/solarmagic
PLL/VCO	www.national.com/wireless	PowerWise® Design University	www.national.com/training

THE CONTENTS OF THIS DOCUMENT ARE PROVIDED IN CONNECTION WITH NATIONAL SEMICONDUCTOR CORPORATION ("NATIONAL") PRODUCTS. NATIONAL MAKES NO REPRESENTATIONS OR WARRANTIES WITH RESPECT TO THE ACCURACY OR COMPLETENESS OF THE CONTENTS OF THIS PUBLICATION AND RESERVES THE RIGHT TO MAKE CHANGES TO SPECIFICATIONS AND PRODUCT DESCRIPTIONS AT ANY TIME WITHOUT NOTICE. NO LICENSE, WHETHER EXPRESS, IMPLIED, ARISING BY ESTOPPEL OR OTHERWISE, TO ANY INTELLECTUAL PROPERTY RIGHTS IS GRANTED BY THIS DOCUMENT.

TESTING AND OTHER QUALITY CONTROLS ARE USED TO THE EXTENT NATIONAL DEEMS NECESSARY TO SUPPORT NATIONAL'S PRODUCT WARRANTY. EXCEPT WHERE MANDATED BY GOVERNMENT REQUIREMENTS, TESTING OF ALL PARAMETERS OF EACH PRODUCT IS NOT NECESSARILY PERFORMED. NATIONAL ASSUMES NO LIABILITY FOR APPLICATIONS ASSISTANCE OR BUYER PRODUCT DESIGN. BUYERS ARE RESPONSIBLE FOR THEIR PRODUCTS AND APPLICATIONS USING NATIONAL COMPONENTS. PRIOR TO USING OR DISTRIBUTING ANY PRODUCTS THAT INCLUDE NATIONAL COMPONENTS, BUYERS SHOULD PROVIDE ADEQUATE DESIGN, TESTING AND OPERATING SAFEGUARDS.

EXCEPT AS PROVIDED IN NATIONAL'S TERMS AND CONDITIONS OF SALE FOR SUCH PRODUCTS, NATIONAL ASSUMES NO LIABILITY WHATSOEVER, AND NATIONAL DISCLAIMS ANY EXPRESS OR IMPLIED WARRANTY RELATING TO THE SALE AND/OR USE OF NATIONAL PRODUCTS INCLUDING LIABILITY OR WARRANTIES RELATING TO FITNESS FOR A PARTICULAR PURPOSE, MERCHANTABILITY, OR INFRINGEMENT OF ANY PATENT, COPYRIGHT OR OTHER INTELLECTUAL PROPERTY RIGHT.

LIFE SUPPORT POLICY

NATIONAL'S PRODUCTS ARE NOT AUTHORIZED FOR USE AS CRITICAL COMPONENTS IN LIFE SUPPORT DEVICES OR SYSTEMS WITHOUT THE EXPRESS PRIOR WRITTEN APPROVAL OF THE CHIEF EXECUTIVE OFFICER AND GENERAL COUNSEL OF NATIONAL SEMICONDUCTOR CORPORATION. As used herein:

Life support devices or systems are devices which (a) are intended for surgical implant into the body, or (b) support or sustain life and whose failure to perform when properly used in accordance with instructions for use provided in the labeling can be reasonably expected to result in a significant injury to the user. A critical component is any component in a life support device or system whose failure to perform can be reasonably expected to cause the failure of the life support device or system or to affect its safety or effectiveness.

National Semiconductor and the National Semiconductor logo are registered trademarks of National Semiconductor Corporation. All other brand or product names may be trademarks or registered trademarks of their respective holders.

Copyright© 2010 National Semiconductor Corporation

For the most current product information visit us at www.national.com



National Semiconductor
Americas Technical
Support Center
Email: support@nsc.com
Tel: 1-800-272-9959

National Semiconductor Europe
Technical Support Center
Email: europe.support@nsc.com

National Semiconductor Asia
Pacific Technical Support Center
Email: ap.support@nsc.com

National Semiconductor Japan
Technical Support Center
Email: jpn.feedback@nsc.com