

LM2734 Evaluation Board

National Semiconductor
Application Note 1350
Maurice Eaglin
February 2004



Introduction

The LM2734 demo board is configured to convert 5V input to 1.8V output at 1A load current using the LM2734X 1.6MHz or the LM2734Y 550kHz step down DC-DC regulator. The tiny low profile thin SOT23 package allows the demo board to be manufactured using less than 1 square inch of a 4-layer printed circuit board.

The circuit is configured with the boost diode connected to V_{IN} , and according to the datasheet, V_{IN} must not exceed the maximum operating limit of $5.5V + V_{ID2}$ using this configuration. This will ensure that the voltage between the Boost and SW pins, $V_{BOOST} - V_{SW}$, does not exceed 5.5V for proper operation. Please see the LM2734 datasheet for more information regarding this requirement.

A bill of materials below describes the parts used on this demo board. A schematic and layout have also been in-

cluded below along with measured performance characteristics. The schematics at the end of this document show how to re-configure this demo board for various input and output conditions as discussed in the LM2734 datasheet. Short or leave open the indicated connection as indicated in the schematics. The above restrictions for the input voltage are valid only for the demo board as shipped with the demo board schematic below.

Operating Conditions

$$V_{IN} = 5V$$

$$V_O = 1.8V$$

$$I_O = 1A$$

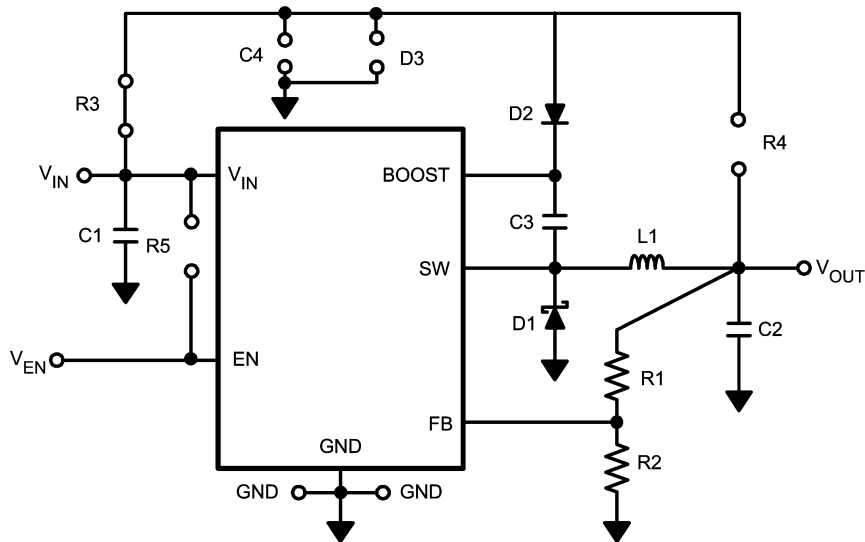

LM2734 Demo Board Schematic

20131401

Operating Conditions (Continued)

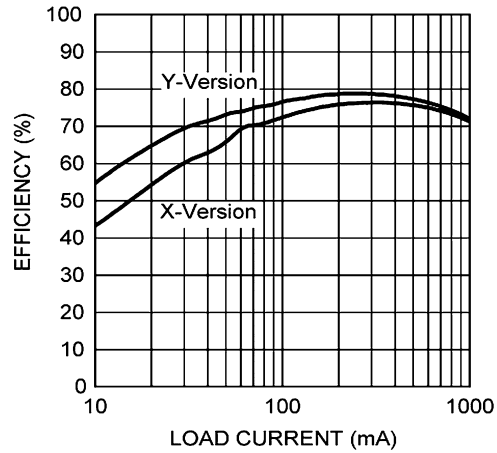

Efficiency vs Load Current

20131402

Bill of Materials X-Version

Part ID	Part Value	Manufacturer	Part Number	Package Type
C1, Input Cap	4.7 μ F, 10V, X5R	Murata	GRM42-6X5R475K10	1206
C2, Output Cap	10 μ F, 6.3V, X5R	Murata	GRM42-6X5R106K6.3	1206
C3, Boost Cap	0.01 μ F	Vishay	VJ0805Y103KXXA	0805
D2, Boost Diode	1Vf @ 50mA Diode	Diodes, Inc.	1N4148W	SOD-123
R2	10k Ω , 1%	Vishay	CRCW12061002F	1206
U1	1A Buck Regulator	National Semiconductor	LM2734X	Thin SOT23-6
D1, Catch Diode	0.34Vf Schottky 1A, 20VR	International Rectifier	MBRA120	SMA
L1	2.7 μ H, 1.8A, 22m Ω	TDK	SLF6028T-2R7M1R8	6028
R1	12.4k Ω , 1%	Vishay	CRCW12061242F	1206
R3	0 Ω	Vishay	CRCW12060R00F	1206
D3, C4, R4, R5	Open			

Bill of Materials Y-Version

Part ID	Part Value	Manufacturer	Part Number	Package Type
C1, Input Cap	10 μ F, 10V, X5R	Murata	GRM42-6X5R106K10	1206
C2, Output Cap	10 μ F, 6.3V, X5R	Murata	GRM42-6X5R106K6.3	1206
C3, Boost Cap	0.01 μ F	Vishay	VJ0805Y103KXXA	0805
D2, Boost Diode	1Vf @ 50mA Diode	Diodes, Inc.	1N4148W	SOD-123
R2	10k Ω , 1%	Vishay	CRCW12061002F	1206
U1	1A Buck Regulator	National Semiconductor	LM2734Y	Thin SOT23-6
D1, Catch Diode	0.34Vf Schottky 1A, 20VR	International Rectifier	MBRA120	SMA
L1	6.8 μ H, 1.5A, 35m Ω	TDK	SLF6028T-6R8M1R5	6028
R1	12.4k Ω , 1%	Vishay	CRCW12061242F	1206
R3	0 Ω	Vishay	CRCW12060R00F	1206
D3, C4, R4, R5	Open			

PCB Layout

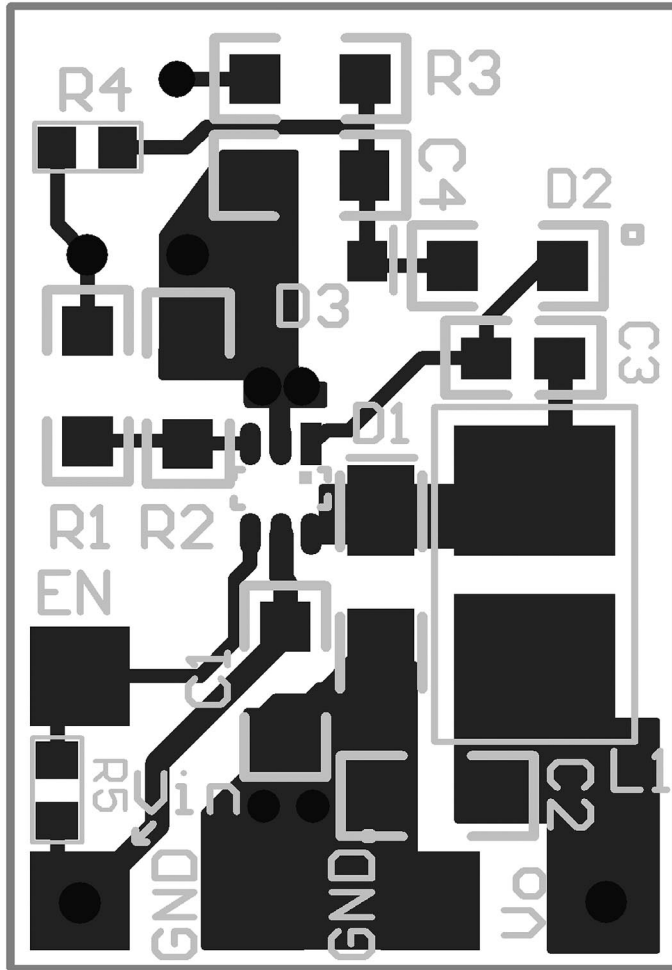

20131403

Top Layer

PCB Layout (Continued)

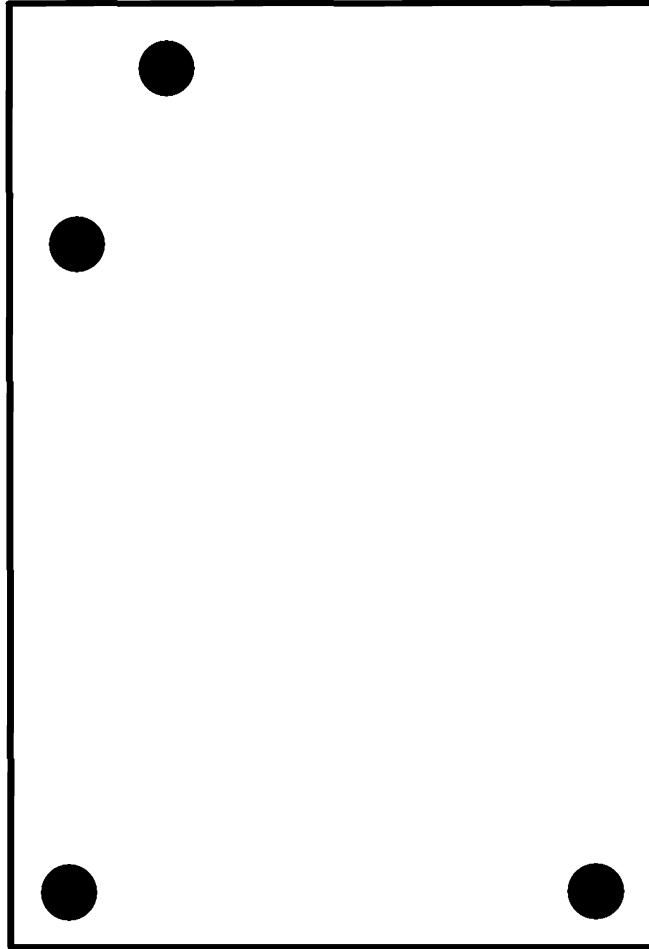

Internal Plane 1 (GND)

20131404

PCB Layout (Continued)

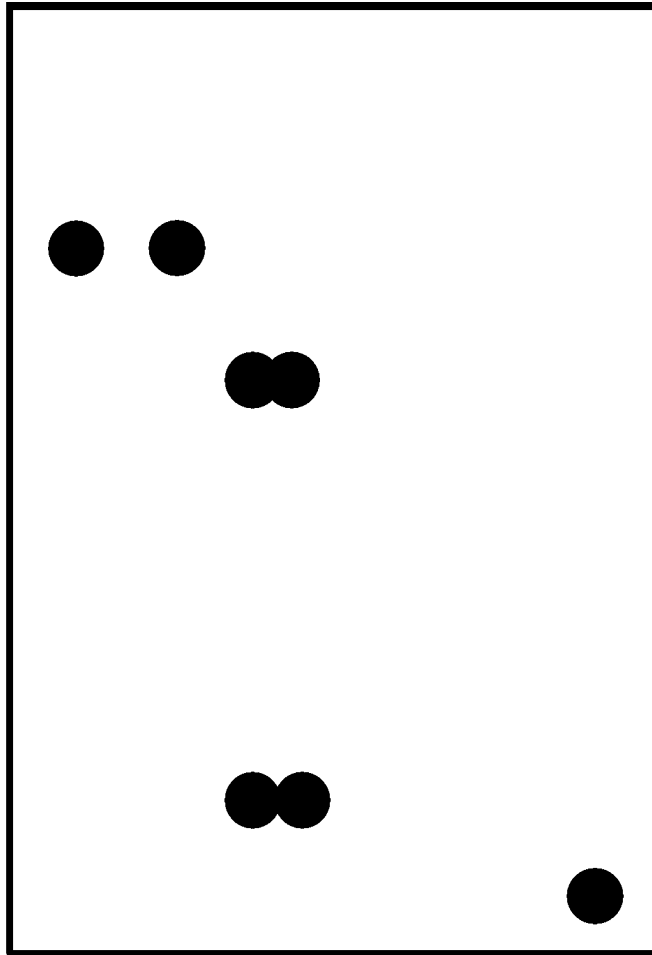

20131405

Internal Plane 2 (V_{IN})

PCB Layout (Continued)

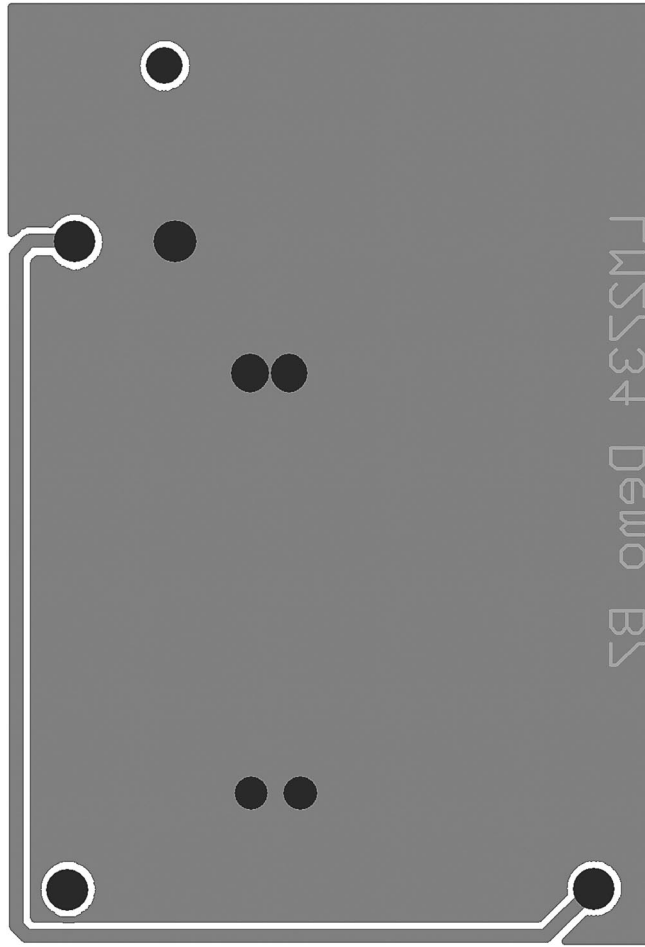

Bottom Layer

20131406

Additional Circuit Configuration Schematics

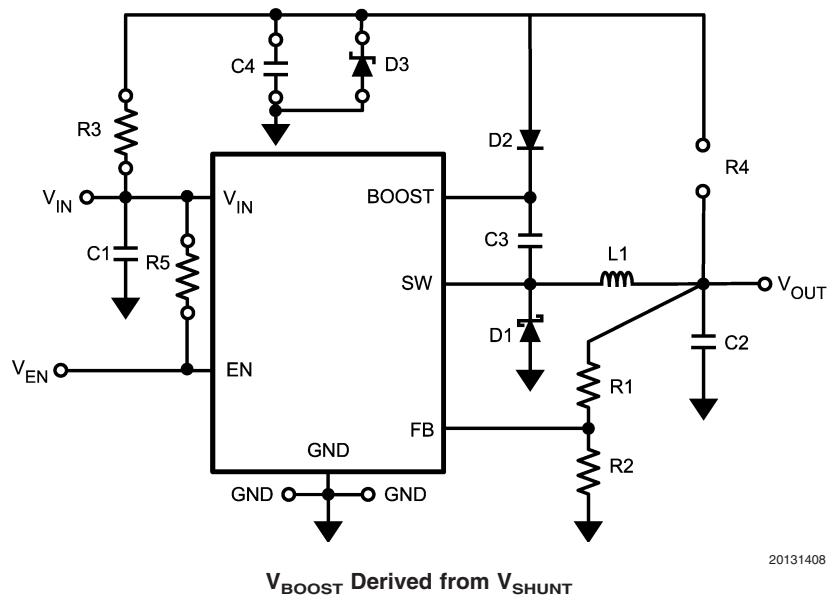
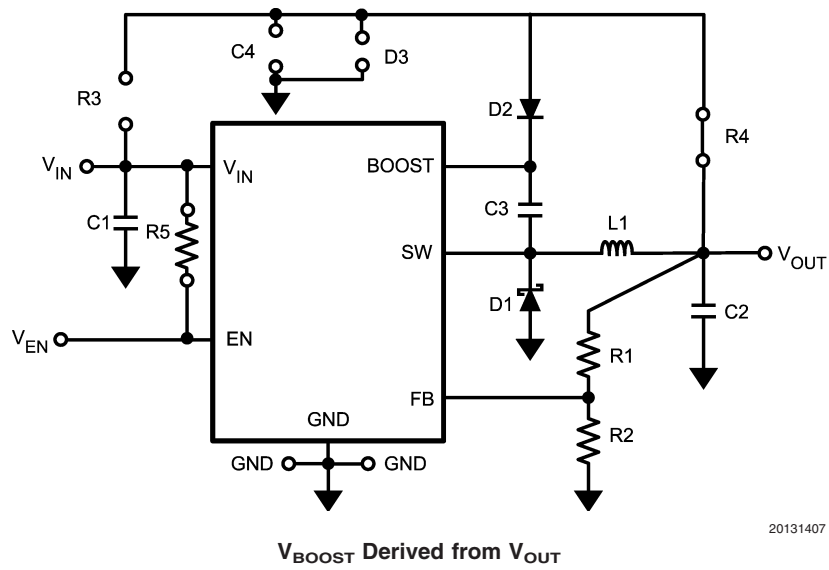

Additional Circuit Configuration Schematics (Continued)

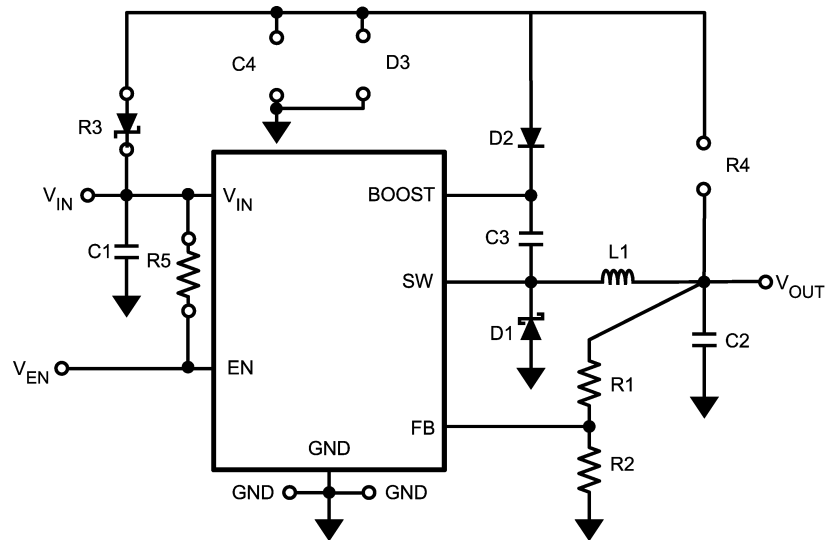

20131409

V_{BOOST} Derived from Series Zener Diode (V_{IN})

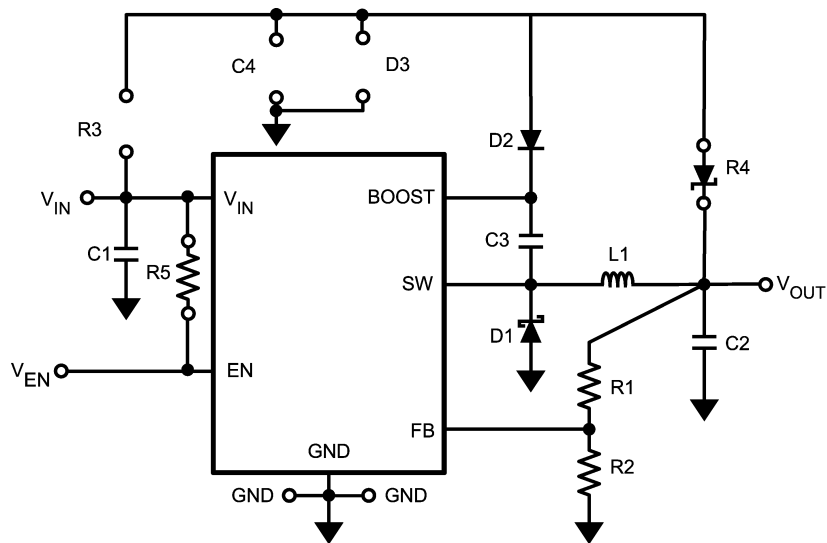

20131410

V_{BOOST} Derived from Series Zener Diode (V_{OUT})

Notes

National does not assume any responsibility for use of any circuitry described, no circuit patent licenses are implied and National reserves the right at any time without notice to change said circuitry and specifications.

For the most current product information visit us at www.national.com.

LIFE SUPPORT POLICY

NATIONAL'S PRODUCTS ARE NOT AUTHORIZED FOR USE AS CRITICAL COMPONENTS IN LIFE SUPPORT DEVICES OR SYSTEMS WITHOUT THE EXPRESS WRITTEN APPROVAL OF THE PRESIDENT AND GENERAL COUNSEL OF NATIONAL SEMICONDUCTOR CORPORATION. As used herein:

1. Life support devices or systems are devices or systems which, (a) are intended for surgical implant into the body, or (b) support or sustain life, and whose failure to perform when properly used in accordance with instructions for use provided in the labeling, can be reasonably expected to result in a significant injury to the user.
2. A critical component is any component of a life support device or system whose failure to perform can be reasonably expected to cause the failure of the life support device or system, or to affect its safety or effectiveness.

BANNED SUBSTANCE COMPLIANCE

National Semiconductor certifies that the products and packing materials meet the provisions of the Customer Products Stewardship Specification (CSP-9-111C2) and the Banned Substances and Materials of Interest Specification (CSP-9-111S2) and contain no "Banned Substances" as defined in CSP-9-111S2.



National Semiconductor
Americas Customer
Support Center
Email: new.feedback@nsc.com
Tel: 1-800-272-9959

www.national.com

National Semiconductor
Europe Customer Support Center
Fax: +49 (0) 180-530 85 86
Email: europa.support@nsc.com
Deutsch Tel: +49 (0) 69 9508 6208
English Tel: +44 (0) 870 24 0 2171
Français Tel: +33 (0) 1 41 91 8790

National Semiconductor
Asia Pacific Customer
Support Center
Email: ap.support@nsc.com

National Semiconductor
Japan Customer Support Center
Fax: 81-3-5639-7507
Email: jpn.feedback@nsc.com
Tel: 81-3-5639-7560