

LM2651_3.3V_EVAL 1.5A High Efficiency Synchronous Switching Regulator Evaluation Board

National Semiconductor
Application Note 1143
Ifeanyi Nwachukwu
July 24, 2008



Introduction

The LM2651 switching regulator provides high efficiency power conversion over a 100:1 load range (1.5A to 15mA). This feature makes the LM2651 an ideal fit in battery powered applications.

Synchronous rectification and 75 mΩ internal switches provide up to 97% efficiency. At light loads, the LM2651 enters a low power hysteretic or sleep mode to keep the efficiency high. In many applications, the efficiency still exceeds 80% at 15 mA load.

A shutdown pin is available to disable the LM2651 and reduce the supply current to 7 μA. The IC contains patented current sensing circuitry for current mode control. This feature eliminates the external current sensing required by other current mode DC to DC converters. The IC has a 300kHz fixed frequency internal oscillator. The high oscillator frequency allows the use of extremely small, low profile components.

The evaluation board can be obtained by ordering part number LM2651_3.3V_EVAL from your local National Semiconductor sales office, or National's website at www.national.com.

Evaluation Board Design

The evaluation board is designed to supply 3.3V at 15 mA up to 1.5A. The input voltage range is 4V to 14V. Components were selected based on the design procedure in the LM2651 datasheet. PCB layout is critical to reduce noise and ensure specified performance for any power supply design. To minimize the parasitic inductance in the loop of input capacitors and the internal MOSFETs, connect the capacitors to V_{IN} and PGND pins with short and wide traces. This is important because the rapidly switching current, together with wiring inductance can generate large voltage spikes that may cause noise problems. The feedback trace from the output to the feedback pin should be wide, short and kept away from the flux field of the inductor. The artwork for the evaluation board is shown at the end of this application note and the schematic shown in *Figure 1*. The parts list is given in *Table 1*. The pictorial representations of top, bottom and silkscreen layers are shown at the end of this application note.

When an undervoltage situation occurs, the output voltage can be pulled below ground as the inductor current is reversed through the synchronous FET. For applications which need to be protected from a negative voltage, a clamping diode D2 is recommended. When used, D2 should be connected cathode to V_{OUT} and anode to ground. A diode rated for a minimum of 2A is recommended.

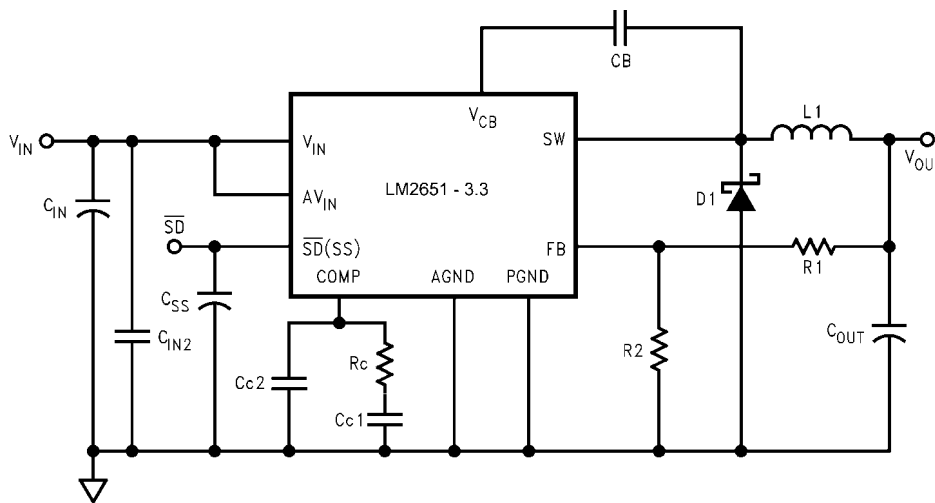

10122802

FIGURE 1. LM2651_EVAL Schematic for Adjustable Voltage

TABLE 1. Bill of Materials

Ref Designator	Part Description	Part Number
U1	IC LM2651MTC-3.3	LM2651MTC-3.3
L1	Inductor	Coilcraft DO3316P-223
CIN	Tan Cap 100 μ F 16V 10% Size = D	Vishay 594D107X0016D2T
CSS	Cer Cap 4.7 nF 50V X7R 10% 1206	Vishay VJ1206Y472KXAMB
CC2	Cer Cap 100 pF 50V NPO 1206	Vishay VJ1206A101JXAMB
CC1	Cer Cap 2.2 nF 50V X7R 10% 1206	Vishay VJ1206Y222KXAMB
COUT	Tant Cap 120 μ F 6.3V 10% Size = D	Vishay 594D127X06R3C2T
CIN2	Cer Cap 0.1 μ F 50V X7R 10% 0805	Vishay VJ0805Y104KXAMB
CB	Cer Cap 0.1 μ F 50V X7R 10% 0805	Vishay VJ0805Y104KXAMB
R1	Res 0.1 Ω 1/8W 5% LR series 0805	Vishay CRCW0805R100JTGLR
R2	Open	
RC	Res 30.0 k Ω 1/8W 5% 0805	Vishay CRCW0805303J
D1	Schottky Diode 1A SMA	Motorola MBRA130LT3

Operating the Evaluation Board

SETUP

The LM2651_3.3V_EVAL evaluation board comes ready to be tested. The only setup needed is connecting the input voltage to the V_{IN} and GND posts. The load and output are connected to the V_{OUT} post.

OPERATING CONDITIONS

The input voltage to the LM2651-3.3 regulator must be within the range of 4V to 14V DC for proper operation. The device will not function properly with voltages below 4V and damage may occur if any voltage greater than 16V is applied.

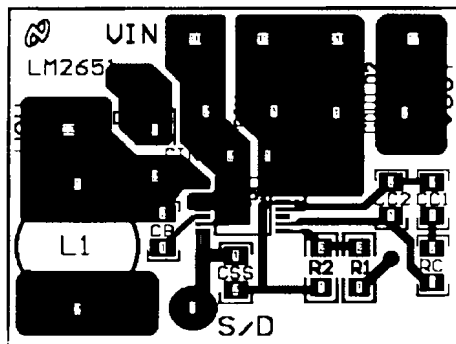

Layout Top Layer

10122807

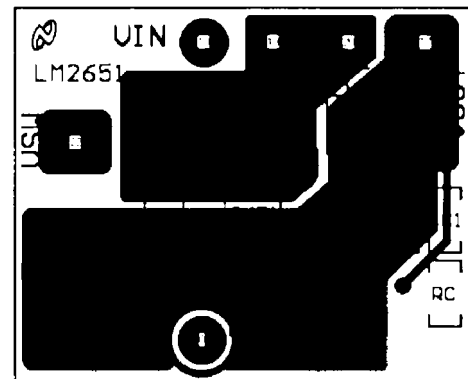

Layout Bottom Layer

10122808

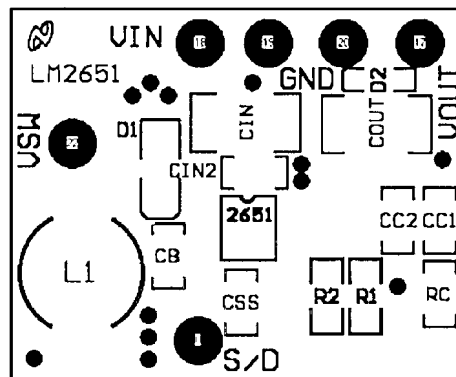

Layout Silkscreen

10122809

Notes

AN-1143

Notes

For more National Semiconductor product information and proven design tools, visit the following Web sites at:

Products		Design Support	
Amplifiers	www.national.com/amplifiers	WEBENCH	www.national.com/webench
Audio	www.national.com/audio	Analog University	www.national.com/AU
Clock Conditioners	www.national.com/timing	App Notes	www.national.com/appnotes
Data Converters	www.national.com/adc	Distributors	www.national.com/contacts
Displays	www.national.com/displays	Green Compliance	www.national.com/quality/green
Ethernet	www.national.com/ethernet	Packaging	www.national.com/packaging
Interface	www.national.com/interface	Quality and Reliability	www.national.com/quality
LVDS	www.national.com/lvds	Reference Designs	www.national.com/refdesigns
Power Management	www.national.com/power	Feedback	www.national.com/feedback
Switching Regulators	www.national.com/switchers		
LDOs	www.national.com/lido		
LED Lighting	www.national.com/led		
PowerWise	www.national.com/powerwise		
Serial Digital Interface (SDI)	www.national.com/sdi		
Temperature Sensors	www.national.com/tempsensors		
Wireless (PLL/VCO)	www.national.com/wireless		

THE CONTENTS OF THIS DOCUMENT ARE PROVIDED IN CONNECTION WITH NATIONAL SEMICONDUCTOR CORPORATION ("NATIONAL") PRODUCTS. NATIONAL MAKES NO REPRESENTATIONS OR WARRANTIES WITH RESPECT TO THE ACCURACY OR COMPLETENESS OF THE CONTENTS OF THIS PUBLICATION AND RESERVES THE RIGHT TO MAKE CHANGES TO SPECIFICATIONS AND PRODUCT DESCRIPTIONS AT ANY TIME WITHOUT NOTICE. NO LICENSE, WHETHER EXPRESS, IMPLIED, ARISING BY ESTOPPEL OR OTHERWISE, TO ANY INTELLECTUAL PROPERTY RIGHTS IS GRANTED BY THIS DOCUMENT.

TESTING AND OTHER QUALITY CONTROLS ARE USED TO THE EXTENT NATIONAL DEEMS NECESSARY TO SUPPORT NATIONAL'S PRODUCT WARRANTY. EXCEPT WHERE MANDATED BY GOVERNMENT REQUIREMENTS, TESTING OF ALL PARAMETERS OF EACH PRODUCT IS NOT NECESSARILY PERFORMED. NATIONAL ASSUMES NO LIABILITY FOR APPLICATIONS ASSISTANCE OR BUYER PRODUCT DESIGN. BUYERS ARE RESPONSIBLE FOR THEIR PRODUCTS AND APPLICATIONS USING NATIONAL COMPONENTS. PRIOR TO USING OR DISTRIBUTING ANY PRODUCTS THAT INCLUDE NATIONAL COMPONENTS, BUYERS SHOULD PROVIDE ADEQUATE DESIGN, TESTING AND OPERATING SAFEGUARDS.

EXCEPT AS PROVIDED IN NATIONAL'S TERMS AND CONDITIONS OF SALE FOR SUCH PRODUCTS, NATIONAL ASSUMES NO LIABILITY WHATSOEVER, AND NATIONAL DISCLAIMS ANY EXPRESS OR IMPLIED WARRANTY RELATING TO THE SALE AND/OR USE OF NATIONAL PRODUCTS INCLUDING LIABILITY OR WARRANTIES RELATING TO FITNESS FOR A PARTICULAR PURPOSE, MERCHANTABILITY, OR INFRINGEMENT OF ANY PATENT, COPYRIGHT OR OTHER INTELLECTUAL PROPERTY RIGHT.

LIFE SUPPORT POLICY

NATIONAL'S PRODUCTS ARE NOT AUTHORIZED FOR USE AS CRITICAL COMPONENTS IN LIFE SUPPORT DEVICES OR SYSTEMS WITHOUT THE EXPRESS PRIOR WRITTEN APPROVAL OF THE CHIEF EXECUTIVE OFFICER AND GENERAL COUNSEL OF NATIONAL SEMICONDUCTOR CORPORATION. As used herein:

Life support devices or systems are devices which (a) are intended for surgical implant into the body, or (b) support or sustain life and whose failure to perform when properly used in accordance with instructions for use provided in the labeling can be reasonably expected to result in a significant injury to the user. A critical component is any component in a life support device or system whose failure to perform can be reasonably expected to cause the failure of the life support device or system or to affect its safety or effectiveness.

National Semiconductor and the National Semiconductor logo are registered trademarks of National Semiconductor Corporation. All other brand or product names may be trademarks or registered trademarks of their respective holders.

Copyright© 2008 National Semiconductor Corporation

For the most current product information visit us at www.national.com



National Semiconductor Americas Technical Support Center
 Email: support@nsc.com
 Tel: 1-800-272-9959

National Semiconductor Europe Technical Support Center
 Email: europe.support@nsc.com
 German Tel: +49 (0) 180 5010 771
 English Tel: +44 (0) 870 850 4288

National Semiconductor Asia Pacific Technical Support Center
 Email: ap.support@nsc.com

National Semiconductor Japan Technical Support Center
 Email: jpn.feedback@nsc.com