

Wide Mains, 19 V / 8 A Power Supply Including Power Factor Correction

Prepared by: Joël Turchi,
ON Semiconductor

Introduction

When associated to forward or half-bridge converters taking advantage of a narrow input voltage range, the PFC stage should be designed to start first and to remain active as long as the power supply is plugged in. More specifically, the downstream converter turns on and operates while the output of the PFC stage is nominal. In other words, the PFC must be the master.

The NCP1605 is a Power Factor Controller especially designed to meet these requirements.

This driver features a “pfcOK” pin to enable the downstream converter when the PFC stage is ready for operation. Practically, it is in high state when the output voltage of the PFC stage is within regulation and low otherwise (fault or startup condition). In addition, the PFC stage having to remain active in light load conditions, the NCP1605 integrates the skip cycle capability to lower the standby losses to a minimum. For more information on this device, please refer to the datasheet at (<http://www.onsemi.com/PowerSolutions/product.do?id=NCP1605>).

Application Note AND8281 available at: (<http://www.onsemi.com/pub/Collateral/AND8281-D.PDF>) gives the main dimensioning criteria/equations for a NCP1605 driven application. For the sake of clarity, this process is illustrated in the following practical application:



ON Semiconductor®

<http://onsemi.com>

- AC line range: 90 V up to 265 V
- Output Voltage: 19 V/8 A
- IEC61000-3-2 Class D compliant

The goal of this application note is to give more information on the practical implementation of this application and to present the performance of the solution.

The power supply consists of two stages:

- A PFC pre-converter that provides the main converter with a stable 390 Vdc input voltage
- The main conversion stage that is a 2-switch forward operating at 133 kHz

The 2-switch forward is driven by the NCP1217A.

Housed in a SOIC-7 or PDIP-7 package, the NCP1217A eases the design of modern ac-dc adapters and offers a true alternative to UC384X-based designs. This circuit is ideal for 2-switch forward converters. It limits the duty-cycle below 50% and its current mode control topology provides an excellent input audio susceptibility and inherent pulse-by-pulse control.

In addition, when the current set point falls below a given value; e.g., when the output power demand diminishes, the IC automatically enters the so-called skip cycle mode and provides high efficiency at light loads. Because this occurs at a user adjustable low peak current, no acoustic noise takes place. For more information, please refer to <http://www.onsemi.com/PowerSolutions/product.do?id=NCP1217A>.

AND8292

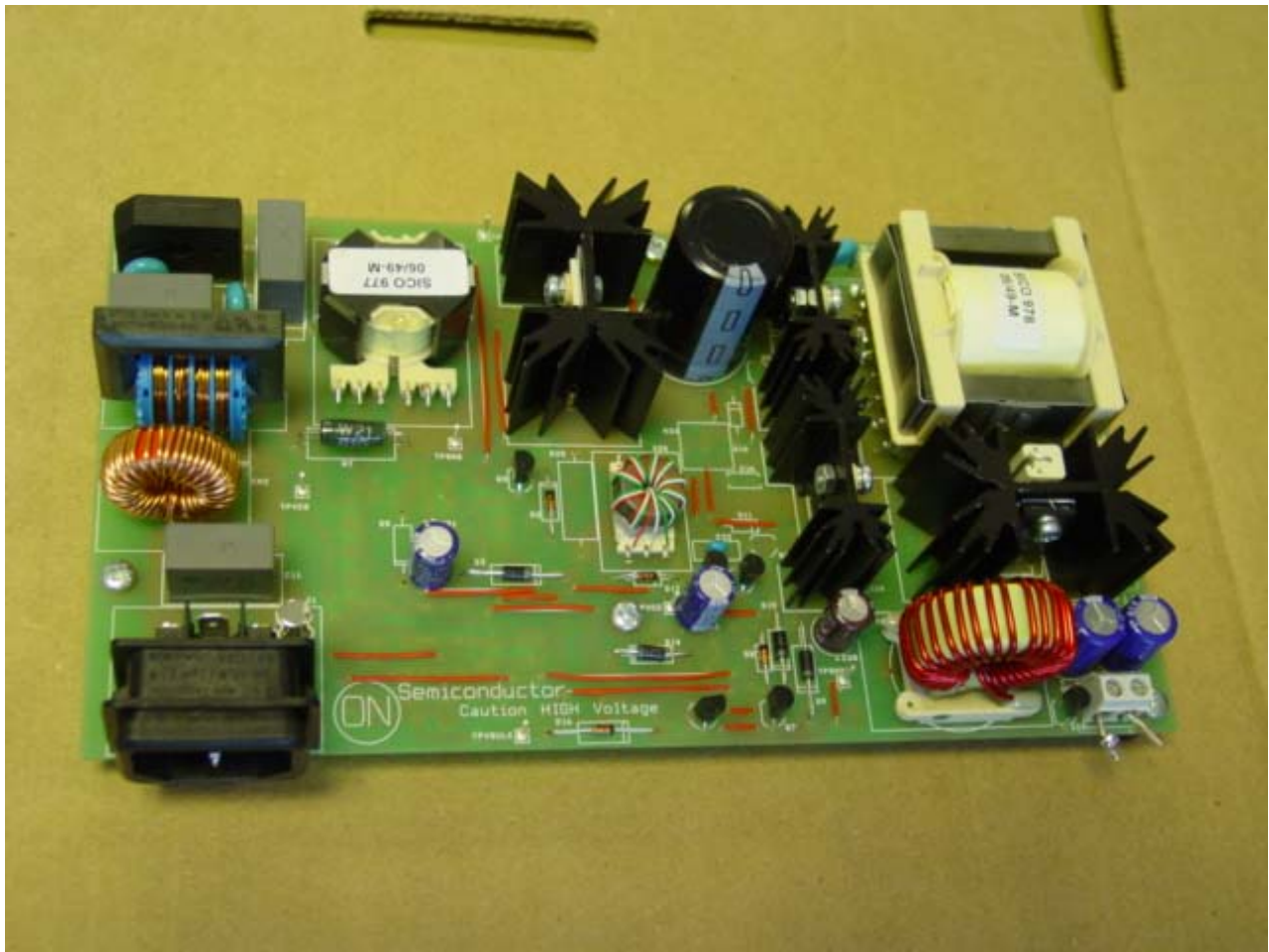

Figure 1. The Board

AND8292

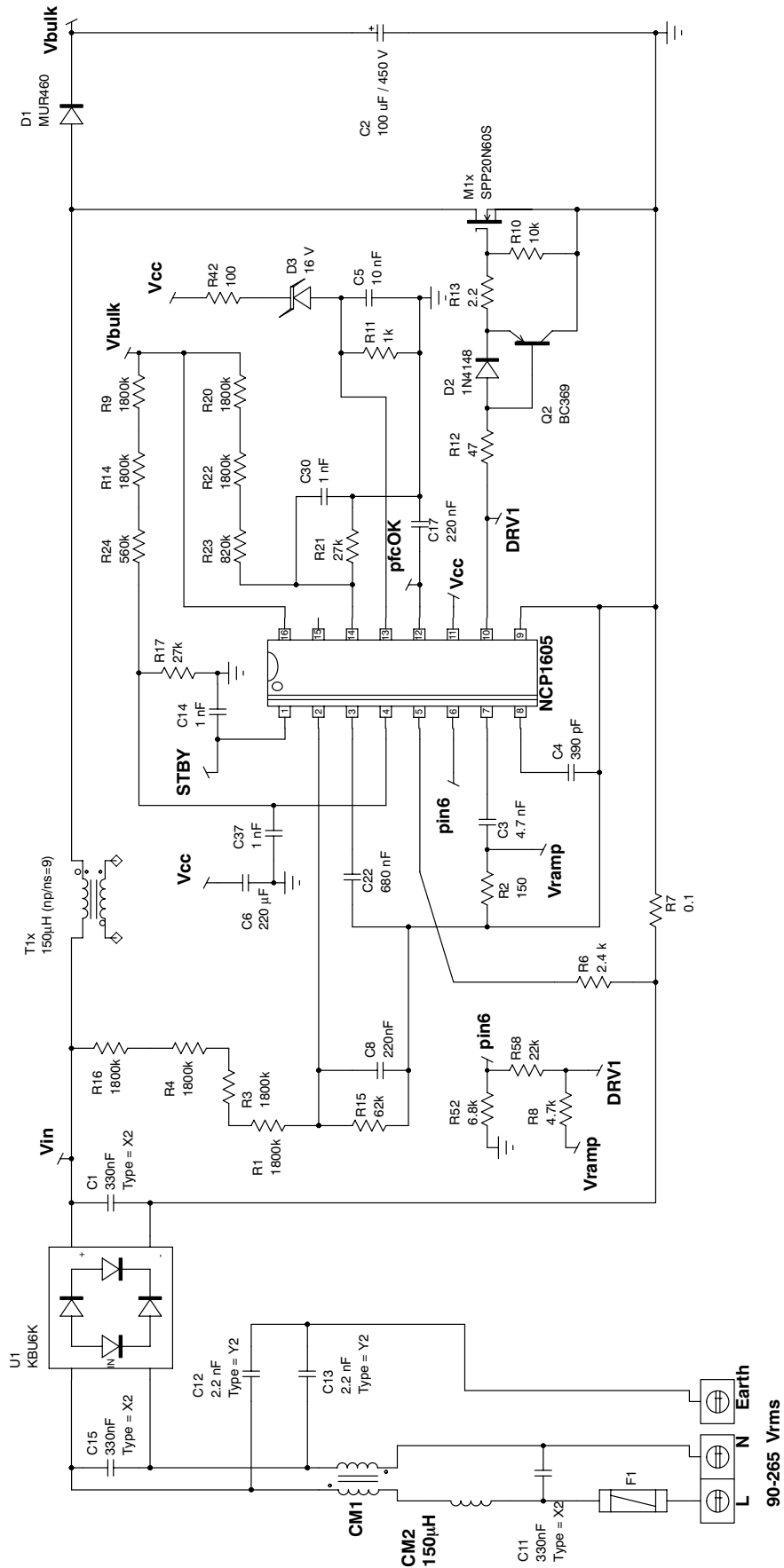

Figure 2. Application Schematic - PFC Stage

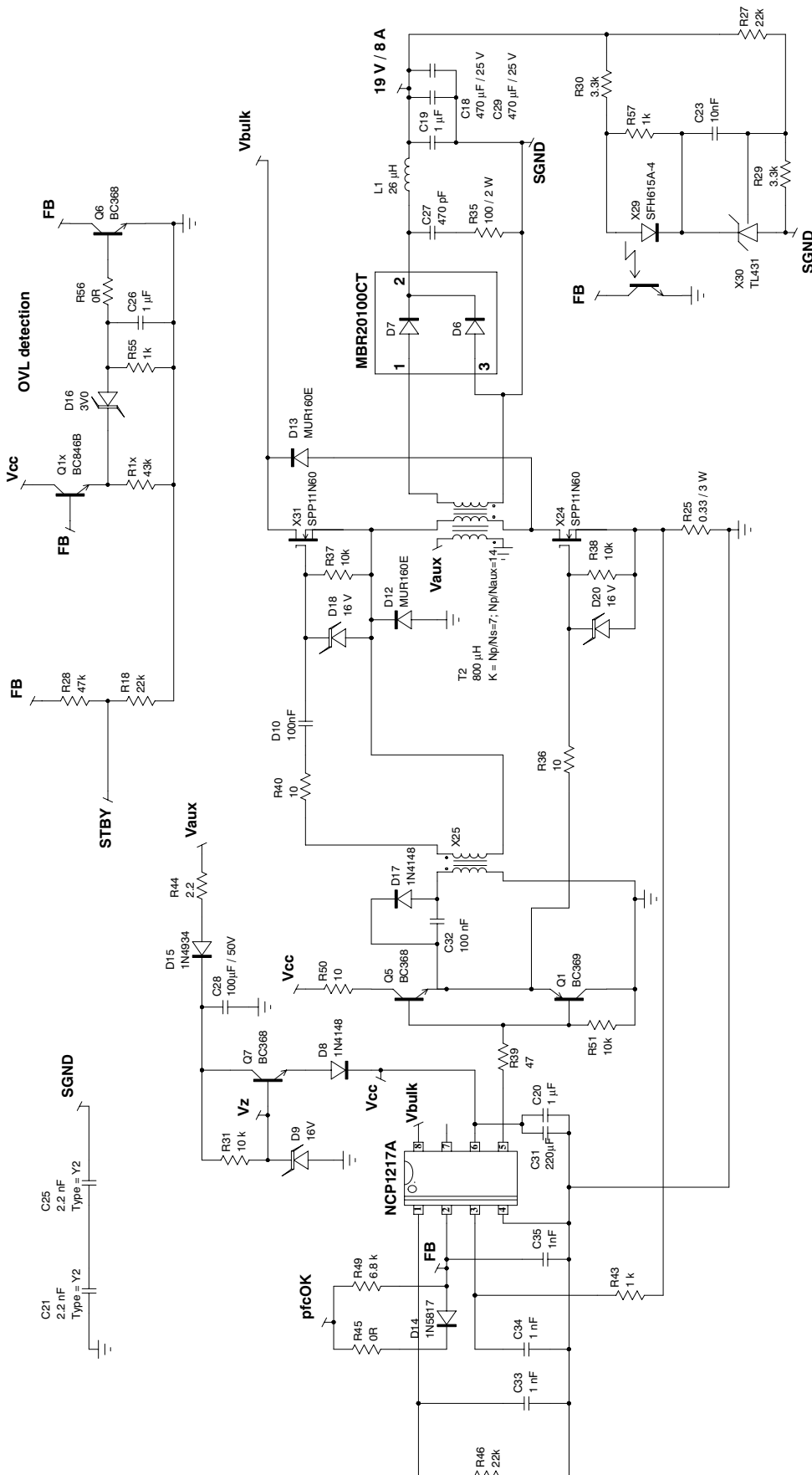

Figure 3. Application Schematic - 2 Switch Forward Converter

Note: the board is designed to also give the possibility to have the two MOSFETs of the 2-switch forward converter driven through a transformer. Some components (diodes D11, D19 and D21) that are necessary for this option, are useless in the presented version where only the high-side one is controlled through a transformer. They are short circuited in the board and, hence, they are not visible in this schematic.

AND8292

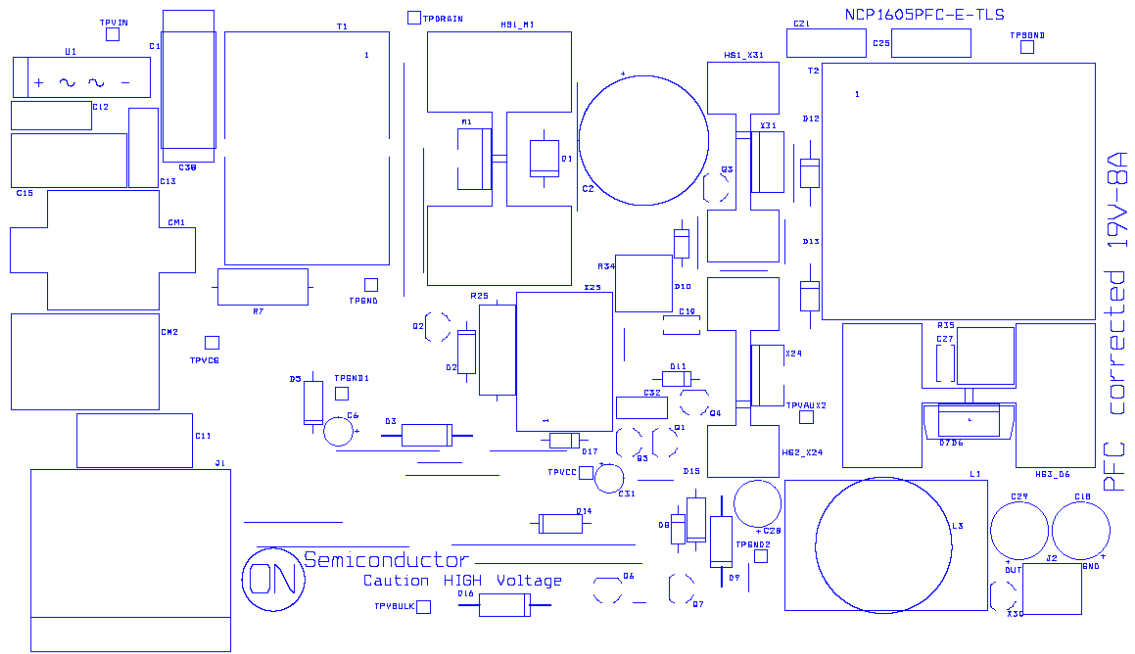

Figure 4. PCB Layout - Silkscreen Top

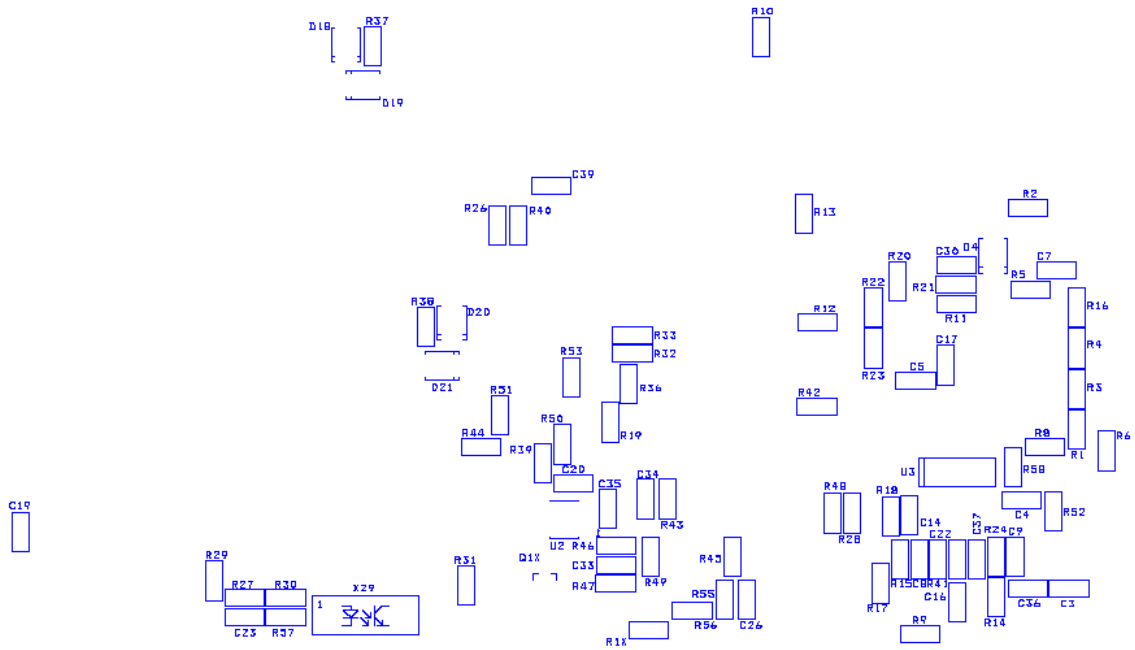

Figure 5. PCB Layout - Silkscreen Bottom

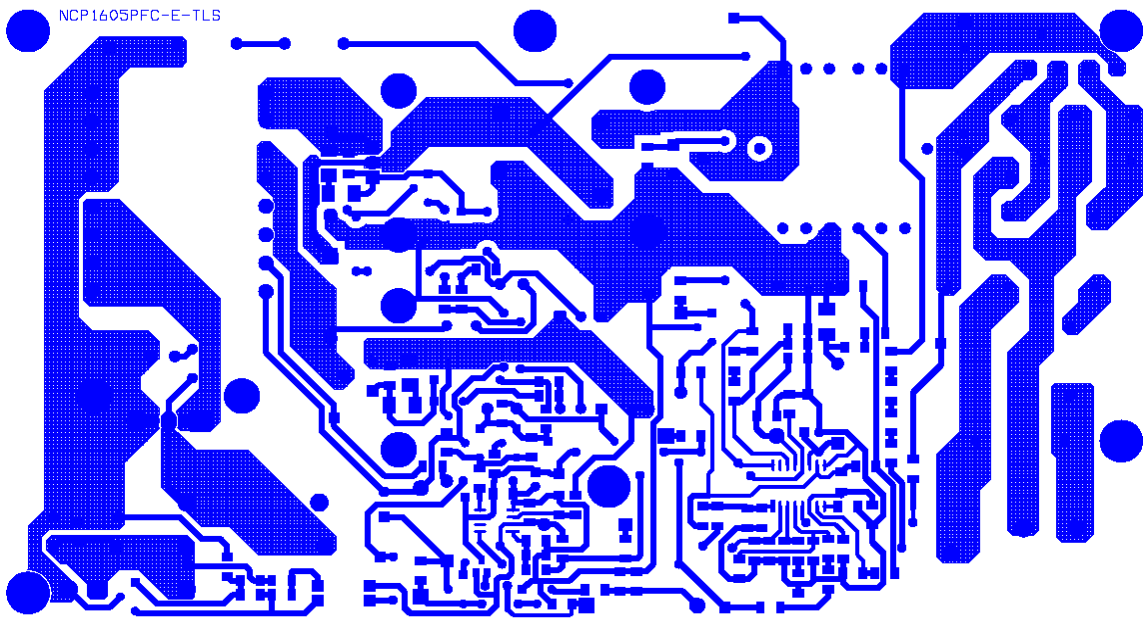
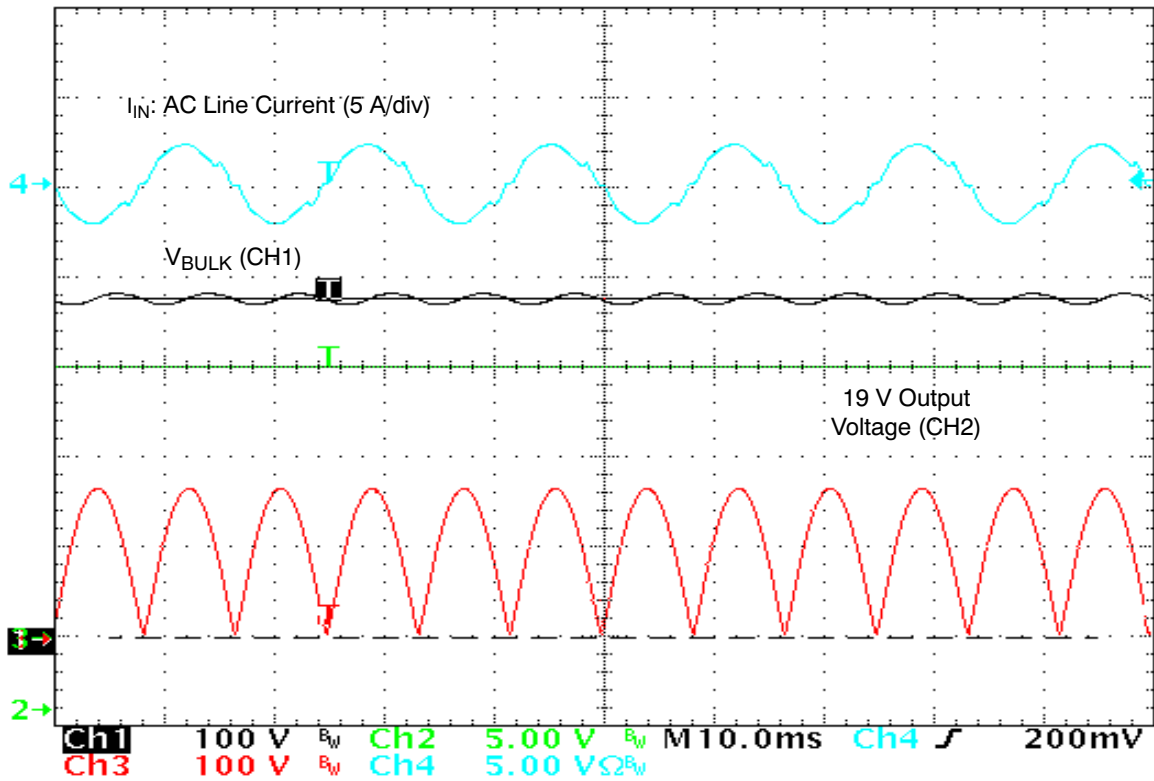
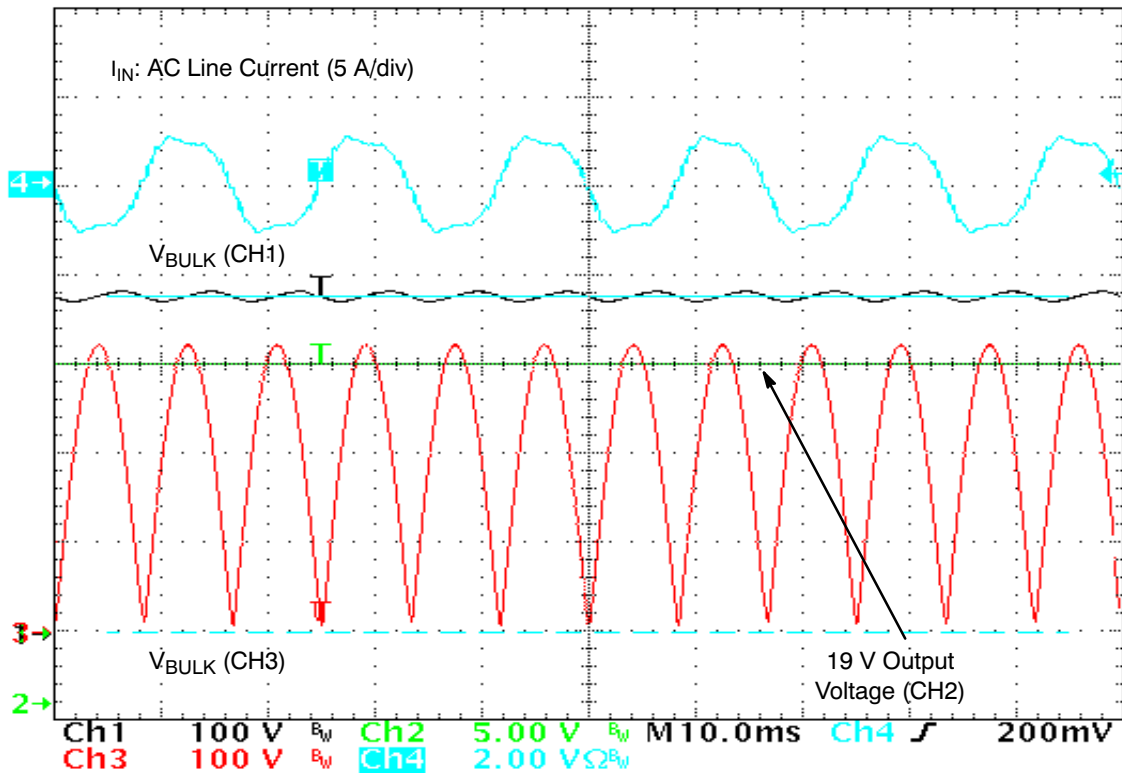

Figure 6. PCB Layout - Bottom Layer

AND8292



$V_{IN,RMS} = 120\text{ V}$, $P_{in} = 183\text{ W}$, $I_{OUT} = 8\text{ A}$, $PF = 0.992$, $THD = 10\%$



$V_{IN,RMS} = 230\text{ V}$, $P_{in} = 177\text{ W}$, $I_{OUT} = 8\text{ A}$, $PF = 0.976$, $THD = 17\%$

Figure 7. General Behavior - Typical Waveforms

AND8292

Table 1. Power Factor and Efficiency

$V_{IN, RMS}$	$P_{IN, AVG}$	PF	THD	V_{BULK}	$V_{OUT} (19 V)$	$V_{OUT} (19 V)$	Efficiency
(V)	(W)	(-)	(%)	(V)	(V)	(A)	(%)
90	28.2	0.966	24	381	19.23	1.00	68.2
90	70.5	0.991	13	381	19.23	3.00	81.8
90	114.5	0.995	9	381	19.23	5.00	84.0
90	183.2	0.990	13	363	19.23	8.00	83.9
120	27.7	0.961	20	381	19.23	1.00	69.4
120	70.3	0.987	13	381	19.23	3.00	81.1
120	113.2	0.992	11	381	19.23	5.00	83.9
120	180.3	0.997	10	381	19.23	8.00	85.3
230	28.0	0.806	28	381	19.23	1.00	68.7
230	69.2	0.940	20	381	19.23	3.00	83.4
230	112.0	0.966	18	381	19.23	5.00	85.8
230	177.4	0.976	17	381	19.23	8.00	86.7
265	27.8	0.696	52	389	19.23	1.00	69.2
265	68.6	0.901	26	381	19.23	3.00	84.1
265	111.9	0.950	21	381	19.23	5.00	85.9
265	176.9	0.950	28	381	19.23	8.00	86.9

*At full load, the efficiency remains above 83.9%.

Startup Sequencing at 120 Vrms and $I_{OUT} = 8\text{ A}$

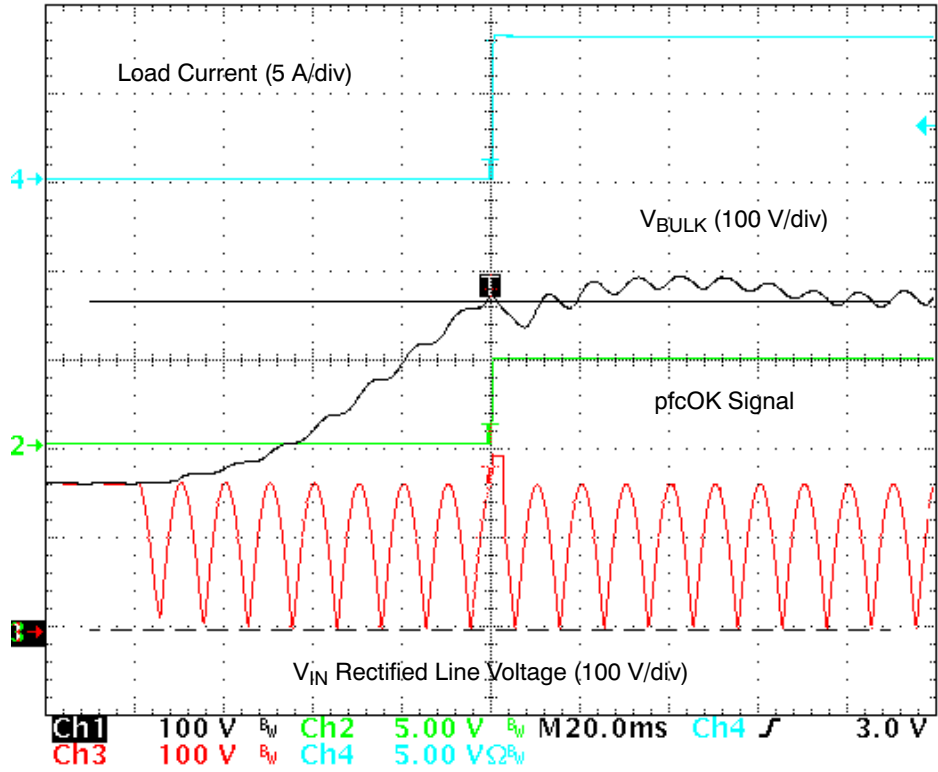

Figure 8. Startup Phase at 120 Vrms and $I_{OUT} = 8\text{ A}$

When the PFC output voltage (V_{BULK}) reaches its nominal voltage (about 382 V), the circuit detects the end of

the startup phase. The «pfcOK» pin turns high allowing the downstream converter operation.

AND8292

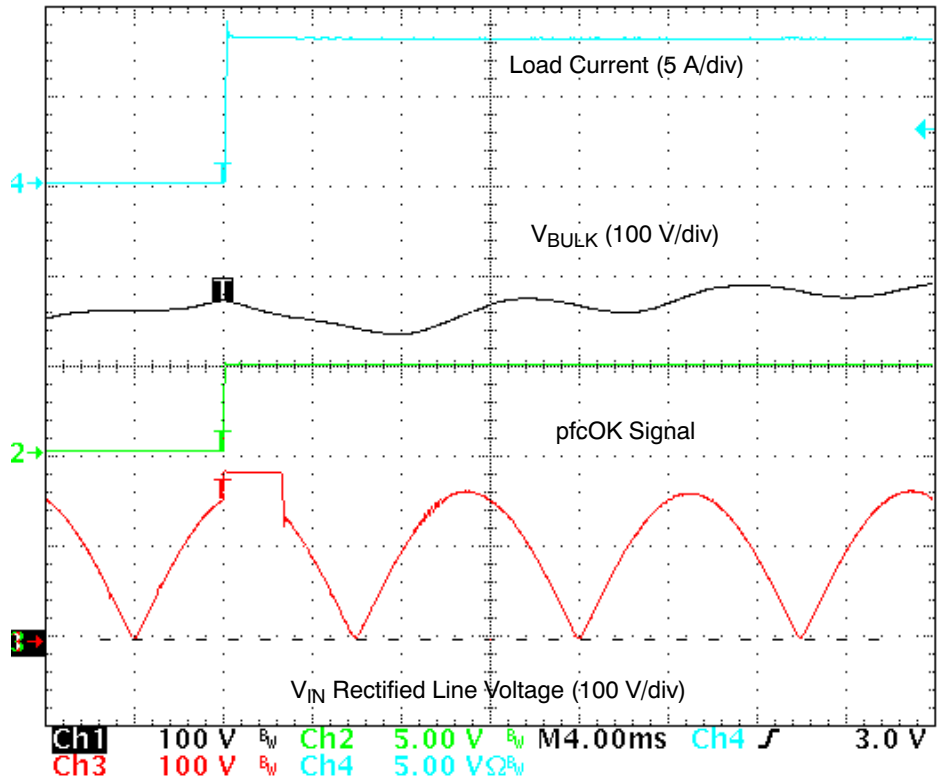

Figure 9. Zoom of the Precedent Plot

We can note some skipping sequence that takes place after «pfcOK» has turned high. This is because the NCP1605 standby management block is controlled by the feedback signal of the main converter. The PFC stage recovers activity

as soon as V_{BULK} has dropped below 95.5% of its nominal level. This behavior avoids any overshoot during the startup sequence from occurring.

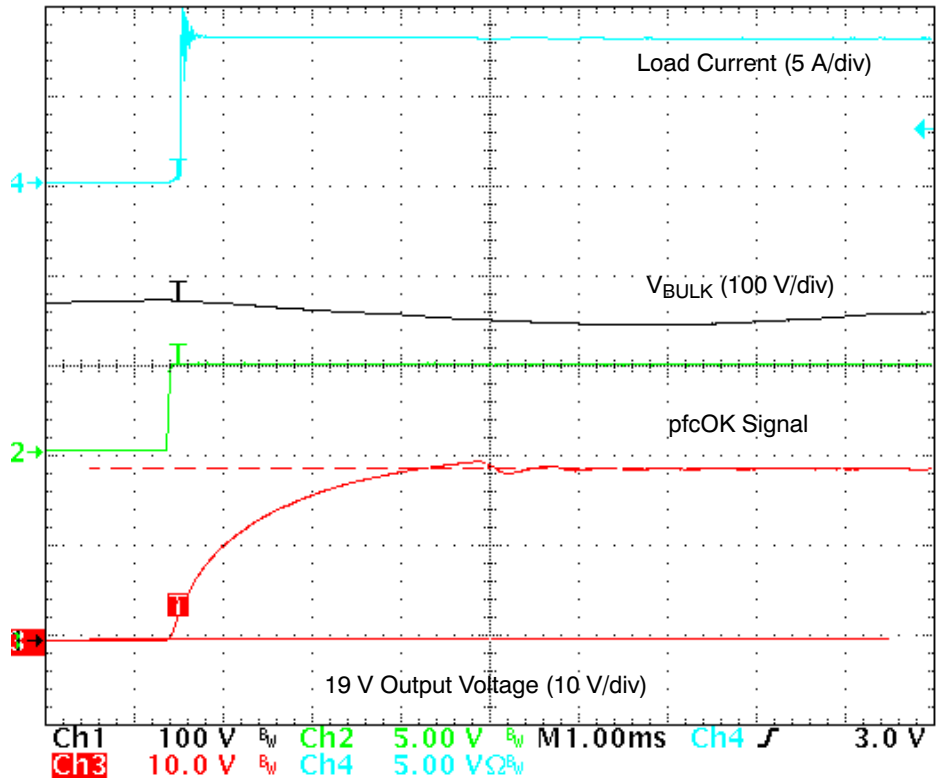

Figure 10. Startup Phase at 120 Vrms

Compared to the precedent one, Figure 10 further shows the 19 V output.

Overload / Short Circuit Protections

The application embeds a circuitry (see Figure 13) to detect overload conditions. A buffer (Q1x) builds a low impedance signal that is linearly dependent of the feedback pin of the forward controller. The OVL circuitry monitors this voltage and if it exceeds 3 V, the npn transistor Q3 turns on and disables the discrete regulator that powers the two controllers.

This circuitry protects the circuit in case of short circuit on the 19 V output. In this situation, the power supply enters a low duty-cycle, safe hiccup mode as shown by Figure 11. Figure 12 that zooms Figure 11 shows that the circuit operates over about 130 ms on a 3 s hiccup period (4% duty-cycle).

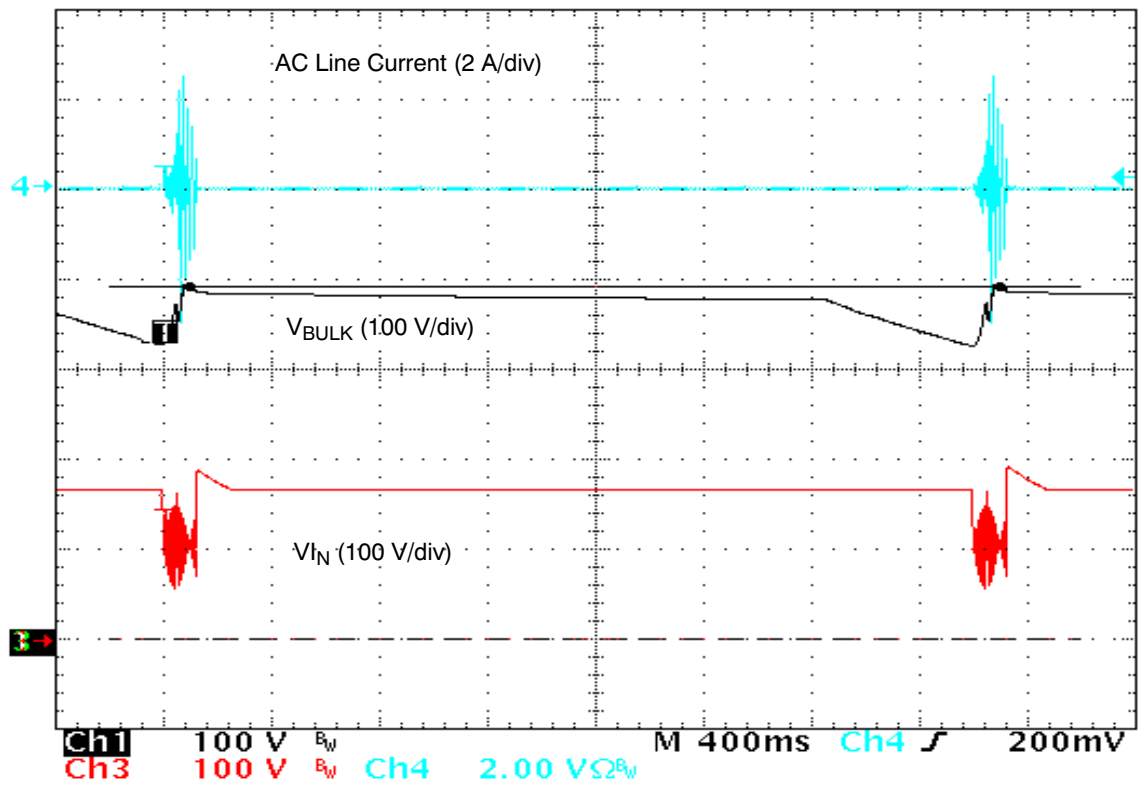

Figure 11. The Circuit Enters a Safe Low Duty-Cycle Hiccup Mode if the 19 V Output is Short Circuited (Test Made at 120 V_{RMS})

AND8292

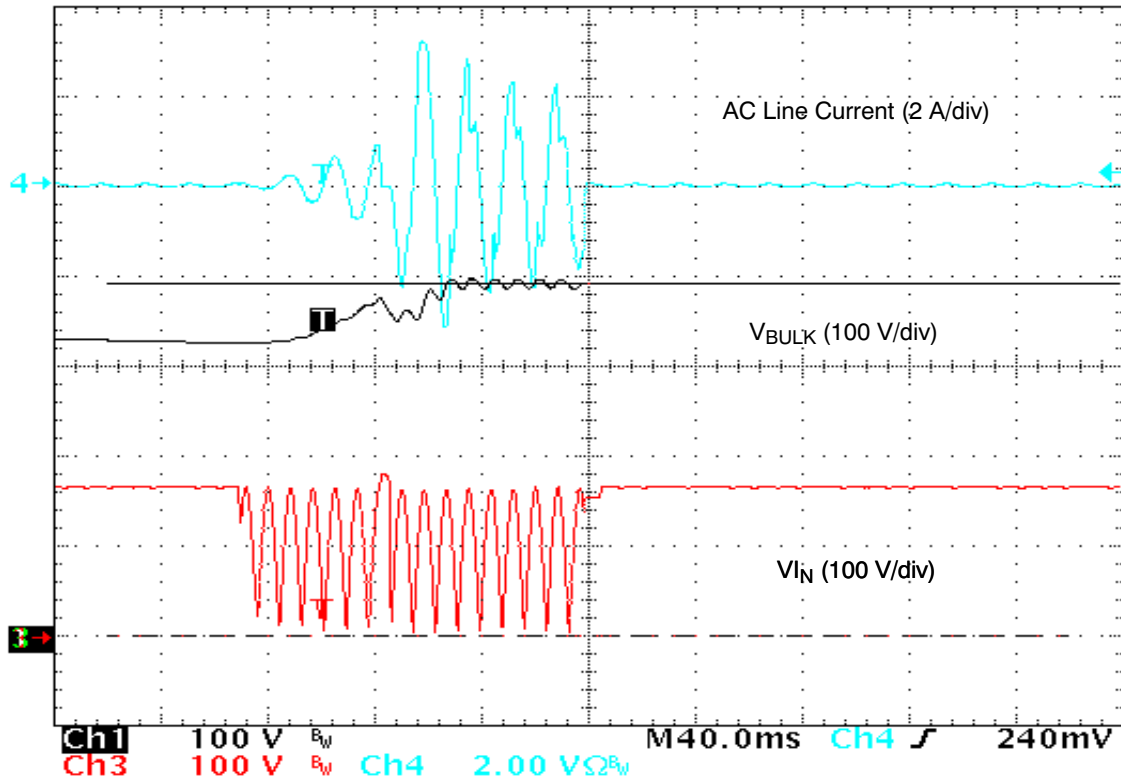

Figure 12. Zoom of the Precedent Plot

More generally, this protection triggers when the load current (I_{OUT}) is excessive. The following thresholds were measured:

Table 2.

$V_{IN, RMS}$	(V)	90	110	180	230	265
I_{OUT}	(A)	10.0	11.3	11.2	11.2	11.2

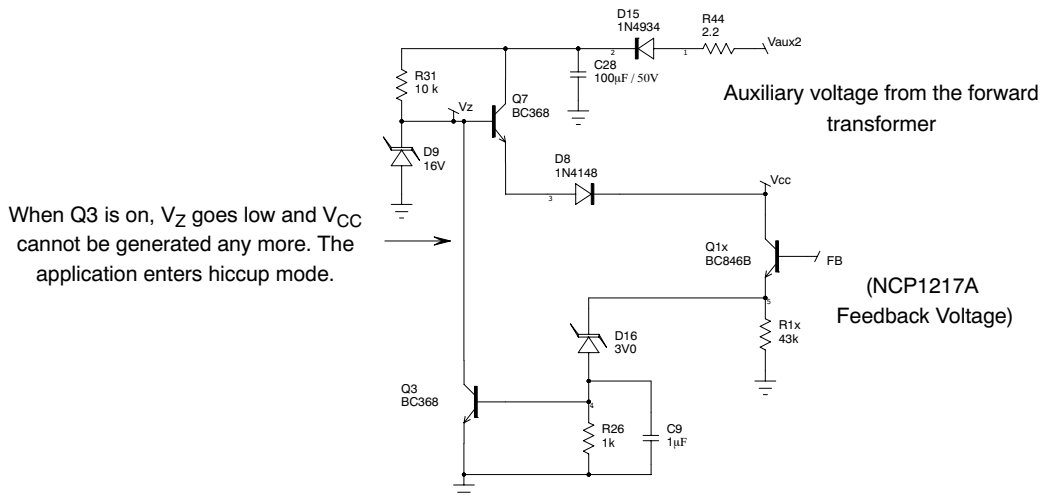

Figure 13. Circuit for Overload Protection

Protection of the PFC Stages

The NCP1605 protection features allow the design of very rugged PFC stages:

- The following brownout detection levels were measured (the 19 V output being loaded by a 5 A current):
 - Minimum line RMS voltage to start operation: 83 V.
 - RMS line voltage being which the system stops operation: 74 V.
- As shown by Figure 14, the line current is limited to 3.2 A. This corresponds to proper expected level with $R_{OCP} = 2.4 \text{ k}\Omega$:

$$(I_{LINE,MAX}) = \frac{R_{OCP} \cdot I_{REF}}{2 \cdot R_{SENSE}} = \frac{2.4 \text{ k} \cdot 250 \mu\text{A}}{2 \cdot 0.1} = 3 \text{ A}$$

- Pin 14 monitors a portion of the output voltage and stops the circuit switching as long as the pin14 voltage exceeds 2.5 V. This overvoltage protection (OVP) guarantees that the bulk voltage cannot exceed the set OVP level (about 410 V here).
- The undervoltage that is also attached to pin 14, detects if the OVP pin is accidentally grounded or if one of the upper resistors is not correctly connected and prevents the circuit operation in case of such a fault. Ultimately,

this protection avoids the power supply destruction if there is a failure in the OVP sensing network.

- Shut-down: if more than 2.5 V are applied to pin 13, the circuit latches off and cannot recover operation until the SMPS is unplugged (to enable the NCP1605 V_{CC} voltage to drop below its 4 V reset voltage). This lathoff capability is supposed to trigger in case of a major fault like any overheating of the SMPS. In this application, it is used to disable the power supply in case of a severe runaway of the V_{CC} voltage. This is simply made by applying the V_{CC} voltage through a 16 V zener diode (D3) so that if $(V_{CC}-16 \text{ V})$ exceeds 2.5 V, the circuit latches off (see Figure 2). R11 adjusts the biasing current through D3 and together with R42 and C5, this resistor avoids that the protection falsely triggers due to some noise. R42 is chosen small compared to R11 not to modify the threshold since the actual voltage applied to pin 13 is:

$$\frac{R11}{R11 + R42} \cdot (V_{CC} - V_{D3}),$$

which is closed to

$$(V_{CC} - 16 \text{ V})$$

if R42 is small compared to R11 and if D3 is properly biased.

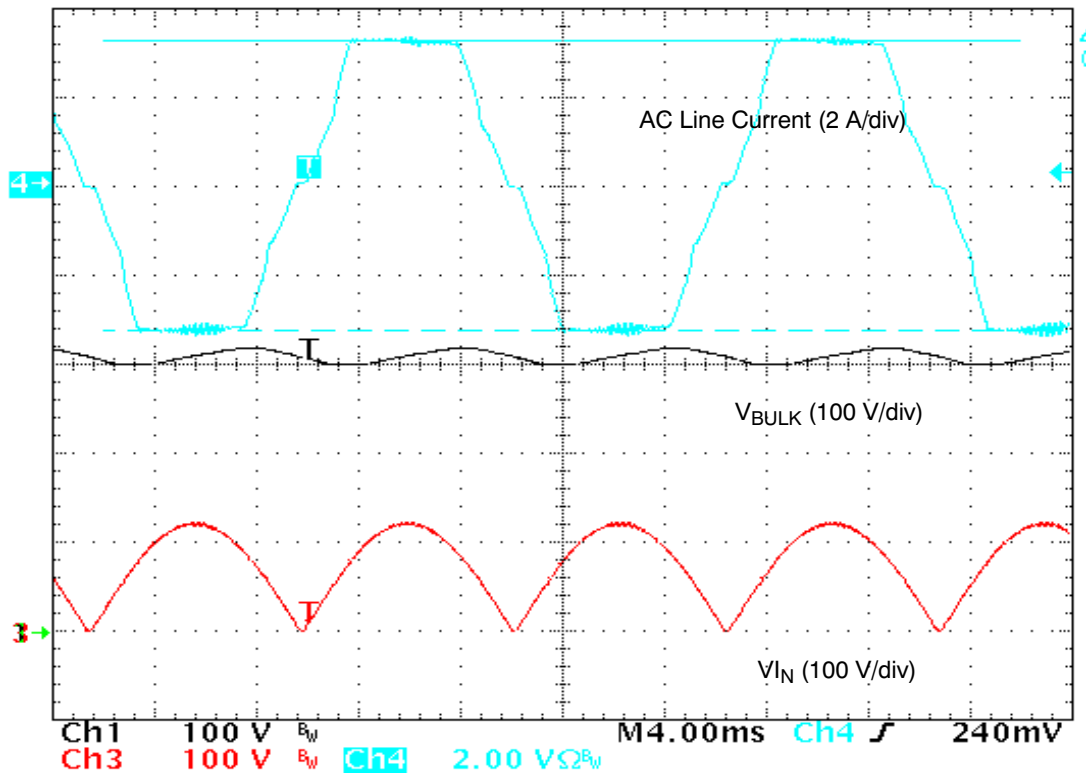

Figure 14. Action of the Overcurrent Limitation
(This Test was Made by Creating an Overload Condition at 90 Vrms).

Dynamic Performance

The following plots were obtained by varying I_{OUT} from 2 A to 8 A (slope 2 A/ μ s) at 120 Vrms.

One can note that thanks to the NCP1605 dynamic response enhancer, the bulk voltage stays largely above

350 V while the load current suddenly increases from 25% to full load (see Figure 16).

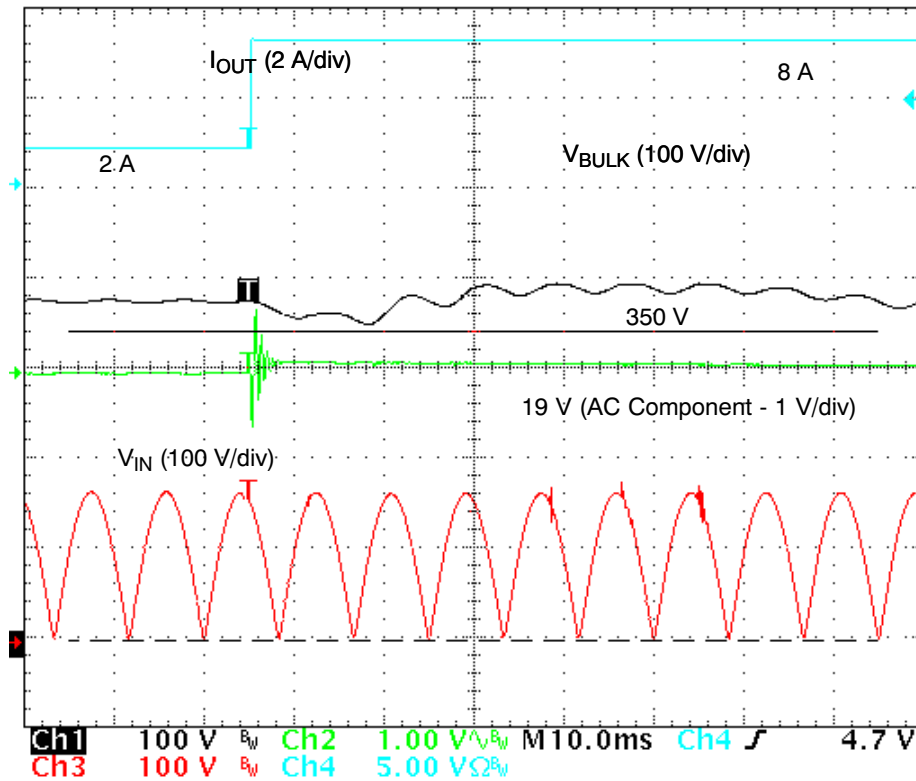

Figure 15. Abrupt Load Increase at 120 Vrms

Another interesting behavior is the absence of overshoot on V_{BULK} when the load current suddenly drops. The PFC stage takes benefit from the fast response of the 2-switch forward feedback voltage (FB). More specifically, an abrupt load decrease results in a rapid drop of the FB voltage. If this signal that controls the NCP1605 skip mode activity drops

to a level that is low enough, the PFC stage skips cycles until the bulk voltage reaches 95.5% of its nominal value. This skipping period (see the V_{BULK} decay period from 381 V down to 360 V in Figure 11) avoids any overshoot and helps provide the 2-switch forward with a narrow input voltage.

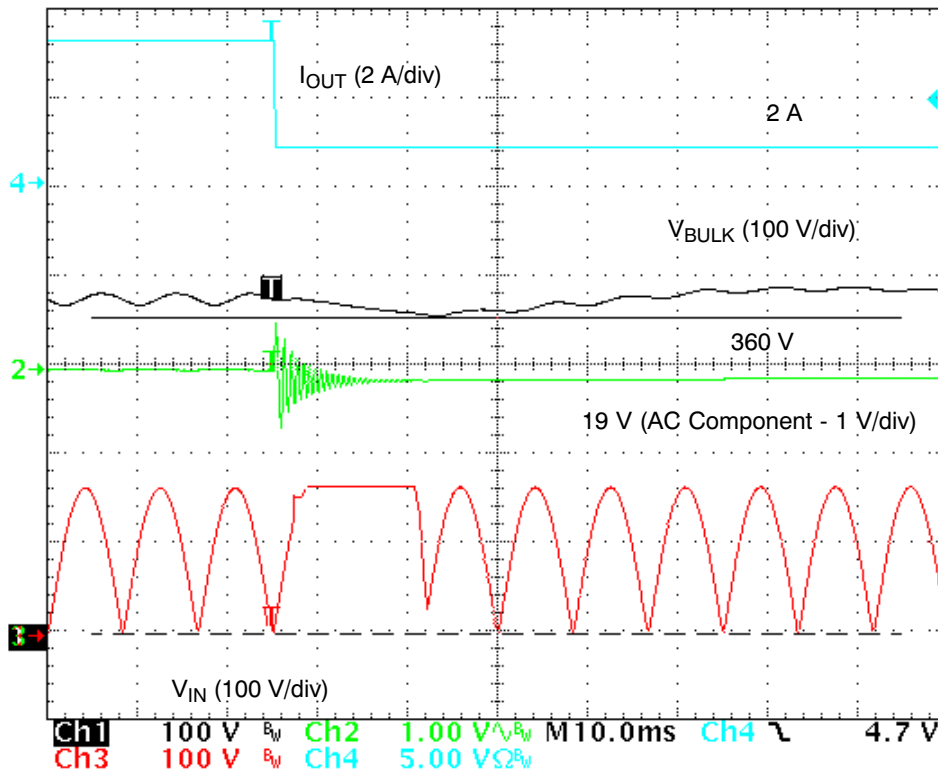

Figure 16. Abrupt Load Decrease at 120 Vrms

Standby Performance

In light load conditions, the circuit enters skip mode to reduce the losses (the PFC stage remaining on in stand-by

to keep on providing the 2-switch forward with its nominal input voltage).

Table 3.

V_{ac}	(V)	90	110
$P_{IN, AVG}$ (No Load)	(mW)	425	450

*These values were obtained by measuring Wh during 2 mn with a power meter YOKOGAWA WT210 at $I_{OUT} = 0$.

One can note that among the measured losses, about 80 mW are due to the two V_{BULK} sensing networks (one for feedback, another one for OVP). We could then improve these results if only one sensing network was used and/or if the leakage current of these sensing networks was lowered by using higher impedance resistors dividers.

The PFC stage enters skip mode when the load current drops below 0.5 A.

The following figures show the V_{BULK} voltage in standby mode at low and high line. We can see that as explained in the data sheet, the NCP1605 skips operation until V_{BULK} reaches 95.5% of its nominal level and then recovers operation. Practically, V_{BULK} oscillates between about 380 and 360 V.

AND8292

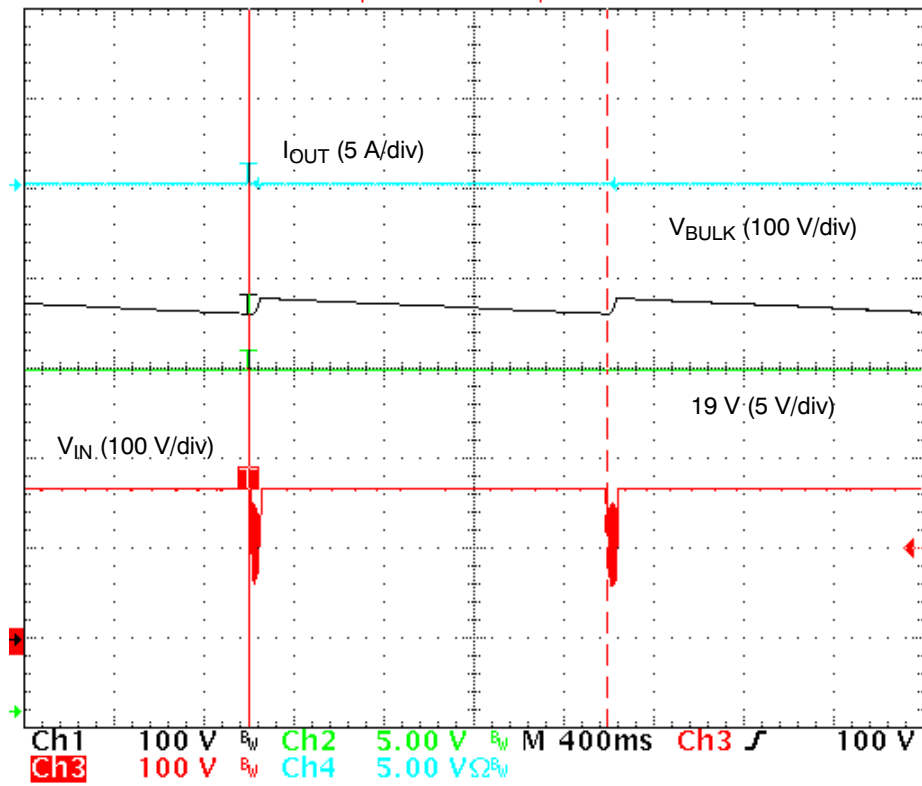

Figure 17. Skip Mode Operation of the PFC Stage at 120 Vrms, No Load.
The Skip Mode Period is About 1.5 s.

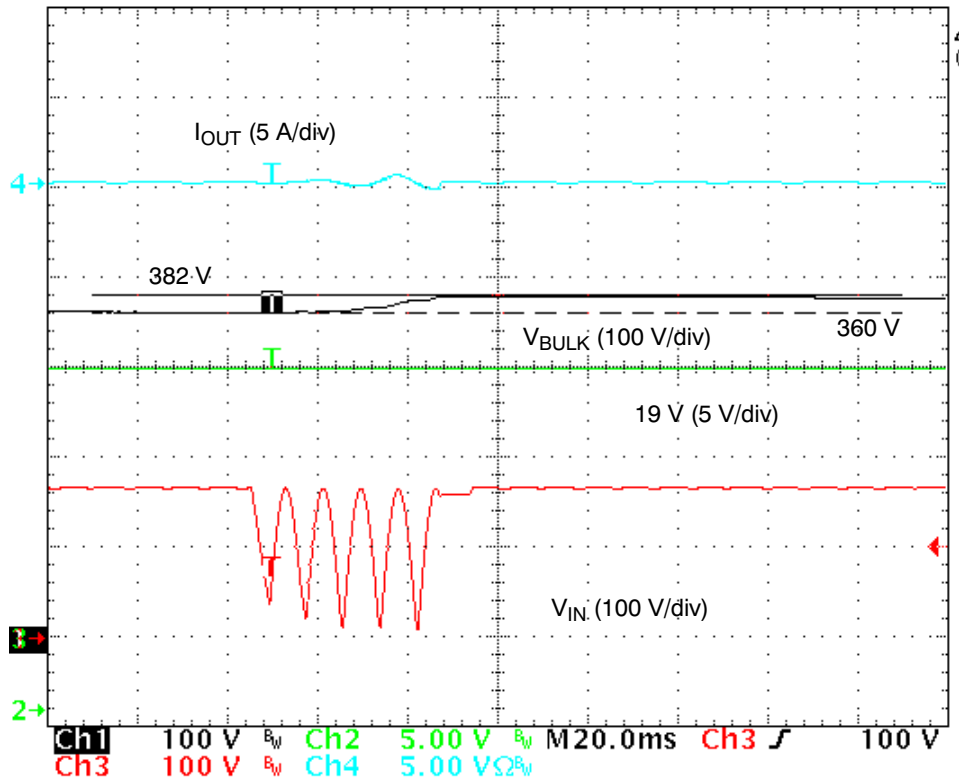

Figure 18. Zoom of the Precedent Plot

AND8292

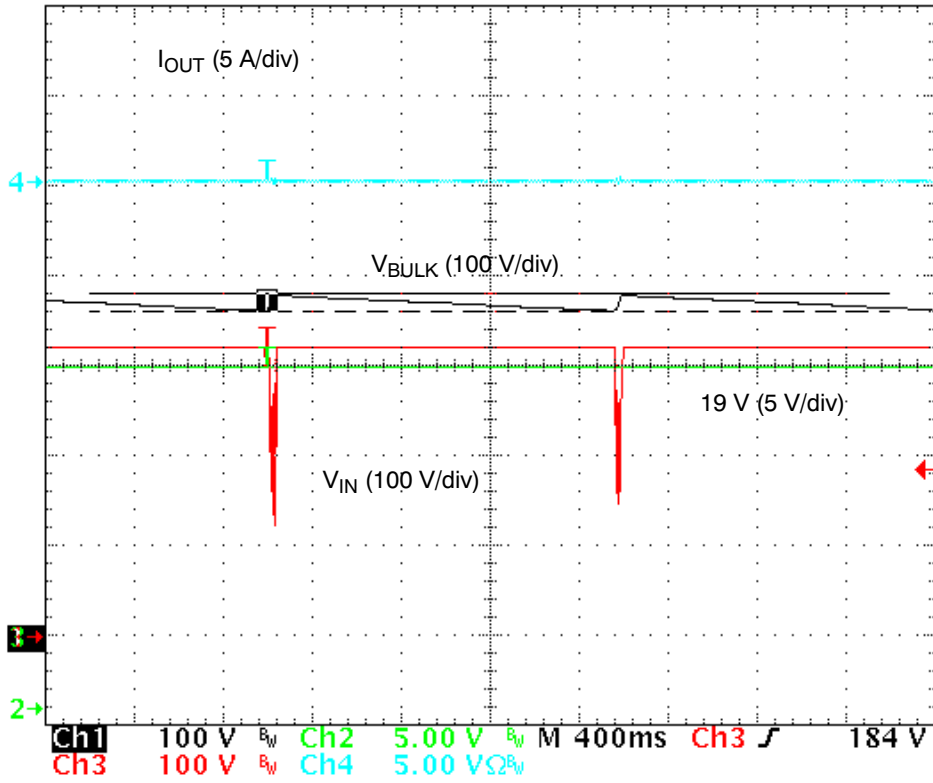

Figure 19. Skip Mode Operation of the PFC Stage at 230 Vrms, No Load

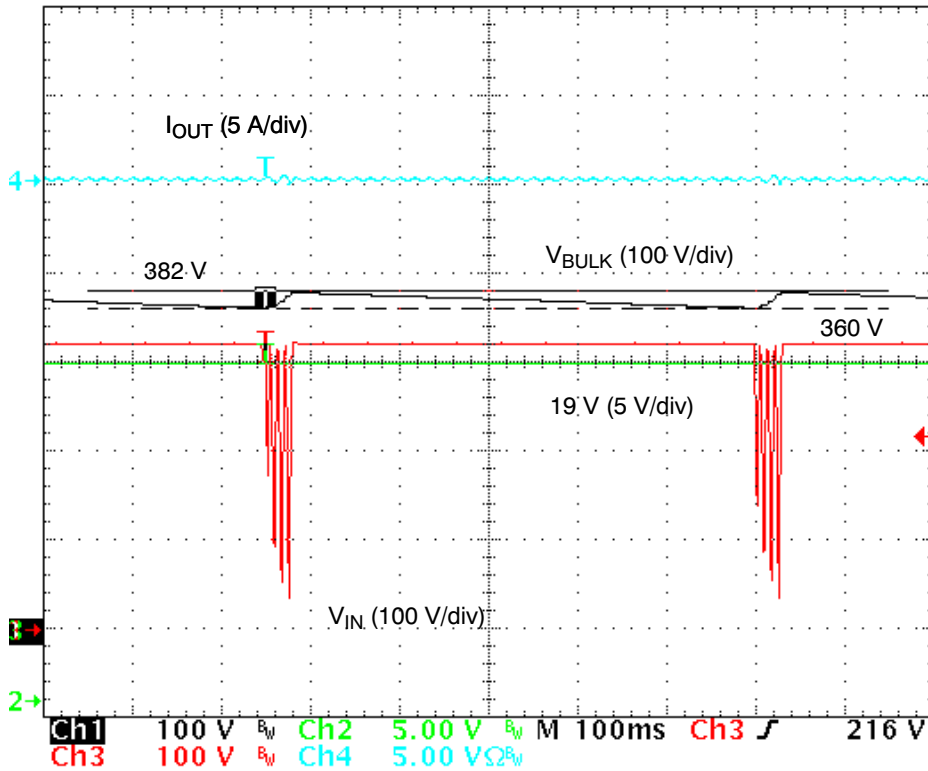

Figure 20. Zoom of the Precedent Plot

AND8292

Thermal Measurements

The following results were obtained using a thermal camera, after a 2.5 h operation at 25°C ambient temperature. These data are indicative.

Table 4.

PFC Stage

Power MOSFET	Bulk Capacitor	Current Sense Resistor	Coil	Input Bridge
85°C	65°C	85°C	75°C	110°C

2-Switch Forward Stage

Power MOSFETs	Transformer	Output Capacitor	Output Coil	Output Diodes (MBR20100)
90°C (Low-Side) 85°C (High-Side)	75°C	55°C	100°C	110°C

*Measurement Conditions: Low line (90 Vrms), full load ($I_{OUT} = 8\text{ A}$).

BILL OF MATERIALS

CM1	CM CHOKE	B82734-R2322-B30	EPCOS
CM2	DM CHOKE	WI-FI series - 150 μH	Würth Elektronik
C1, C11, C15	330 nF X2 Capacitor	PHE840MY6330M	RIFA
C2	Bulk Cap. 100 μF / 450 V	222,215,937,101	BC Components
C3	CMS Cap	4.7 nF	various
C4	CMS Cap	390 pF	various
C8, C17	CMS Cap	220 nF	various
C6, C31	Electrolytic Capacitor	220 μF / 25 V	various
C14, C33, C34, C35, C30, C37	CMS Cap	1 nF	various
C27	Through Hole	470 pF / 100 V	various
C21, C25, C12, C13	2.2 nF Y2 Capacitor	DE2E3KH222MA3B	muRata
C18, C29	Electrolytic Capacitor	UPM1E471MPD	Nichicon
C19, C20, C26	CMS Cap	1 μF	various
C22	CMS Cap	680 nF	various
C5, C23	CMS Cap	10 nF	various
C28	Electrolytic Capacitor	100 μF / 50 V	various
C32	Through Hole	100 nF	various
C39	CMS Cap	100 nF	various
D1	PFC Diode	MUR460RLG	ON Semiconductor
D2, D8, D17	DO-35 Diode	1N4148	various
D14	Schottky Diode	1N5817	ON Semiconductor
D3, D9	16 V Zener Diode	1N5930	ON Semiconductor
D18, D20	16 V Zener Diode	1SMA5930BT3G	ON Semiconductor
D16	3V0 Zener Diode	BZX79-C3V0	ON Semiconductor
D6, D7	Dual Schottky Diode	MBR20100CT	ON Semiconductor
D12, D13	Demagnetization Diodes	MUR160RLG	ON Semiconductor
D15	Rectifier	1N4934RLG	ON Semiconductor
HS1_M1, HS3_D6	Heatsink	KL195/25.4SW	Schaffner
HS1_X31, HS2_X24	Heatsink	KL194/25.4SW	Schaffner
L1	DMT2-26-1 1L	26 μH power choke	CoilCraft
M1	PFC MOSFET	SPP20N60S5	Infineon
Q1, Q2	PNP TO92 Transistor	BC369	ON Semiconductor

D19, D21, D11, R45, R56 are replaced by straps (short circuit)

AND8292

BILL OF MATERIALS

Q1x	SOT23 NPN Transistor	BC846B	ON Semiconductor
Q5, Q6, Q7	NPN TO92 Transistor	BC368	ON Semiconductor
R1, R3, R4, R9, R14, R16, R20, R22	1%, 1/4 W Resistors	1.8 M Ω	various
R2	1%, 1/4 W Resistors	150 Ω	various
R12, R39	1%, 1/4 W Resistors	47 Ω	various
R6	1%, 1/4 W Resistors	2.4 k Ω	various
R7	3 W PFC CS Resistor	RLP3 0R1 1%	Vishay
R8	1%, 1/4 W Resistors	4.7 k Ω	various
R10, R31, R37, R38, R51	1%, 1/4 W Resistors	10 k Ω	various
R13, R44	1%, 1/4 W Resistors	2.2 Ω	various
R15	1%, 1/4 W Resistors	62 k Ω	various
R17, R21	1%, 1/4 W Resistors	27 k Ω	various
R49	1%, 1/4 W Resistors	6.8 k Ω	various
R18, R27, R46, R58	1%, 1/4 W Resistors	22 k Ω	various
R23	1%, 1/4 W Resistors	820 k Ω	various
R24	1%, 1/4 W Resistors	560 k Ω	various
R25	3 W 0.27 Ω Forward CS Resistor	W31-R27 JI	WELWYN
R40, R50, R36	1%, 1/4 W Resistors	10 Ω	various
R28	1%, 1/4 W Resistors	47 k Ω	various
R29, R30	1%, 1/4 W Resistors	3.3 k Ω	various
R35	100 Ω / 4 W Resistor	SBCHE4	Meggitt CGS
R11, R43, R55, R57	1%, 1/4 W Resistors	1 k Ω	various
R42	1%, 1/4 W Resistors	100 Ω	various
R52	1%, 1/4 W Resistors	6.8 k Ω	various
R1x	1%, 1/4 W Resistors	43 k Ω	various
T1	PFC Coil	SICO 977	Sicoenergie
T2	Forward Transformer	SICO 978	Sicoenergie
U1	Diodes Bridge	KBU6K	General Semiconductor
U2	Forward Controller	NCP1217AD133R2G	ON Semiconductor
U3	PFC Controller	NCP1605	ON Semiconductor
X25	01:01 Pulse Transformer	Q3903-A	CoilCraft
X29	Opto-Coupler	SFH6156-2	Infineon
X30	TO92 Voltage Reference	TL431CLPG	ON Semiconductor
X24, X31	Forward MOSFET	SPP11N60S5	Infineon
F1	4 A Fuse	various	various

D19, D21, D11, R45, R56 are replaced by straps (short circuit)

ON Semiconductor and  are registered trademarks of Semiconductor Components Industries, LLC (SCILLC). SCILLC reserves the right to make changes without further notice to any products herein. SCILLC makes no warranty, representation or guarantee regarding the suitability of its products for any particular purpose, nor does SCILLC assume any liability arising out of the application or use of any product or circuit, and specifically disclaims any and all liability, including without limitation special, consequential or incidental damages. "Typical" parameters which may be provided in SCILLC data sheets and/or specifications can and do vary in different applications and actual performance may vary over time. All operating parameters, including "Typicals" must be validated for each customer application by customer's technical experts. SCILLC does not convey any license under its patent rights nor the rights of others. SCILLC products are not designed, intended, or authorized for use as components in systems intended for surgical implant into the body, or other applications intended to support or sustain life, or for any other application in which the failure of the SCILLC product could create a situation where personal injury or death may occur. Should Buyer purchase or use SCILLC products for any such unintended or unauthorized application, Buyer shall indemnify and hold SCILLC and its officers, employees, subsidiaries, affiliates, and distributors harmless against all claims, costs, damages, and expenses, and reasonable attorney fees arising out of, directly or indirectly, any claim of personal injury or death associated with such unintended or unauthorized use, even if such claim alleges that SCILLC was negligent regarding the design or manufacture of the part. SCILLC is an Equal Opportunity/Affirmative Action Employer. This literature is subject to all applicable copyright laws and is not for resale in any manner.

PUBLICATION ORDERING INFORMATION

LITERATURE FULFILLMENT:

Literature Distribution Center for ON Semiconductor
P.O. Box 5163, Denver, Colorado 80217 USA
Phone: 303-675-2175 or 800-344-3860 Toll Free USA/Canada
Fax: 303-675-2176 or 800-344-3867 Toll Free USA/Canada
Email: orderlit@onsemi.com

N. American Technical Support: 800-282-9855 Toll Free
USA/Canada
Europe, Middle East and Africa Technical Support:
Phone: 421 33 790 2910
Japan Customer Focus Center
Phone: 81-3-5773-3850

ON Semiconductor Website: www.onsemi.com

Order Literature: <http://www.onsemi.com/orderlit>

For additional information, please contact your local Sales Representative

AND8292/D