

High Intensity LED Drivers Using NCP3065/NCV3065

Prepared by: Petr Konvicny
ON Semiconductor



ON Semiconductor®

<http://onsemi.com>

Introduction

High brightness LEDs are a prominent source of light and have better efficiency and reliability than conventional light sources. Improvements in high brightness LEDs present the potential for creative new lighting solutions that offer an improved lighting experience while reducing energy demand. LEDs require constant current driver solutions due to their wide forward voltage variation and steep V/I transfer function. For applications that are powered from low voltage AC sources typically used in landscape lighting or low voltage DC sources that may be used in automotive applications, high efficiency driver that can operate over wide range of input voltages to drive series strings of one to several LEDs.

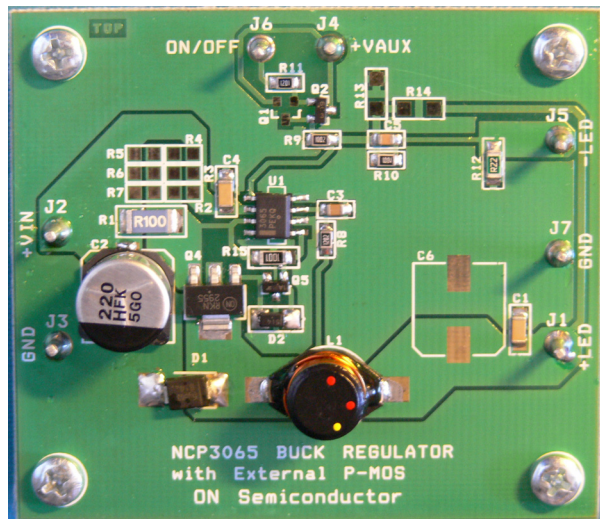

Figure 1. Buck Demo Board

NCP/NCV3065 Demo Board

This application note describes a DC-DC converter circuits that can easily be configured to drive LEDs at several different output currents and can be configured for either AC or DC input. The NCP3065/NCV3065 can be configured in a several driver topologies to a drive string of LEDs: be it traditional low power LEDs or high brightness high power LEDs such as the Lumileds Luxeon™ K2 and Rebel series, the CREE XLAMP™ 4550 or XR series, the

OSRAM OSTAR™, TopLED™ and Golden Dragon™. Configurations like this are found in 12 V_{DC} track lighting applications, automotive applications, and low voltage AC landscaping applications as well as track lighting such as under-cabinet lights and desk lamps that might be powered from standard off-the-shelf 5 V_{DC} and 12 V_{DC} wall adapters. The NCP3065/NCV3065 can operate as a switcher or as a controller. These options are shown below.

The brightness of the LEDs or light intensity is measured in Lumens and is proportional to the forward current flowing through the LED. The light efficiency can vary with the current flowing through the LED string.

The NCP3065 is rated for commercial/industrial temperature ranges and the NCV3065 is automotive qualified.

Demo Board Design Versions

The demo boards are designed to display the full functionality and flexibility of NCP3065 as a driver to drive various LEDs at the low voltage AC and DC sources. The components are selected for the 15 W LED driver application. Based on this circuit, there are many possible configurations with different input voltages and output power levels that could be derived by making some minor components changes. Table 1 shows these different circuit solutions. Each application is described by the schematic and the bill of material and it has the option of LED dimming by using an external PWM signal.

Component Selection

Inductor

When selecting an inductor there is a trade off between inductor size and peak current. In normal applications the ripple current can range from 15% to 100%. The trade off being that with small ripple current the inductance value increases. The advantage is that you can maximize the current out of the switching regulator.

With Output Capacitor Operation

A traditional buck topology includes an inductor followed by an output capacitor which filters the ripple. The capacitor is placed in parallel with the LED or array of LEDs to lower LED ripple current. With this approach the output inductance can be reduced which makes the inductance

smaller and less expensive. Alternatively, the circuit could be run at lower frequency with the same inductor value which improves the efficiency and expands the output voltage range. Equation 2 is used to calculate the capacitor size based on the amount of LED ripple.

No Output Capacitor Operation

A constant current buck regulator such as the NCP3065 focuses on the control of the current through the load, not the voltage across it. The switching frequency of the NCP3065 is in the range of 100 kHz – 300 kHz which is much higher than the human eye can detect. This allows us to relax the ripple current specification to allow higher peak to peak values. This is achieved by configuring the NCP3065 in a continuous conduction buck configuration with low peak to peak ripple thus eliminating the need for an output filter capacitor. The important design parameter is to keep the peak current below the maximum current rating of the LED. Using 15% peak-to-peak ripple results in a good compromise between achieving max average output current without exceeding the maximum limit. This saves space and reduces part count for applications that require a compact footprint. For the common LED currents such as the 350 mA, 700 mA, 1000 mA we setup inductor ripple current to the ±52.5 mA, ±105 mA, ±150 mA. With respect these requirements we are able to select inductor value (Equation 1).

$$L = \frac{V_{IN} - V_{OUT}}{\Delta I_{MAX}} \times T_{ON} \tag{eq. 1}$$

Output Capacitor

When you choose output capacitor we have to think about its value, ESR and ripple current.

$$C_{OUT} = \frac{\Delta I}{\Delta V * 8 * f} = \frac{V_{IN} * (1 - D) * D}{8 * L * f^2 * \Delta V_{OUT}} \tag{eq. 2}$$

Current Feedback Loop

To drive LEDs in a constant current mode, the feedback for the regulator is taken by sensing the voltage drop across the sensing resistor R₁₂, see Figures 2 or 8. The RC circuit (R10 & C5) between the sense resistor and the feedback pin improves converter transient response. The low feedback reference voltage of 235 mV allows the use of low power and lower cost sense resistor. Equation 3 calculates the sense resistor value.

$$I_{OUT} = \frac{V_{REF}}{R_{sense}} = \frac{0.235 \text{ V}}{R_{sense}} \text{ [A]} \tag{eq. 3}$$

LED current (mA)	Sensing resistor value (mΩ)	
350	680	1/4W
700	330	1/4W
1000	220	1/4W

Table 1. COMPONENTS CHANGES FOR DIFFERENT CONFIGURATIONS

LED Driver	Application	V _{IN}	I _{LED}	V _F	L	C _{OUT}	R ₈
		(V)	(mA)	(V)	(μH)	(μF)	(Ω)
BUCK	12 V _{DC} 1 W LED	10 – 14	350	3.6	47	100	12k
					150	0	3k3
	12 V _{DC} 3 W LED	10 – 14	700 or 350	3.6 or 7.2	47	100	16k
					150	0	12k
	12 V _{DC} 5 W LED	10 – 14	700 or 1000	7.2 or 3.6	47	100	12k
					150	0	12k
	24 V _{DC} 5 W LED	21 – 27	350	14	68	100	160k
					220	0	39k
	24 V _{DC} 10 W LED	21 – 27	700	14	68	100	150k
					220	0	100k
	12 V _{AC} 1 W LED	14 – 20	350	3.6	47	100	7k5
					220	0	7k5
	12 V _{AC} 3 W LED	14 – 20	700 or 350	3.6 or 7.2	47	100	22k
					220	0	22k
12 V _{AC} 5 W LED	14 – 20	700 or 1000	7.2 or 3.6	47	100	36k	
				220	0	100k/16k	
12 V _{AC} 5 W	14 – 20	350	14	47	100	NU	
				220	0	NU	
12 V _{AC} 15 W	21 – 27	1000	14	47	100	82k	

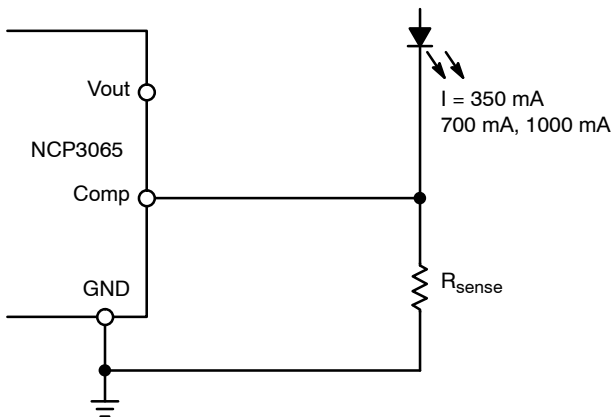

Figure 2. NCP3065 Current Feedback

Dimming Possibility

The emitted LED light is proportional to average output (LED) current. The NCP3065 is capable of analog and digital PWM dimming. For the dimming we have three possibilities how to create it. We basically use a PWM signal with variable duty cycle for the managing output current value. The COMP or IPK pin of the NCP3065 is used to provide dimming capability. In digital input mode the PWM input signal inhibits switching of the regulator and reducing the average current through the LEDs. In analog input mode a PWM input signal is RC filtered and the resulting voltage is summed with the feedback voltage thus reduces the

average current through the LEDs Figure 5. The component value of the RC filter are dependent on the PWM frequency. Due to this, the frequency has to be higher. Figure 17 illustrates the linearity of the digital dimming function with a 200 Hz digital PWM. The dimming frequency range for digital input mode is basically from 200 Hz to 1 kHz. For frequencies below 200 Hz the human eye will see the flicker. The low dimming frequencies are EMI convenient and an impact to it is small.

The Figure 3 shows us an example of solution A, which uses the COMP pin to perform the dimming function and Figure 4 show us an example of solution B. The behavior of the NCP3065 with dimming you can see in Figures 15 and 16 and dimming linearity in the Figure 17. As you can see in these figures there aren't any delays in the rise or fall edges, which give us the required dimming linearity.

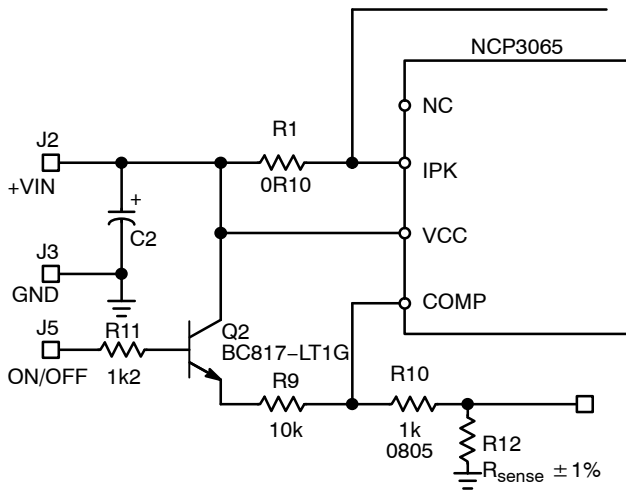

Figure 3. NCP3065 Dimming Solution A

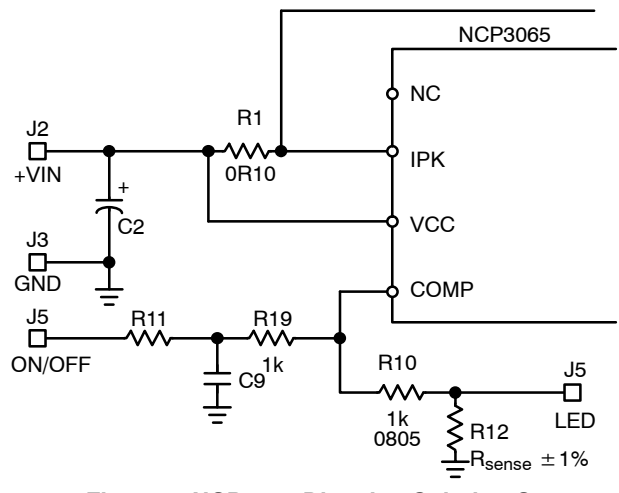

Figure 5. NCP3065 Dimming Solution C

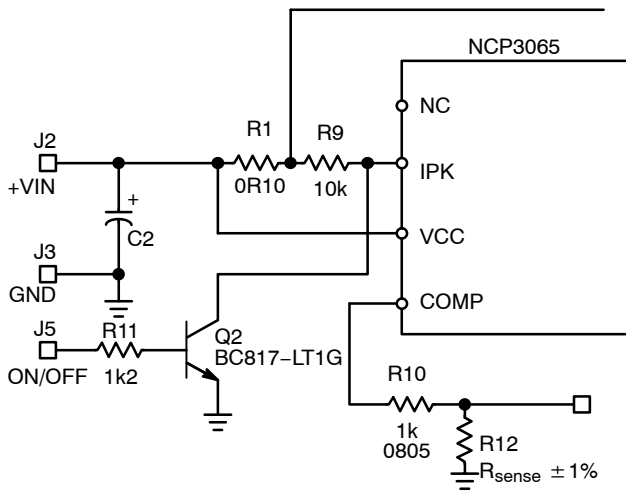

Figure 4. NCP3065 Dimming Solution B

AND8298

BOARD LAYOUT

The layout of the evaluation board and schematic is shown below in Figure 6 and Figure 7.

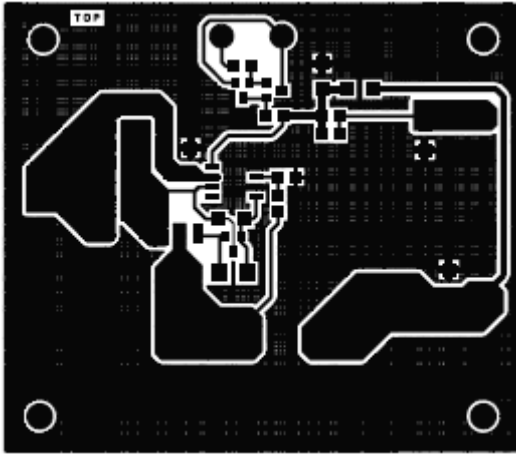

Figure 6. Demo board layout Top (Not in Scale)

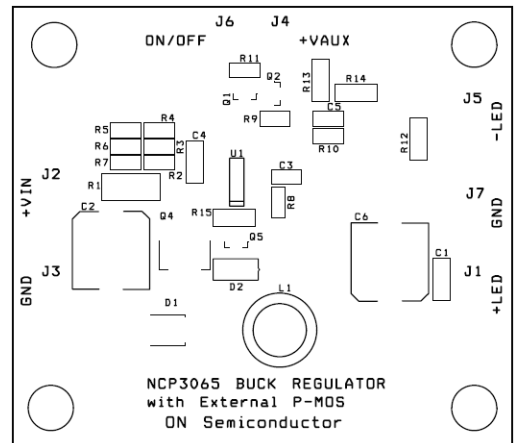

Figure 7. Demo Board Silk Screen Top

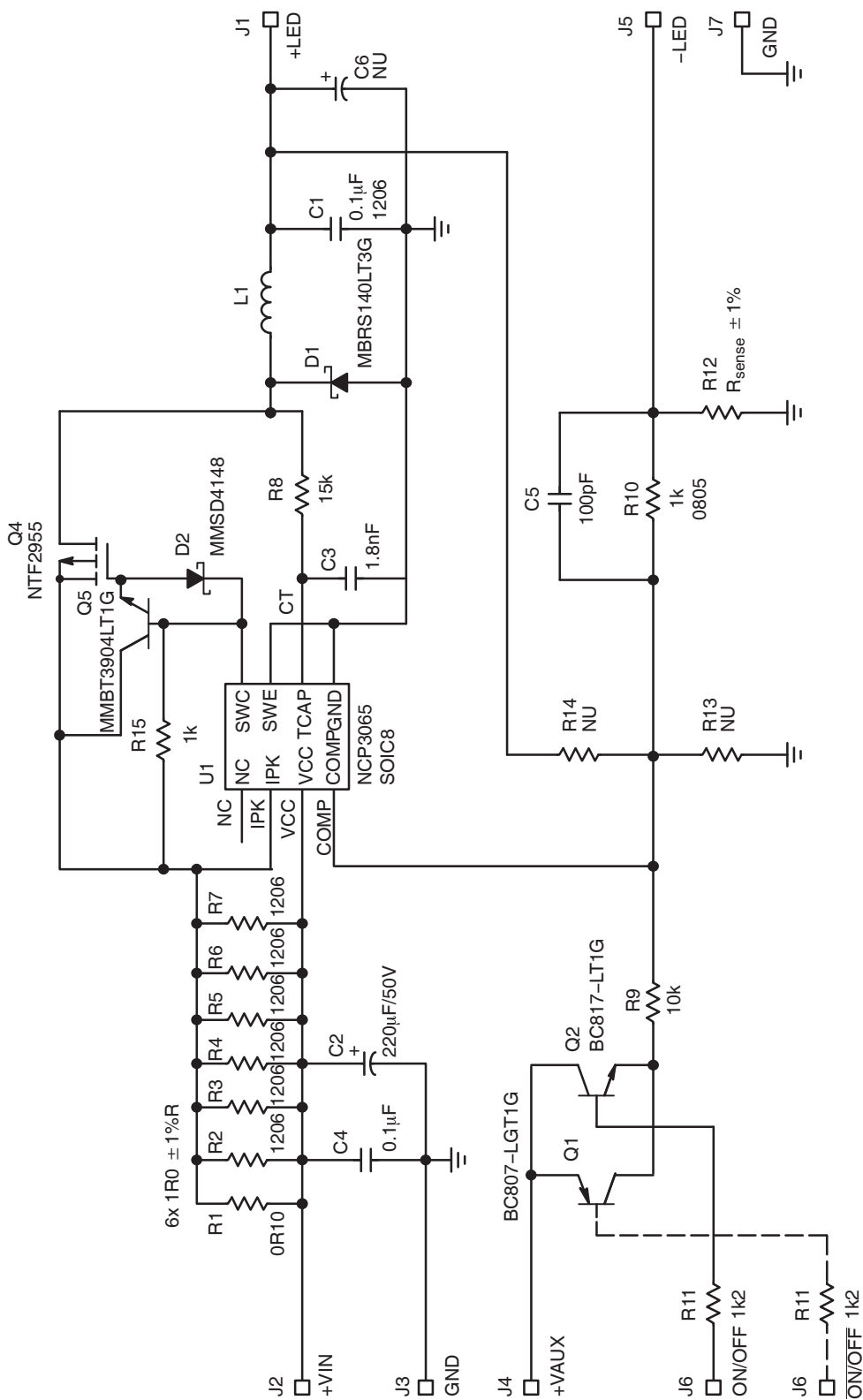

Figure 8. 12 V_{DC} and 24 V_{DC} Input LED Driver Schematic

AND8298

Table 2. 12 V_{DC} INPUT 1 W LED DRIVER WITHOUT OUTPUT CAPACITOR BILL OF MATERIALS

Qty	Reference	Part Description	Mfg P/N	Mfg	Package	Mtg
2	C1, C4	100 nF, Ceramic Capacitor			1206	SMD
1	C2	220 μ F/50 V, Electrolytic Capacitor	EEEVFK1H221P	Panasonic	G, 10x10.2	SMD
1	C3	1.8 nF, Ceramic Capacitor			0805	SMD
1	C5	100 pF, Ceramic Capacitor			0805	SMD
1	D1	1 A, 40 V Schottky Rectifier	MBRS140LT3G	ON Semiconductor	SMB	SMD
1	D2	Switching Diode	MMSD4148T1G	ON Semiconductor	SOD123	SMD
1	L1	Surface Mount Power Inductor	DO3340P-154MLD	Coilcraft		SMD
1	Q4	Power MOSFET, P-Channel	NTF2955T1G	ON Semiconductor	SOT223	SMD
1	Q5	General Purpose Transistor	MMBT3904LT1G	ON Semiconductor	SOT23	SMD
1	R1	100 m Ω , 0.5 W			2010	SMD
1	R8	3k3, Resistor			0805	SMD
1	R9	10 k Ω , Resistor			0805	SMD
2	R10, R15	1 k Ω , Resistor			0805	SMD
1	R11	1.2 k Ω , Resistor			0805	SMD
1	R12	680 m Ω , \pm 1%			1206	SMD
1	U1	DC-DC Controller	NCP3065	ON Semiconductor	SOIC8	SMD

Table 3. 12 V_{DC} INPUT 1 W LED DRIVER WITH OUTPUT CAPACITOR BILL OF MATERIALS

Qty	Reference	Part Description	Mfg P/N	Mfg	Package	Mtg
2	C1, C4	100 nF, Ceramic Capacitor			1206	SMD
1	C2	220 μ F/50 V, Electrolytic Capacitor	EEEVFK1H221P	Panasonic	G, 10x10.2	SMD
1	C3	1.8 nF, Ceramic Capacitor			0805	SMD
1	C5	100 pF, Ceramic Capacitor			0805	SMD
1	C6	100 μ F/50 V, Electrolytic Capacitor	EEEVFK1H101P	Panasonic	F, 8x10.2	SMD
1	D1	1 A, 40 V Schottky Rectifier	MBRS140LT3G	ON Semiconductor	SMB	SMD
1	D2	Switching Diode	MMSD4148T1G	ON Semiconductor	SOD123	SMD
1	L1	Surface Mount Power Inductor	DO3316P-473MLD	Coilcraft		SMD
1	Q4	Power MOSFET, P-Channel	NTF2955T1G	ON Semiconductor	SOT223	SMD
1	Q5	General Purpose Transistor	MMBT3904LT1G	ON Semiconductor	SOT23	SMD
1	R1	100 m Ω , 0.5 W			2010	SMD
1	R8	12k, Resistor			0805	SMD
1	R9	10 k Ω , Resistor			0805	SMD
2	R10, R15	1 k Ω , Resistor			0805	SMD
1	R11	1.2 k Ω Resistor			0805	SMD
1	R12	680 m Ω , \pm 1%			1206	SMD
1	U1	DC-DC Controller	NCP3065	ON Semiconductor	SOIC8	SMD

Table 4. 12 V_{DC} Input 1 W LED Drivers Test Results

Test	Result
Efficiency With Output Cap Without Output Cap	74% 72%
Line regulation	\pm 3%
Output Current Ripple With Output Cap Without Output Cap	< 50 mA < 100 mA

AND8298

Table 5. 12 V_{DC} INPUT 3 W LED DRIVER WITHOUT OUTPUT CAPACITOR BILL OF MATERIALS

Qty	Reference	Part Description	Mfg P/N	Mfg	Package	Mtg
2	C1, C4	100 nF, Ceramic Capacitor			1206	SMD
1	C2	220 μ F/50 V, Electrolytic Capacitor	EEEVFK1H221P	Panasonic	G, 10x10.2	SMD
1	C3	1.8 nF, Ceramic Capacitor			0805	SMD
1	C5	100 pF, Ceramic Capacitor			0805	SMD
1	D1	2 A, 40 V Schottky Rectifier	MBRS240LT3G	ON Semiconductor	SMB	SMD
1	D2	Switching Diode	MMSD4148T1G	ON Semiconductor	SOD123	SMD
1	L1	Surface Mount Power Inductor	DO3340P-154MLD	Coilcraft		SMD
1	Q4	Power MOSFET, P-Channel	NTF2955T1G	ON Semiconductor	SOT223	SMD
1	Q5	General Purpose Transistor	MMBT3904LT1G	ON Semiconductor	SOT23	SMD
1	R1	100 m Ω , 0.5 W			2010	SMD
1	R8	12k, Resistor			0805	SMD
1	R9	10 k Ω , Resistor			0805	SMD
2	R10, R15	1 k Ω , Resistor			0805	SMD
1	R11	1.2 k Ω , Resistor			0805	SMD
1	R12	330 m Ω , \pm 1%			1206	SMD
1	U1	DC-DC Controller	NCP3065	ON Semiconductor	SOIC8	SMD

Table 6. 12 V_{DC} INPUT 3 W LED DRIVER WITH OUTPUT CAPACITOR BILL OF MATERIALS

Qty	Reference	Part Description	Mfg P/N	Mfg	Package	Mtg
2	C1, C4	100 nF, Ceramic Capacitor			1206	SMD
1	C2	220 μ F/50 V, Electrolytic Capacitor	EEEVFK1H221P	Panasonic	G, 10x10.2	SMD
1	C3	1.8 nF, Ceramic Capacitor,			0805	SMD
1	C5	100 pF, Ceramic Capacitor,			0805	SMD
1	C6	100 μ F/50 V, Electrolytic Capacitor	EEEVFK1H101P	Panasonic	F, 8x10.2	SMD
1	D1	2 A, 40 V Schottky Rectifier	MBRS240LT3G	ON Semiconductor	SMB	SMD
1	D2	Switching Diode	MMSD4148T1G	ON Semiconductor	SOD123	SMD
1	L1	Surface Mount Power Inductor	DO3316P-473MLD	Coilcraft		SMD
1	Q4	Power MOSFET, P-Channel	NTF2955T1G	ON Semiconductor	SOT223	SMD
1	Q5	General Purpose Transistor	MMBT3904LT1G	ON Semiconductor	SOT23	SMD
1	R1	100 m Ω , 0.5 W			2010	SMD
1	R8	16k, Resistor			0805	SMD
1	R9	10 k Ω , Resistor			0805	SMD
2	R10, R15	1 k Ω , Resistor			0805	SMD
1	R11	1.2 k Ω , Resistor			0805	SMD
1	R12	330 m Ω , \pm 1%			1206	SMD
1	U1	DC-DC Controller	NCP3065	ON Semiconductor	SOIC8	SMD

Table 7. 12 V_{DC} Input 3 W LED Drivers Test Results

Test	Result
Efficiency	
With Output Cap	76%
Without Output Cap	76%
Line regulation	\pm 5%
Output Current Ripple	
With Output Cap	< 50 mA
Without Output Cap	< 90 mA

AND8298

Table 8. 12 V_{DC} INPUT 5 W LED DRIVER WITHOUT OUTPUT CAPACITOR BILL OF MATERIALS

Qty	Reference	Part Description	Mfg P/N	Mfg	Package	Mtg
2	C1, C4	100 nF, Ceramic Capacitor			1206	SMD
1	C2	220 μ F/50 V, Electrolytic Capacitor	EEEVFK1H221P	Panasonic	G, 10x10.2	SMD
1	C3	1.8 nF, Ceramic Capacitor			0805	SMD
1	C5	100 pF, Ceramic Capacitor			0805	SMD
1	D1	2 A, 40 V Schottky Rectifier	MBRS240LT3G	ON Semiconductor	SMB	SMD
1	D2	Switching Diode	MMSD4148T1G	ON Semiconductor	SOD123	SMD
1	L1	Surface Mount Power Inductor	DO3340P-154MLD	Coilcraft		SMD
1	Q4	Power MOSFET, P-Channel	NTF2955T1G	ON Semiconductor	SOT223	SMD
1	Q5	General Purpose Transistor	MMBT3904LT1G	ON Semiconductor	SOT23	SMD
1	R1	100 m Ω , 0.5 W			2010	SMD
1	R8	12k, Resistor			0805	SMD
1	R9	10 k Ω , Resistor			0805	SMD
2	R10, R15	1 k Ω , Resistor			0805	SMD
1	R11	1.2 k Ω , Resistor			0805	SMD
1	R12	220 m Ω , \pm 1%			1206	SMD
1	U1	DC-DC Controller	NCP3065	ON Semiconductor	SOIC8	SMD

Table 9. 12 V_{DC} INPUT 5 W LED DRIVER WITH OUTPUT CAPACITOR BILL OF MATERIALS

Qty	Reference	Part Description	Mfg P/N	Mfg	Package	Mtg
2	C1, C4	100 nF, Ceramic Capacitor			1206	SMD
1	C2	220 μ F/50 V, Electrolytic Capacitor	EEEVFK1H221P	Panasonic	G, 10x10.2	SMD
1	C3	1.8n F, Ceramic Capacitor,			0805	SMD
1	C5	100 pF, Ceramic Capacitor,			0805	SMD
1	C6	100 μ F/50 V, Electrolytic Capacitor	EEEVFK1H101P	Panasonic	F, 8x10.2	SMD
1	D1	2 A, 40 V Schottky Rectifier	MBRS240LT3G	ON Semiconductor	SMB	SMD
1	D2	Switching Diode	MMSD4148T1G	ON Semiconductor	SOD123	SMD
1	L1	Surface Mount Power Inductor	DO3316P-473MLD	Coilcraft		SMD
1	Q4	Power MOSFET, P Channel	NTF2955T1G	ON Semiconductor	SOT223	SMD
1	Q5	General Purpose Transistor	MMBT3904LT1G	ON Semiconductor	SOT23	SMD
1	R1	100 m Ω , 0.5 W			2010	SMD
1	R8	15k, resistor			0805	SMD
1	R9	10 k Ω , resistor			0805	SMD
2	R10, R15	1 k Ω , resistor			0805	SMD
1	R11	1.2 k Ω , resistor			0805	SMD
1	R12	220 m Ω , \pm 1%			1206	SMD
1	U1	DC-DC controller	NCP3065	ON Semiconductor	SOIC8	SMD

Table 10. 12 V_{DC} Input 5 W LED Drivers Test Results

Test	Result
Efficiency	75%
Line regulation	\pm 4%
Output Current Ripple With Output Cap Without Output Cap	< 50mA < 110mA

AND8298

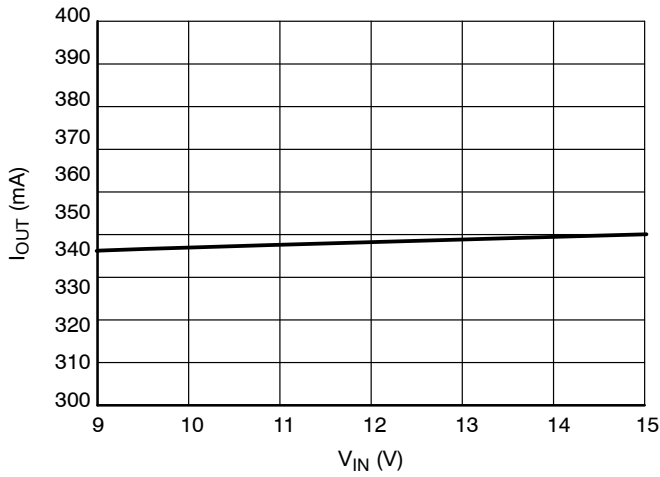

Figure 10. Current Regulation, 12 V_{DC} Input
1 W LED Driver

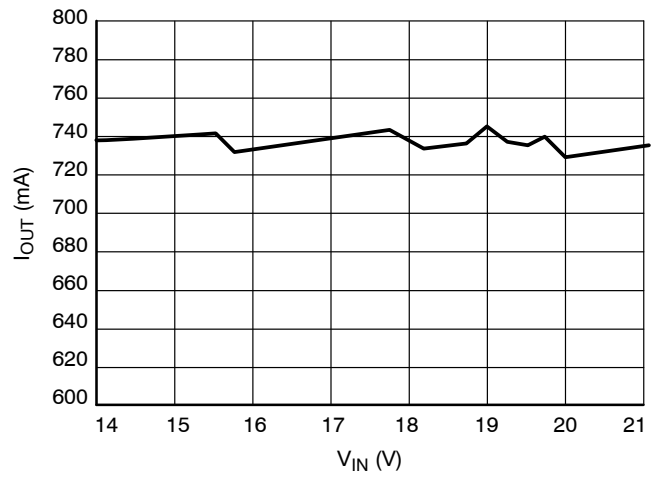

Figure 11. Current Regulation, 12 V_{AC} Input
3 W LED Driver

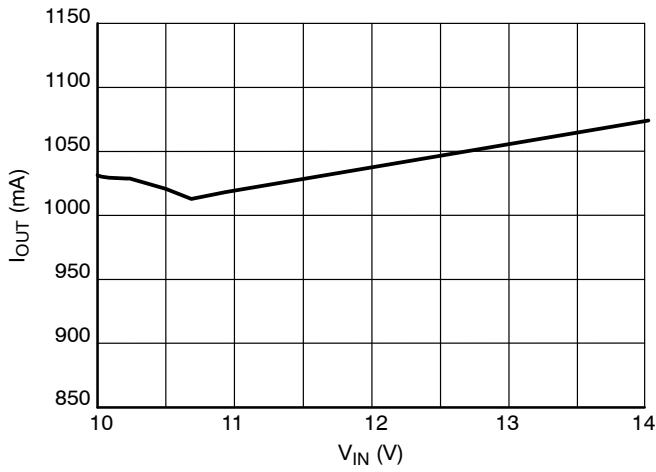

Figure 12. Current Regulation, 12 V_{DC} Input
5 W LED Driver

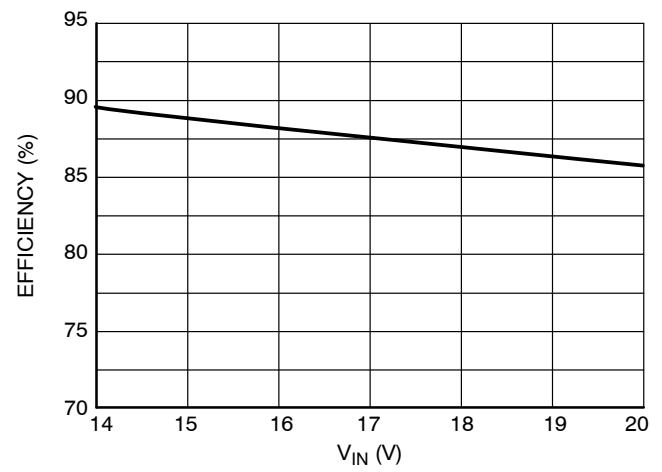

Figure 13. 12 V_{AC} Input 5 W LED Driver
Efficiency

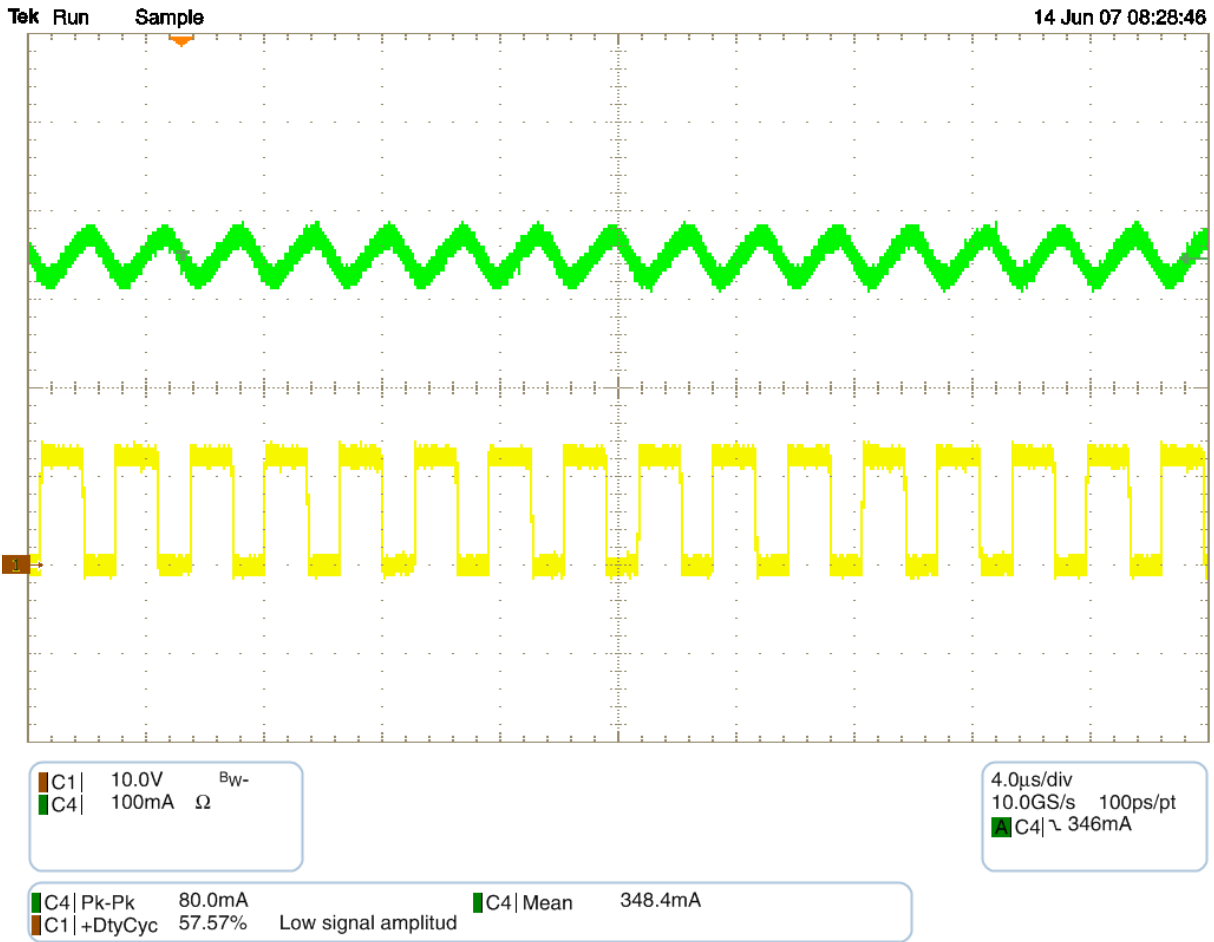

Figure 14. 12 V_{DC}, I_{OUT} = 350 mA Input Inductor Ripple Without Output Capacitor, C1 Inductor Input, C4 Inductor Current

Table 11. BUCK EFFICIENCY RESULTS FOR DIFFERENT RIPPLE WITH NO OUTPUT CAPACITOR

Efficiency	1 LED, V _f = 3.6 V	2 LEDs, V _f = 3.6 V	4 LED, V _f = 14.4 V
V_{IN} = 12 V_{DC}			
I _{OUT} = 350 mA	> 74%	> 83%	–
I _{OUT} = 700 mA	> 76%	> 83%	–
I _{OUT} = 1000 mA	> 75%	–	–
V_{IN} = 12 V_{AC}			
I _{OUT} = 350 mA	> 70%	> 80%	> 87%
I _{OUT} = 700 mA	> 72%	> 82%	–
I _{OUT} = 1000 mA	> 70%	–	–
V_{IN} = 24 V_{DC}			
I _{OUT} = 350 mA	–	–	> 82%
I _{OUT} = 700 mA	–	–	> 86%
I _{OUT} = 1000 mA	–	–	> 87%

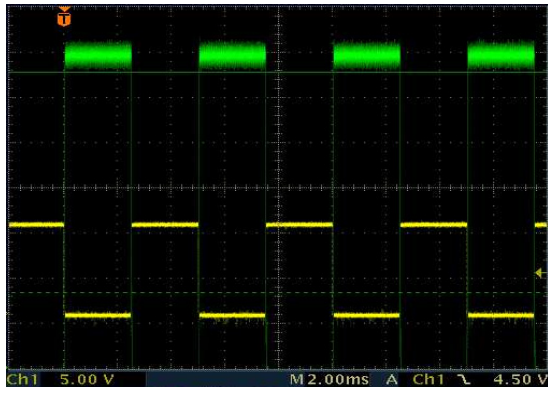

Figure 15. NCP3065 Behavior with Dimming, Frequency is 200 Hz, Duty Cycle 50%

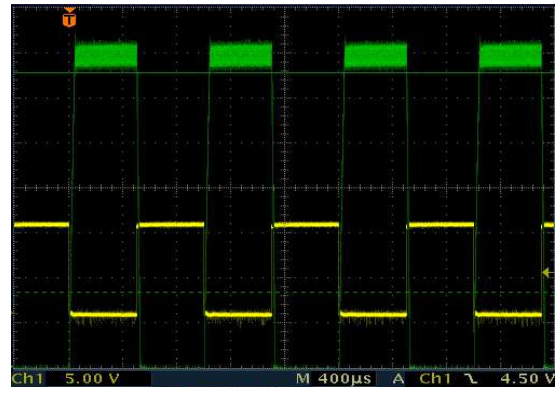

Figure 16. NCP3065 Dimming Behavior, Frequency 1 kHz, Duty Cycle 50%

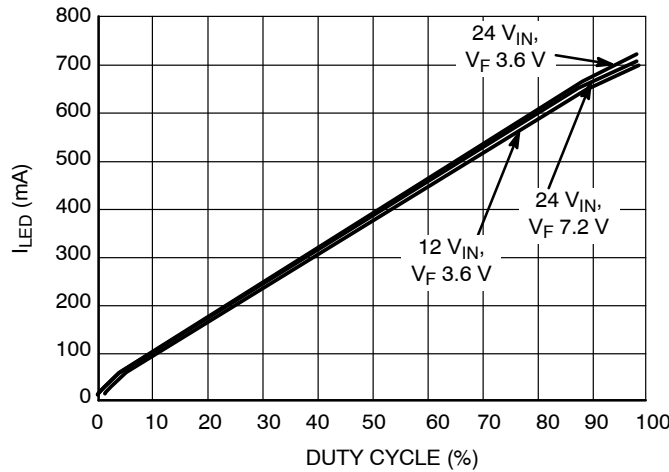

Figure 17. Output Current Dependency on the Dimming Duty Cycle

Pulse feedback design

The NCP3065 is a burst-mode architecture product which is similar but not exactly the same as a hysteretic architecture. The output switching frequency is dependent on the input and output conditions. The NCP3065 oscillator generates a constant frequency that is set by an external capacitor. This output signal is then gated by the peak current comparator and the oscillator. When the output current is above the threshold voltage the switch turns off. When the output current is below the threshold voltage the switch is turned on and gated with the oscillator. A simplified schematic is shown in Figure 18. This may cause possible overshoots on the output. Using the pulse feedback

circuit will reduce this overshoot. This will result in a stabilized switching frequency and reduce the overshoot and output ripple. The pulse feedback circuit is implemented by adding an external resistor R8 between the CT pin and inductor input as shown in the buck schematic Figure 8.

The resistor value is dependent on the input/output conditions and switching frequency. The typical range is 3k to 200k. Table 1 contains a list of typical applications and the recommended value for the pulse feedback resistor. Using an adjustable resistor in place of R8 when evaluating an application will allow the designer to optimize the value and make a final selection.

AND8298

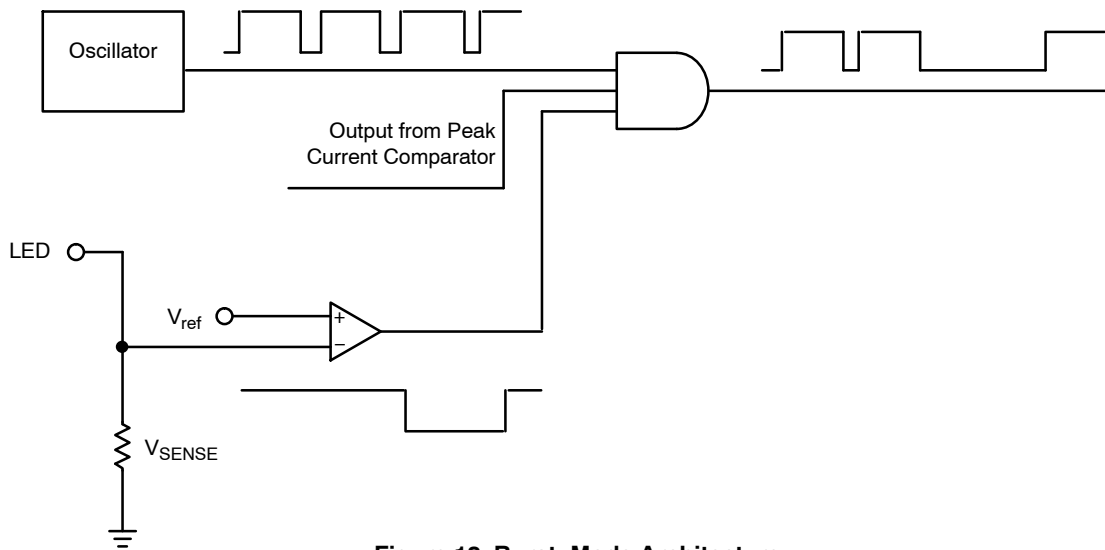

Figure 18. Burst-Mode Architecture

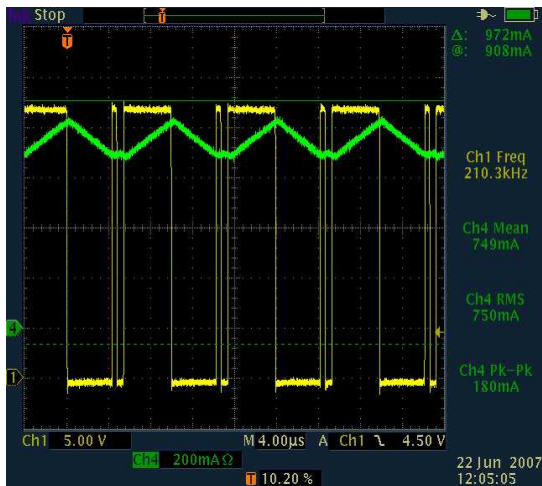

Figure 19. Switching Waveform Without Pulse Feedback

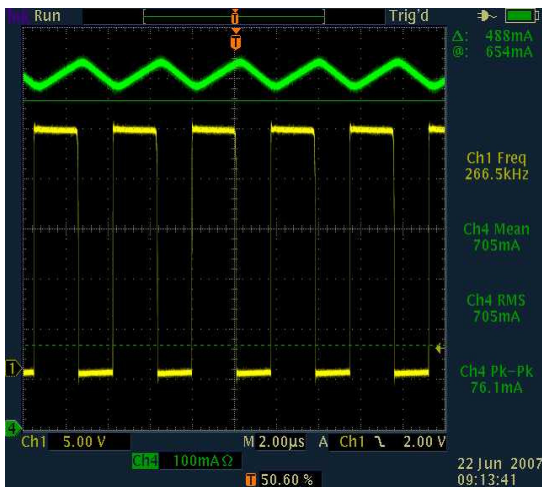

Figure 20. Switching Waveform With Pulse Feedback

Figures 19 and 20 show the effect of the pulse feedback resistor on the switching waveforms and load current ripple. This results in a fixed frequency switching with constant duty cycle, which is only dependent upon the input and output voltage ratio. When the ratio (V_{OUT}/V_{IN}) is near 1 (high duty cycle) over the entire input voltage range, the pulse feedback is not needed.

Boost Converter Demo Board

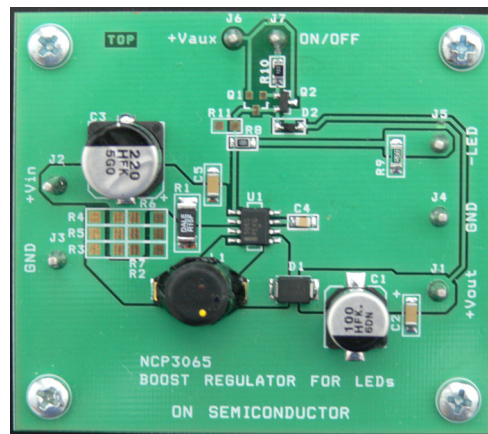

Figure 21. Boost Demo Board

Boost Converter Topology

The Boost converter schematic is illustrated in Figure 22. When the low side power switch is turned on, current drawn from the input begins to flow through the inductor and the current I_{ton} rises up. When the low side switch is turned off, the current I_{toff} circulates through diode D1 to the output capacitor and load. At the same time the inductor voltage is added with the input power supply voltage and as long as this is higher than the output voltage, the current continues to flow through the diode. Provided that the current through the inductor is always positive, the converter is operating in continuous conduction mode (CCM). On the next switching cycle, the process is repeated.

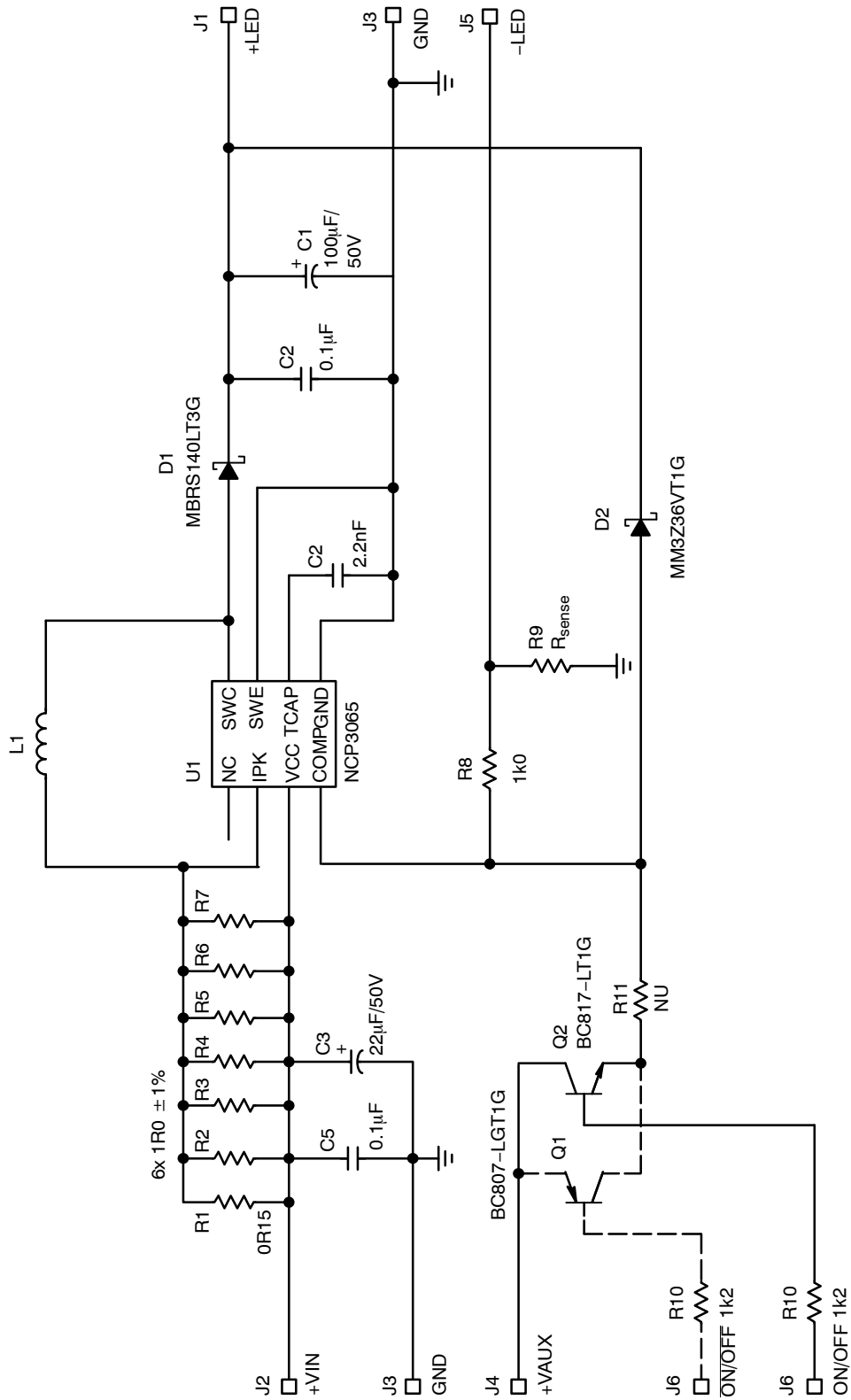

Figure 22. 12 V_{DC} Input LED Driver Schematic

When operating in CCM the output voltage is equal to

$$V_{OUT} = V_{IN} \cdot \frac{1}{1 - D}$$

The duty cycle is defined as

$$D = \frac{t_{ON}}{t_{ON} + t_{OFF}} = \frac{t_{ON}}{T}$$

The input ripple current is defined as

$$\Delta I = V_{IN} \frac{D}{f \cdot L}$$

The load voltage must always be higher than the input voltage. This voltage is defined as

$$V_{load} = V_{sense} + n \cdot V_f$$

where V_f = LED forward voltage, V_{sense} is the converter reference voltage, and n = number of LED's in cluster.

Since the converter needs to regulate current independent of load voltage variation, a sense resistor is placed across the feedback voltage. This drop is calculated as

$$V_{sense} = I_{load} + n \cdot R_{sense}$$

The V_{sense} corresponds to the internal voltage reference or feedback comparator threshold.

Simple Boost 350 mA LED driver

The NCP3065 boost converter is configured as a LED driver is shown in Figure 22. It is well suited to automotive or industrial applications where limited board space and a high voltage and high ambient temperature range might be found. The NCP3065 also incorporates safety features such as peak switch current and thermal shutdown protection. The schematic has an external high side current sense resistor that is used to detect if the peak current is exceeded. In the constant current configuration, protection is also required in the event of an open LED fault since current will continue to charge the output capacitor causing the output voltage to rise. An external zener diode is used to clamp the output voltage in this fault mode. Although the NCP3065 is designed to operate up to 40 V additional input transient protections might be required in certain automotive applications due to inductive load dump.

The main operational frequency is determined by the external capacitor C4. The t_{on} time is controlled by the internal feedback comparator, peak current comparator and main oscillator. The output current is configured by an internal feedback comparator with negative feedback input. The positive input is connected to an internal voltage reference of 0.235 V with 10% precision over temperature. The nominal LED current is setup by a feedback resistor. This current is defined as:

$$I_{OUT} = \frac{0.235}{R_{sense}}$$

There are two approaches to implement LED dimming. Both use the negative comparator input as a shutdown input. When the pin voltage is higher than 0.235 V the switch

transistor is off. You could connect an external PWM signal to pin ON/OFF and a power source to pin + V_{AUX} to realize the PWM dimming function. When the dimming signal exceeds the turn on threshold of the external PNP or NPN transistor, the comp pin will be pulled up. A TTL level input can also be used for dimming control. The range of the dimming frequency is from 100 Hz to 1 kHz, but it is recommended to use frequency around 200 Hz as this is safely above the frequency where the human eye can detect the pulsed behavior, in addition this value is convenient to minimize EMI. There are two options to determine the dimming polarity. The first one uses the NPN switching transistor and the second uses a PNP switching transistor. The switch on/off level is dependent upon the chosen dimming topology. The external voltage source (V_{AUX}) should have a voltage ranging from +5 V_{DC} to + V_{IN} . Figure 17 illustrates average LEDs current dependency on the dimming input signal duty cycle.

For cycle by cycle switch current limiting a second comparator is used which has a nominal 200 mV threshold. The value of resistor R1 determines the current limit value and is configured according to the following equation.

$$I_{pk(SW)} = \frac{0.2}{0.15} = 1.33 \text{ A}$$

The maximum output voltage is clamped with an external zener diode, D2 with a value of 36 V which protects the NCP3065 output from an open LED fault.

The demo board has a few options to configure it to your needs. You can use one 150 m Ω (R1) or a combination of parallel resistors such as six 1 Ω resistors (R2 – R7) for current sense.

To evaluate the functionality of the board, high power LEDs with a typical $V_f = 3.42 \text{ V @ } 350 \text{ mA}$ were connected in several serial combinations (4, 6, 8 LED's string) and 4 chip and 6 chip LEDs with $V_f = 14 \text{ V}$ respectively $V_f = 20.8 \text{ V @ } 700 \text{ mA}$.

Number of LEDs	String Forward Voltage at 25°C		
	Min	Typ	Max
4	11.16	13.68	15.96
6	16.74	20.52	23.94
8	22.32	27.36	31.92

The efficiency was calculated by measuring the input voltage and input current and LED current and LED voltage drop. The output current is dependent on the peak current, inductor value, input voltage and voltage drop value and of course on the switching frequency.

$$I_{OUT} = (D - D^2) \cdot \left(\frac{I_{pk(SW)}}{D} - \frac{V_{IN} - V_{SWCE}}{2 \cdot L \cdot f} \right) [A]$$

$$D = \frac{V_{OUT} + V_F - V_{IN}}{V_{OUT} + V_F - V_{SWCE}} [-]$$

V_{OUT}	Output Voltage
V_{IN}	Input Voltage
V_F	Schottky Diode Forward Voltage
V_{SWCE}	Switch Voltage Drop
$I_{pk(SW)}$	Peak Switch Current
D	Duty Cycle
L	Inductor Value
f	Switching Frequency

Line regulation curve in Figure 24 illustrates three distinct regions; in the first region, the peak current to the switch is exceeded tripping the overcurrent protection and causing the regulated current to drop, Region 2 is where the current

is flat and represents normal operation, Region 3 occurs when V_{IN} is greater than V_{OUT} and there is no longer constant current regulation. Region 3 and 1 are included here for illustrative purposes as this is not a normal mode of operation.

Figure 9 illustrates the additional circuitry required to support 12 V_{AC} input signal which includes the addition of a bridge rectifier and input filter capacitor. The rectified dc voltage is

$$V_{INDC} = \sqrt{2} * V_{AC} \approx 17 V_{DC}$$

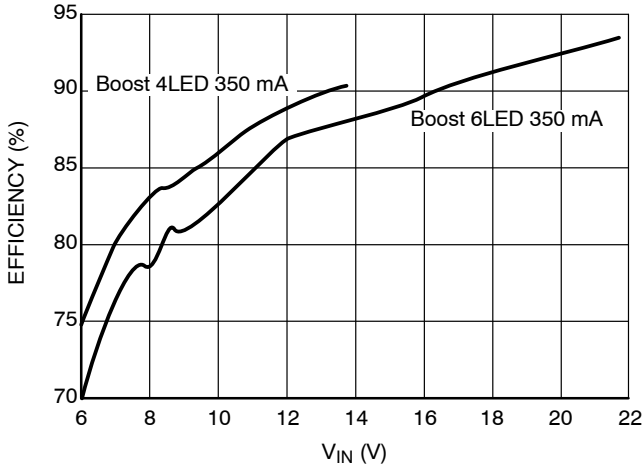

Figure 23. Boost Converter Efficiency for 4 or 6 LEDs and Output Current 350 mA

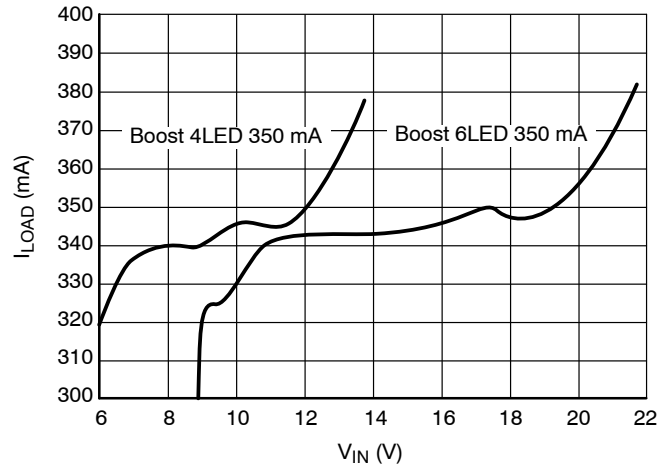

Figure 24. Line Regulation for 4 or 6 LEDs and Output Current 350 mA

Table 12. NCP3065 BOOST BILL OF MATERIALS

Qty	Reference	Part Description	Mfg P/N	Mfg	Package	Mtg
1	C1	100 μ F/50 V, Electrolytic Capacitor	EEEVFK1H101P	Panasonic	F, 8x10.2	SMD
2	C2,C5	100 nF, Ceramic Capacitor			1206	SMD
1	C3	220 μ F/50 V, Electrolytic Capacitor	EEEVFK1H221P	Panasonic	G, 10x10.2	SMD
1	C4	2.2 nF, Ceramic Capacitor			0805	SMD
1	D1	1 A, 40 V Schottky Rectifier	MBRS140LT3G	ON Semiconductor	SMB	SMD
1	D2	Zener Diode, 36 V	MM3Z36VT1G	ON Semiconductor	SOD123	SMD
1	L1	Surface mount power inductor	DO3340P-104MLD	Coilcraft		SMD
1	Q2	General purpose transistor	BC817-LT1G	ON Semiconductor	SOT23	SMD
1	R1	150 m Ω , 0.5 W			2010	SMD
1	R8	1k, Resistor			0805	SMD
1	R9	680 m Ω , \pm 1%			1206	SMD
2	R10	1.2 k Ω , Resistor			0805	SMD
1	U1	DC-DC Controller	NCP3065	ON Semiconductor	SOIC8	SMD

AND8298

Conclusion

LEDs are replacing traditional incandescent and halogen lighting sources in architectural, industrial, residential and the transportation lighting. The key challenge in powering LED's is providing a constant current source. The demo board for the NCP3065/NCV3065 can be easily configured

for a variety of constant current buck and boost LED driver applications. In addition there is an EXCEL tool at the ON Semiconductor website for calculating inductor and other passive components if the design requirements differ from the specific application voltages and currents illustrated in these example.

ON Semiconductor and  are registered trademarks of Semiconductor Components Industries, LLC (SCILLC). SCILLC reserves the right to make changes without further notice to any products herein. SCILLC makes no warranty, representation or guarantee regarding the suitability of its products for any particular purpose, nor does SCILLC assume any liability arising out of the application or use of any product or circuit, and specifically disclaims any and all liability, including without limitation special, consequential or incidental damages. "Typical" parameters which may be provided in SCILLC data sheets and/or specifications can and do vary in different applications and actual performance may vary over time. All operating parameters, including "Typicals" must be validated for each customer application by customer's technical experts. SCILLC does not convey any license under its patent rights nor the rights of others. SCILLC products are not designed, intended, or authorized for use as components in systems intended for surgical implant into the body, or other applications intended to support or sustain life, or for any other application in which the failure of the SCILLC product could create a situation where personal injury or death may occur. Should Buyer purchase or use SCILLC products for any such unintended or unauthorized application, Buyer shall indemnify and hold SCILLC and its officers, employees, subsidiaries, affiliates, and distributors harmless against all claims, costs, damages, and expenses, and reasonable attorney fees arising out of, directly or indirectly, any claim of personal injury or death associated with such unintended or unauthorized use, even if such claim alleges that SCILLC was negligent regarding the design or manufacture of the part. SCILLC is an Equal Opportunity/Affirmative Action Employer. This literature is subject to all applicable copyright laws and is not for resale in any manner.

PUBLICATION ORDERING INFORMATION

LITERATURE FULFILLMENT:

Literature Distribution Center for ON Semiconductor
P.O. Box 5163, Denver, Colorado 80217 USA
Phone: 303-675-2175 or 800-344-3860 Toll Free USA/Canada
Fax: 303-675-2176 or 800-344-3867 Toll Free USA/Canada
Email: orderlit@onsemi.com

N. American Technical Support: 800-282-9855 Toll Free
USA/Canada
Europe, Middle East and Africa Technical Support:
Phone: 421 33 790 2910
Japan Customer Focus Center
Phone: 81-3-5773-3850

ON Semiconductor Website: www.onsemi.com
Order Literature: <http://www.onsemi.com/orderlit>
For additional information, please contact your local
Sales Representative

AND8298/D