

LM5025A Evaluation Board

National Semiconductor
Application Note 1345
Robert Bell
December 2004



Introduction

The LM5025A evaluation board is designed to provide the design engineer with a fully functional power converter based on the Active Clamp Forward topology to evaluate the LM5025A controller. The evaluation board is provided in an industry standard half-brick footprint.

The performance of the evaluation board is as follows:

- Input range: 36V to 78V (100V peak)
- Output voltage: 3.3V
- Output current: 0 to 30A
- Measured efficiency: 90.5% at 30A, 92.5% at 15A
- Frequency of operation: 230kHz
- Board size: 2.3 x 2.4 x 0.5 inches
- Load Regulation: 1%
- Line Regulation: 0.1%
- Line UVLO, Hiccup Current Limit

The printed circuit board consists of 4 layers of 3 ounce copper on FR4 material with a total thickness of 0.050 inches. Soldermask has been omitted from some areas to facilitate cooling. The unit is designed for continuous operation at rated load at $< 40^{\circ}\text{C}$ and a minimum airflow of 200 CFM.

Theory of Operation

Power converters based on the Forward topology offer high efficiency and good power handling capability in applications up to several hundred Watts. The operation of the transformer in a forward topology does not inherently self-reset each power switching cycle, a mechanism to reset the transformer is required. The active clamp reset mechanism is

presently finding extensive use in medium level power converters in the 50 to 200W range.

The Forward converter is derived from the Buck topology family, employing a single modulating power switch. The main difference between the topologies are, the Forward topology employs a transformer to provide input / output ground isolation and a step down or step up function.

Each cycle, the main primary switch turns on and applies the input voltage across the primary winding, which has 12 turns. The transformer secondary has 2 turns, leading to a 6:1 step-down of the input voltage. For an output voltage of 3.3V the required duty cycle (D) of the main switch must vary from approximately 60% (low line) to 25% (high line). The clamp capacitor along with the reset switch reverse biases the transformer primary each cycle when the main switch turns off. This reverse voltage resets the transformer. The clamp capacitor voltage is $V_{in} / (1-D)$.

The secondary rectification employs self-driven synchronous rectification to maintain high efficiency and ease of drive.

Feedback from the output is processed by an amplifier and reference, generating an error voltage, which is coupled back to the primary side control through an optocoupler. The LM5025A voltage mode controller pulse width modulates the error signal with a ramp signal derived from the input voltage. Deriving the ramp signal slope from the input voltage provides line feed-forward, which improves line transient rejection. The LM5025A also provides a controlled delay necessary for the reset switch.

The evaluation board can be synchronized to an external clock with a recommended frequency range of 190 to 300KHz.

Theory of Operation (Continued)

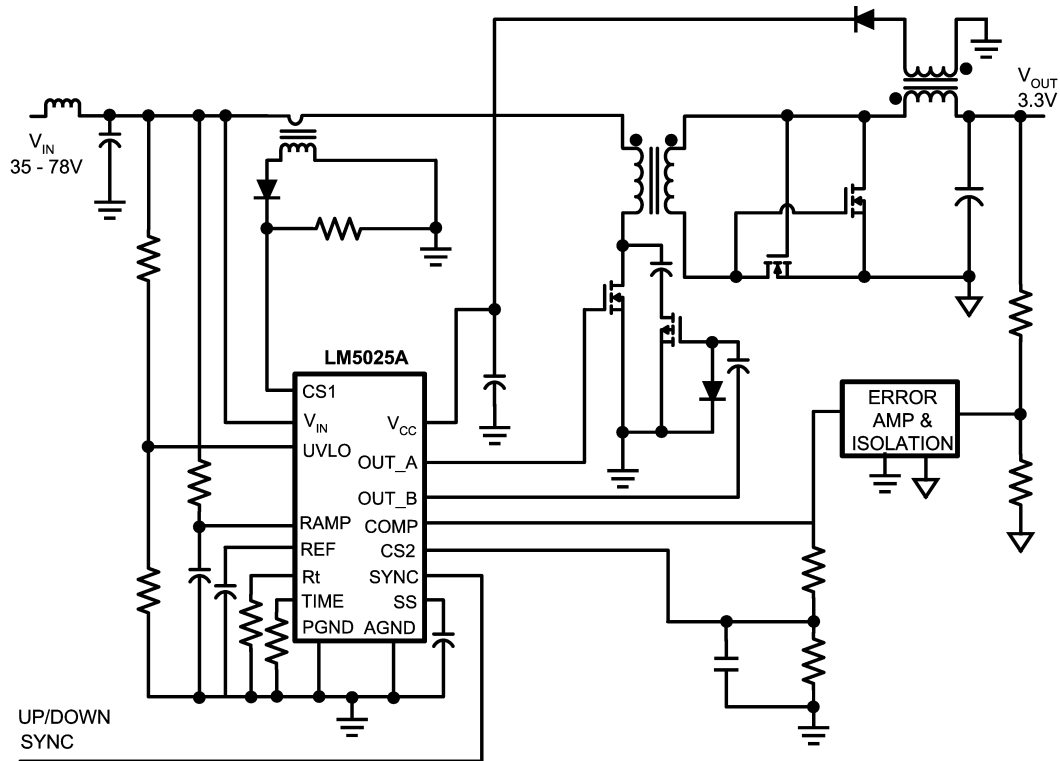

Simplified Active Clamp Forward Converter

20127601

Powering and Loading Considerations

When applying power to the LM5025A evaluation board certain precautions need to be followed. A failure or mis-connection can present itself in a very alarming manner.

Proper Connections

When operated at low input voltages the UUT can draw up to 3.5A of current at full load. The maximum rated output current for the evaluation board is 30A. Be sure to choose the correct connector and wire size when attaching the source supply and the load. Monitor the current into and out of the UUT (evaluation board or unit under test). Monitor the voltage directly at the output terminals of the UUT. The voltage drop across the load connecting wires will give inaccurate measurements, this is especially true for accurate efficiency measurements.

Source Power

The evaluation board can be viewed as a constant power load. At low input line voltage (35V) the input current can reach 3.5A, while at high input line voltage (78V) the input current will be approximately 1.5A. Therefore to fully test the LM5025A evaluation board a DC power supply capable of at least 80V and 4A is required. The power supply must have adjustments for both voltage and current. An accurate read-out of output current is desirable since the current is not subject to loss in the cables as voltage is.

The power supply and cabling must present a low impedance to the UUT. Insufficient cabling or a high impedance

power supply will droop during power supply application with the UUT inrush current. If large enough, this droop will cause a chattering condition upon power up. This chattering condition is an interaction with the UUT undervoltage lockout, the cabling impedance and the inrush current

Loading

An appropriate electronic load with specified operation down to 3.0V minimum is desirable. The resistance of a maximum load is 0.11Ω. You need thick cables! Consult a wire chart if needed. If resistor banks are used there are certain precautions to be taken. The wattage and current ratings must be adequate for a 30A, 100W supply. Monitor both current and voltage at all times.

Be careful!! The high temperatures reached by even the most adequately rated resistors may burn you or melt your benchtop.

Air Flow

Full rated power should never be attempted without providing the specified 200 CFM of air flow over the evaluation board. This can be provided by a stand-alone fan.

Powering Up

Using the shutdown pin provided will allow powering up the source supply with the current level set low. It is suggested that the load be kept low during the first power up. Set the current limit of the source supply to provide about 1.5 times

Powering Up (Continued)

the wattage of the load. As you remove the connection from the shutdown pin to ground, immediately check for 3.3 volts at the output.

A most common occurrence, that will prove unnerving, is when the current limit set on the source supply is insufficient for the load. The result is similar to having the high source impedance referred to earlier. The interaction of the source supply folding back and the UUT going into undervoltage shutdown will start an oscillation, or chatter, that may have highly undesirable consequences. A quick efficiency check is the best way to confirm that everything is operating properly. If something is amiss you can be reasonably sure that it will

affect the efficiency adversely. Few parameters can be incorrect in a switching power supply without creating losses and potentially damaging heat.

Over Current Protection

The evaluation board is configured with delayed hiccup over-current protection. In the event of an output overload (approximately 33A) the unit will discharge the softstart capacitor, which disables the power stage. After a delay the softstart is released. The shutdown, delay and slow recharge time of the softstart capacitor protects the unit, especially during short circuit event where the stress is highest.

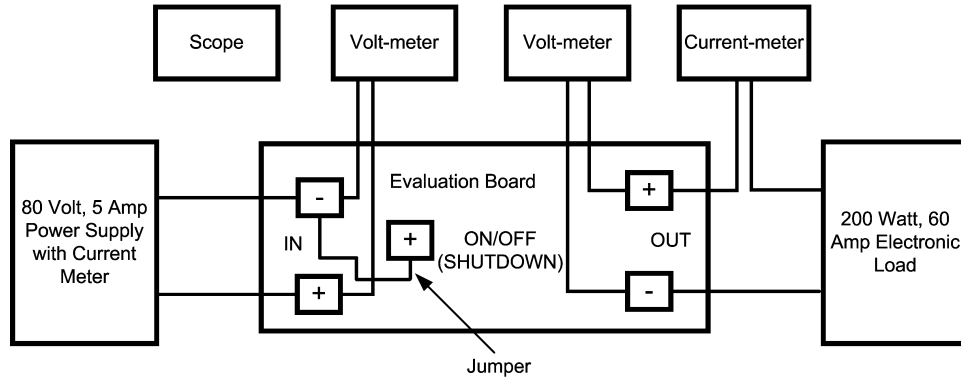

Typical Evaluation Setup

20127602

Performance Characteristics

TURN-ON WAVEFORMS

When applying power to the LM5025A evaluation board a certain sequence of events must occur. Soft-start capacitor values and other components allow the feedback loop to stabilize without overshoot. *Figure 1* shows the output voltage during a typical start-up with a 48V input and a load of 5A. There is no overshoot during startup.

OUTPUT RIPPLE WAVEFORMS

Figure 2 shows the transient response for a load of change from 5A to 25A. The upper trace shows output voltage droop and overshoot during the sudden change in output current shown by the lower trace.

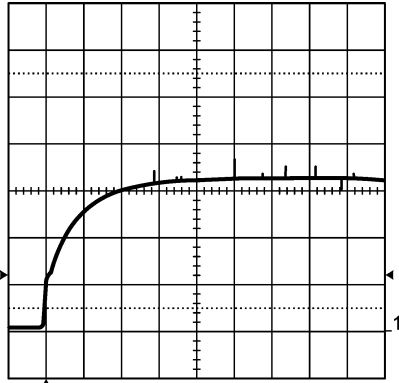

20127607
 Conditions: Input Voltage = 48VDC Output Current = 5A
 Trace 1: Output Voltage Volts/div = 0.5V
 Horizontal Resolution = 1msec/div

FIGURE 1.

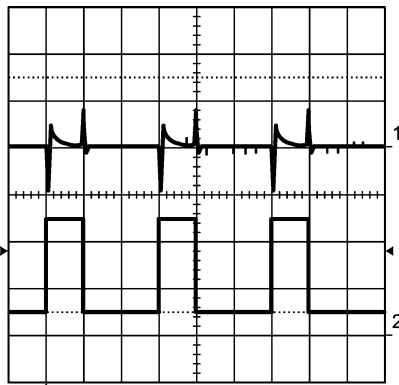

20127608
 Conditions: Input Voltage = 48VDC Output Current = 5A to 25A
 Trace 1: Output Voltage Volts/div = 0.5V
 Trace 2: Output Current, Amps/div = 10.0A
 Horizontal Resolution = 1μs/div

FIGURE 2.

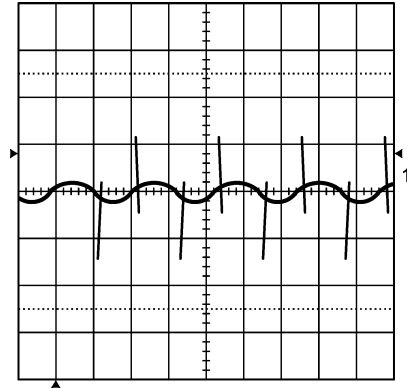

20127609
 Conditions: Input Voltage = 48VDC
 Output Current = 30A
 Bandwidth Limit = 25MHz
 Trace 1: Output Ripple Voltage Volts/div = 50mV
 Horizontal Resolution = 2μs/div

FIGURE 3.

Figure 3 shows typical output ripple seen directly across the output capacitor, for an input voltage of 48V and a load of 30A. This waveform is typical of most loads and input voltages.

Figure 4 and *Figure 5* show the drain voltage of Q1 with a 25A load. *Figure 4* represents an input voltage of 38V and *Figure 5* represents an input voltage of 78V.

Figure 6 shows the gate voltages of the synchronous rectifiers. The drive from the main power transformer is delayed slightly at turn-on by a resistor interacting with the gate capacitance. This provides improved switching transitions for optimum efficiency. The difference in drive voltage is inherent in the topology and varies with line voltage.

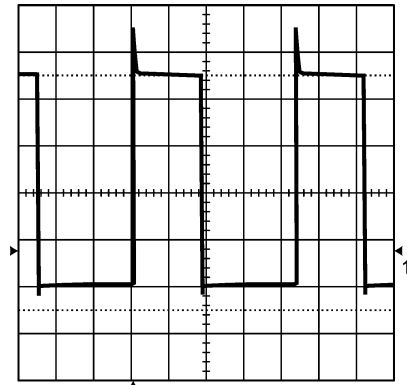

20127604
 Conditions: Input Voltage = 38VDC Output Current = 25A
 Trace 1: Q1 drain voltage Volts/div = 20V Horizontal Resolution = 1μs/div

FIGURE 4.

Performance Characteristics

(Continued)

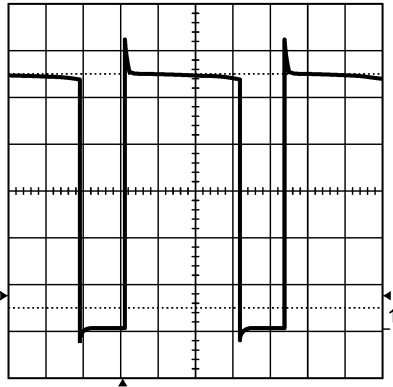

20127605

Conditions: Input Voltage = 78VDC Output Current = 25A
Trace 1: Q1 drain voltage Volts/div = 20V Horizontal Resolution = 1 μ s/div

FIGURE 5.

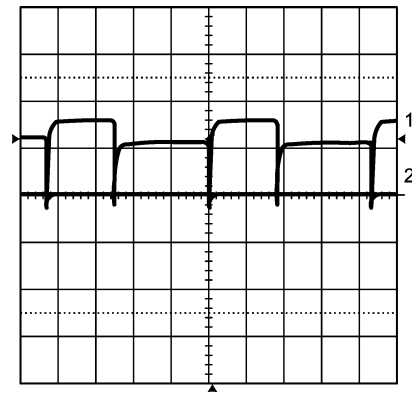

20127606

Conditions: Input Voltage = 48VDC Output Current = 5A
Synchronous rectifier, Q3 gate Volts/div = 5V
Trace 1: Synchronous rectifier, Q3 gate Volts/div = 5V
Trace 2: Synchronous rectifier, Q5 gate Volts/div = 5V
Horizontal Resolution = 1 μ s/div

FIGURE 6.

Application Circuit

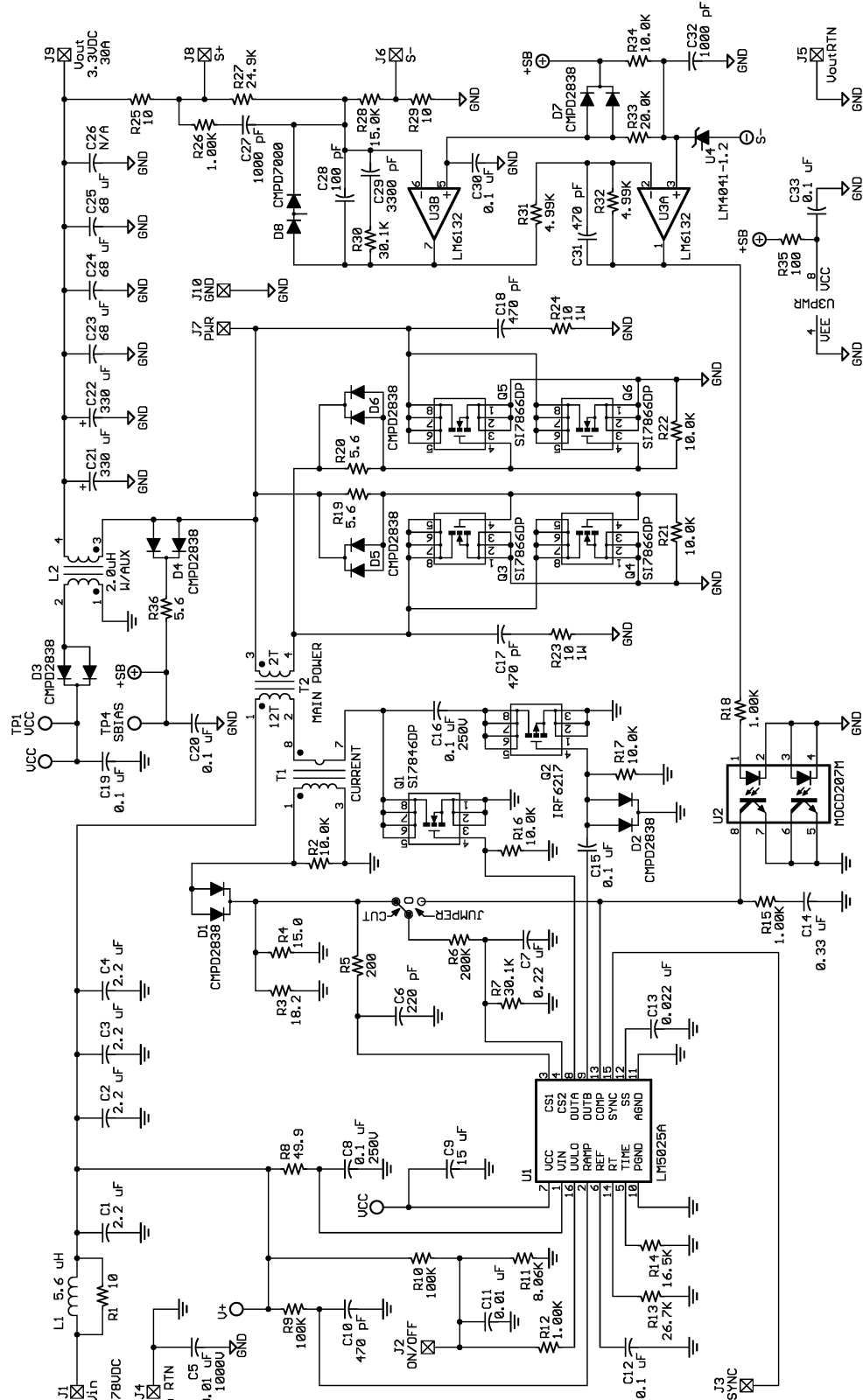

Application Circuit: Input 36 to 78V, Output 3.3V, 30A

20127603

Layout and Bill of Materials

The Bill of Materials is shown below and includes the manufacturer and part number. The layers of the printed circuit board are shown in top down order. View is from the top

down except for the bottom silkscreen which is shown viewed from the bottom. Scale is approximately X1.5. The printed circuit board consists of 4 layers of 3 ounce copper on FR4 material with a total thickness of 0.050 inches.

Bill of Materials

DESIGNATOR	QTY	PART NUMBER	DESCRIPTION	VALUE
C1-C4	4	C4532X7R2A225M	CAPACITOR, CER, TDK	2.2u, 100V
C5	1	C4532X7R3A103K	CAPACITOR, CER, TDK	0.01μ, 1000V
C6	1	C0805C221J5GAC	CAPACITOR, CER, KEMET	220p, 50V
C7	1	C2012X7R1E224K	CAPACITOR, CER, TDK	0.22μ, 25V
C8,C16	2	C3216X7R2E104K	CAPACITOR, CER, TDK	0.1μ, 250V
C9	1	C4532X7R1E156M	CAPACITOR, CER, TDK	15μ, 25V
C10,C17,C18, C31	4	C0805C471J5GAC	CAPACITOR, CER, KEMET	470p, 50V
C11	1	C2012X7R2A103K	CAPACITOR, CER, TDK	0.01μ, 100V
C12,C15,C30, C33	4	C2012X7R1H104K	CAPACITOR, CER, TDK	0.1μ, 50V
C13	1	C2012X7R2A223K	CAPACITOR, CER, TDK	0.022μ, 100V
C14	1	C3216X7R1H334K	CAPACITOR, CER, TDK	0.33μ, 50V
C19,C20	2	C1206C104K5RAC	CAPACITOR, CER, KEMET	0.1μ, 50V
C21,C22	2	T520D337M006AS4350	CAPACITOR,TANT, KEMET	330μ, 6.3V
C23,C24,C25	3	C4532X7S0G686M	CAPACITOR, CER, TDK	68μ, 4V
C26		OPEN	NOT USED	
C27,C32	2	C2012X7R2A102K	CAPACITOR, CER, TDK	1000p, 100V
C28	1	C0805C101J5GAC	CAPACITOR, CER, KEMET	100p, 50V
C29	1	C2012X7R2A332K	CAPACITOR, CER, TDK	3300p, 100V
D1- D8	8	CMPD2838-NSA	DIODE, SIGNAL, CENTRAL	
L1	1	SLF10145T-5R6M3R2	INPUT CHOKE, TDK	5.6μH, 3.5A
L2	1	B0358-C	CHOKE with AUX, COILCRAFT	2μH, 33A
Q1	1	SI7846DP	N-FET, SILICONIX	150V, 50m
Q2	1	IRF6217	P-FET, IR	150V, 2.4
Q3 - Q6	4	SI7866DP	FET, SILICONIX	20V, 3m
R1,R25,R29	3	CRCW120610R0F	RESISTOR	10
R2,R16,R17, R21,R22, R34	6	CRCW12061002F	RESISTOR	10K
R19,R20, R36	3	CRCW12065R60F	RESISTOR	5.6

Layout and Bill of Materials (Continued)**Bill of Materials** (Continued)

DESIGNATOR	QTY	PART NUMBER	DESCRIPTION	VALUE
R4	1	CRCW120615R0F	RESISTOR	15
R5	1	CRCW12062000F	RESISTOR	200
R6	1	CRCW12062003F	RESISTOR	200K
R8	1	CRCW120649R9F	RESISTOR	49.9
R9,R10	2	CRCW12061003F	RESISTOR	100K
R3	1	CRCW120618R2F	RESISTOR	18.2
R7	1	CRCW12063012F	RESISTOR	30.1K
R11	1	CRCW12068061F	RESISTOR	8.06K
R12,R15,R18,R26	4	CRCW12061001F	RESISTOR	1K
R13	1	CRCW12062672F	RESISTOR	26.7K
R14	1	CRCW12061652F	RESISTOR	16.5K
R23,R24	2	CRCW2512100J	RESISTOR	10, 1W
R27	1	CRCW12062492F	RESISTOR	24.9K
R28	1	CRCW12061502F	RESISTOR	15K
R30	1	CRCW12063012F	RESISTOR	30.1K
R31,R32	2	CRCW12064991F	RESISTOR	4.99K
R33	1	CRCW12062002F	RESISTOR	20K
R35	1	CRCW12061000F	RESISTOR	100
T1	1	P8208T	CURRENT XFR, PULSE ENG	100:1
T2	1	B0357-B	POWER XFR, COILCRAFT	12:02
U1	1	LM5025A	CONTROLLER, NATIONAL SEMI	
U2	1	M0CD207M	OPTO-COUPLER, QT OPTO	
U3	1	LM6132AIM	OPAMP, NATIONAL SEMI	
U4	1	LM4041CEM3-1.2	REFERENCE, NATIONAL SEMI	

PCB Layouts

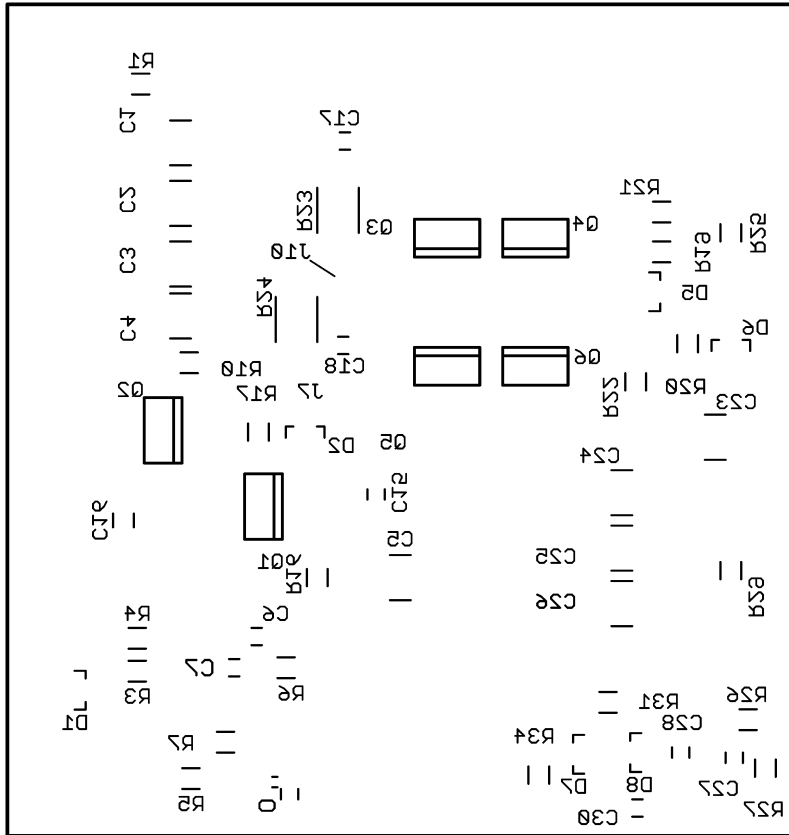

20127610

PCB Layouts (Continued)

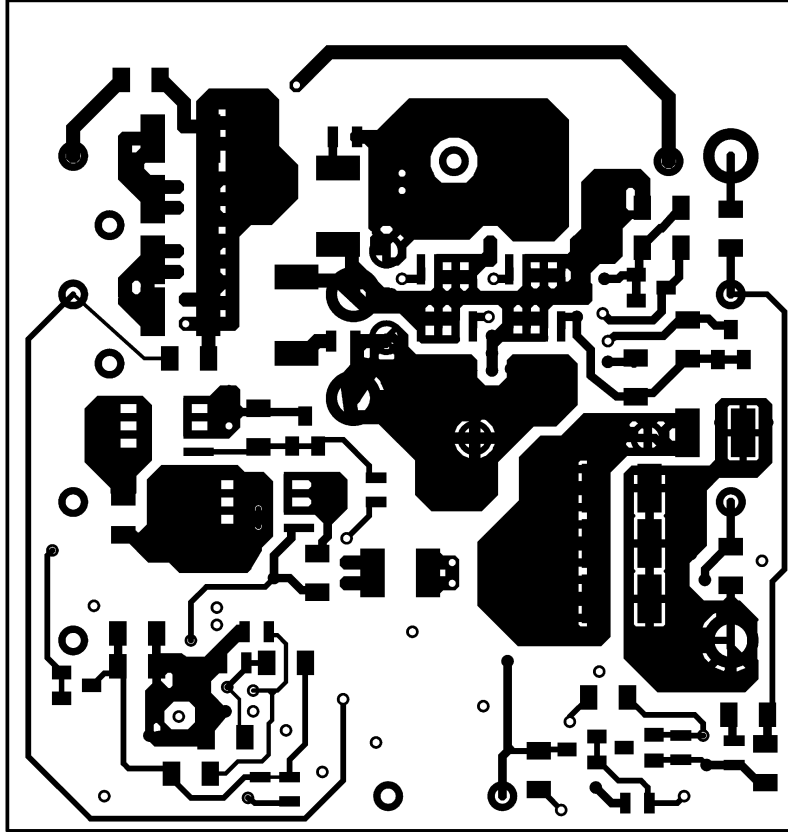

20127611

PCB Layouts (Continued)

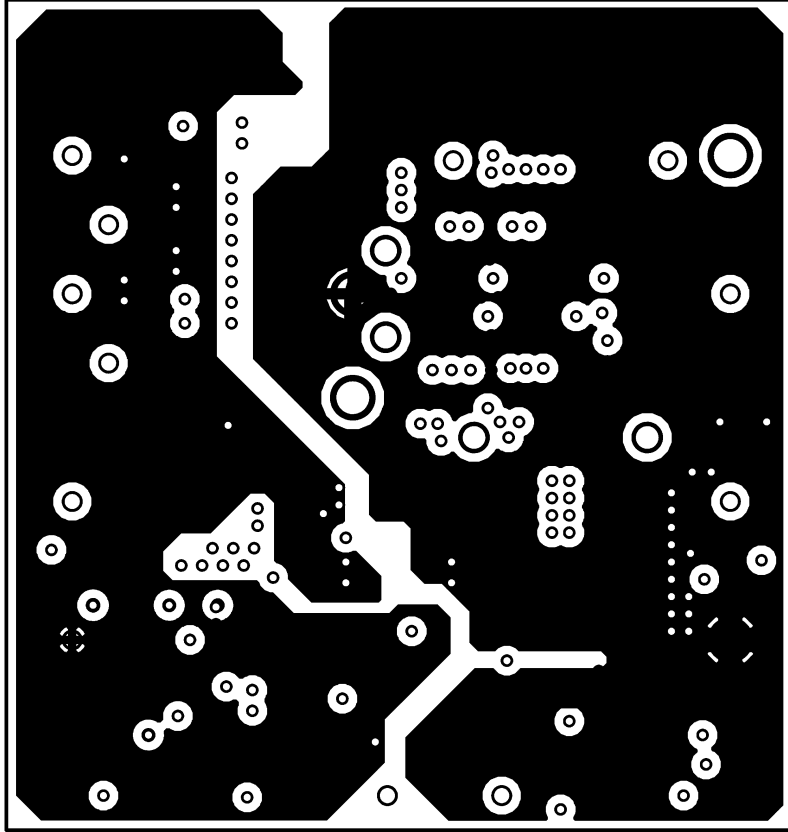

20127612

PCB Layouts (Continued)

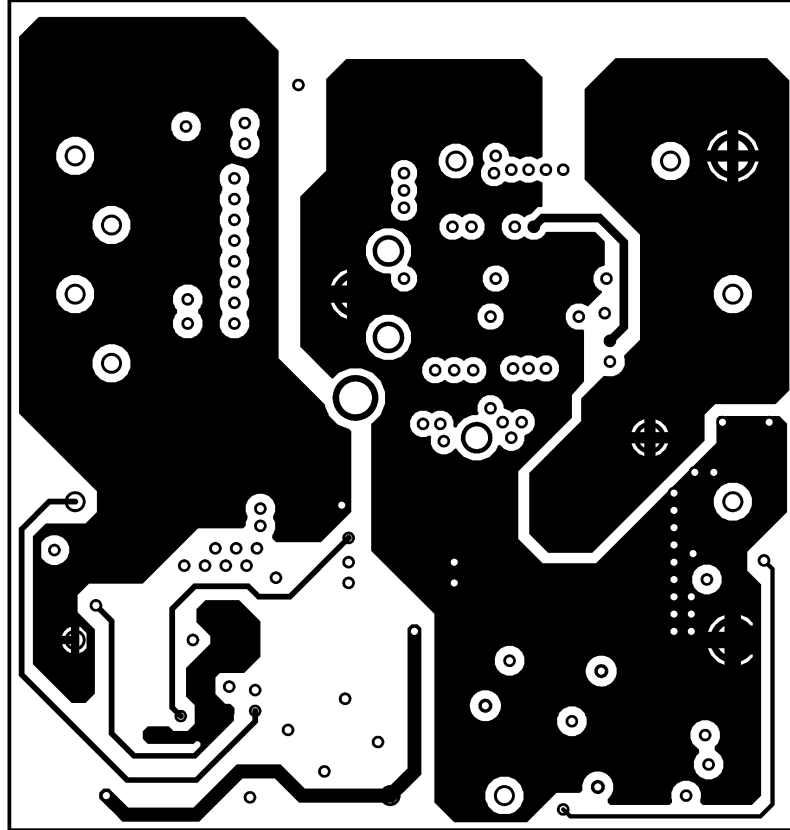

20127613

PCB Layouts (Continued)

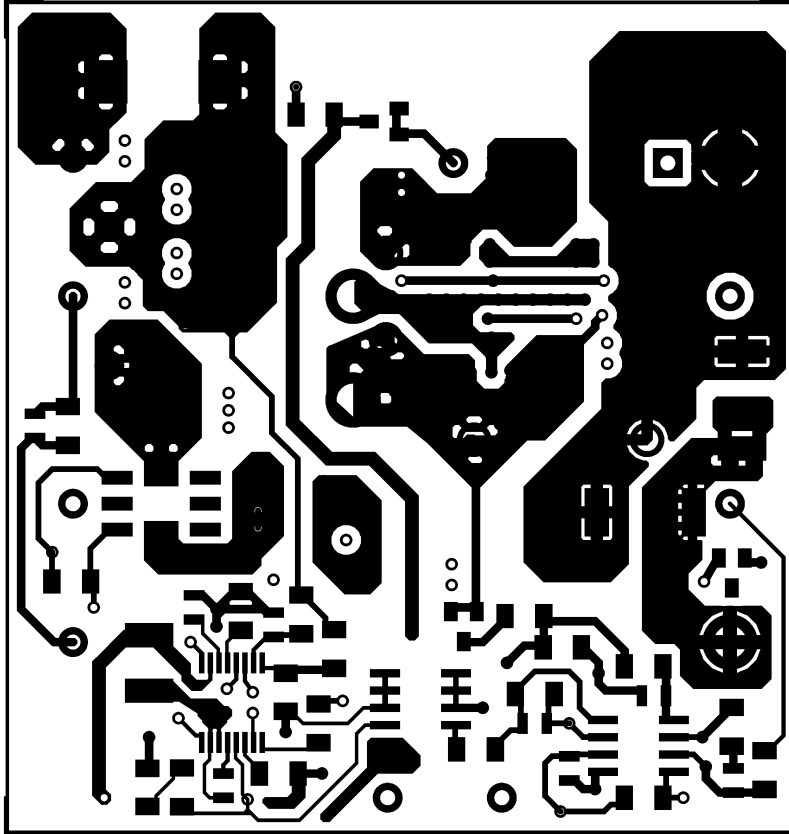

20127614

PCB Layouts (Continued)

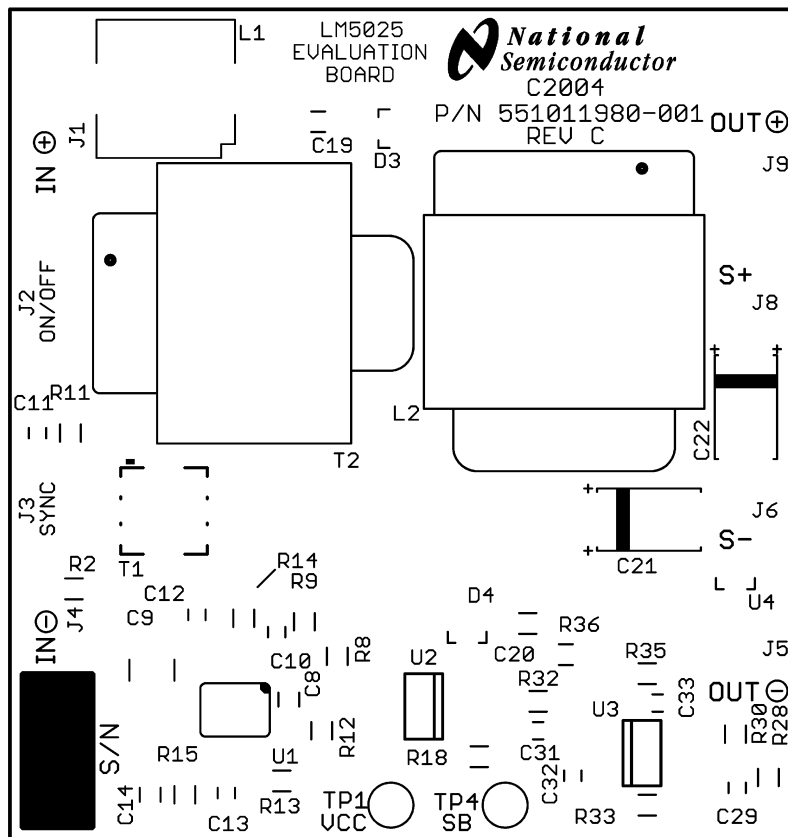

20127615

National does not assume any responsibility for use of any circuitry described, no circuit patent licenses are implied and National reserves the right at any time without notice to change said circuitry and specifications.

For the most current product information visit us at www.national.com.

LIFE SUPPORT POLICY

NATIONAL'S PRODUCTS ARE NOT AUTHORIZED FOR USE AS CRITICAL COMPONENTS IN LIFE SUPPORT DEVICES OR SYSTEMS WITHOUT THE EXPRESS WRITTEN APPROVAL OF THE PRESIDENT AND GENERAL COUNSEL OF NATIONAL SEMICONDUCTOR CORPORATION. As used herein:

1. Life support devices or systems are devices or systems which, (a) are intended for surgical implant into the body, or (b) support or sustain life, and whose failure to perform when properly used in accordance with instructions for use provided in the labeling, can be reasonably expected to result in a significant injury to the user.
2. A critical component is any component of a life support device or system whose failure to perform can be reasonably expected to cause the failure of the life support device or system, or to affect its safety or effectiveness.

BANNED SUBSTANCE COMPLIANCE

National Semiconductor certifies that the products and packing materials meet the provisions of the Customer Products Stewardship Specification (CSP-9-111C2) and the Banned Substances and Materials of Interest Specification (CSP-9-111S2) and contain no "Banned Substances" as defined in CSP-9-111S2.



National Semiconductor
Americas Customer Support Center
Email: new.feedback@nsc.com
Tel: 1-800-272-9959

National Semiconductor
Europe Customer Support Center
Fax: +49 (0) 180-530 85 86
Email: europa.support@nsc.com
Deutsch Tel: +49 (0) 69 9508 6208
English Tel: +44 (0) 870 24 0 2171
Français Tel: +33 (0) 1 41 91 8790

National Semiconductor
Asia Pacific Customer Support Center
Email: ap.support@nsc.com

National Semiconductor
Japan Customer Support Center
Fax: 81-3-5639-7507
Email: jpn.feedback@nsc.com
Tel: 81-3-5639-7560

www.national.com