

Quick Start Guide for a 0.5 Amp Buck Regulator Using The LM5574 and LM25574

National Semiconductor
Application Note 1563
January 2007



The LM5574 and LM25574 switching regulators feature all of the functions necessary to implement an efficient high voltage buck regulator using a minimum of external components. These easy to use regulators include either a 42V (LM25574) or a 75V (LM5574) N-Channel buck switch with an output current capability of 0.5 Amps. The operating frequency is programmable from 50kHz up to 1MHz. Protection features include: current limit, thermal shutdown and remote shutdown capability. The device is available in a TSSOP-16 package. This step-by-step guide provides an easy to use process to quickly select the external components necessary to com-

plete a design. More detailed information including theory of operation, design trade-offs and additional application guidance is available in the device datasheet. Shown below in Figure 1 is a complete schematic for a 0.5 Amp step-down DC-DC converter. Several external component values can be standardized for most applications. The input voltage range, output voltage and desired operating frequency dictate the remaining component values.

An Excel based spreadsheet derived from the guide is available on the National Semiconductor website.

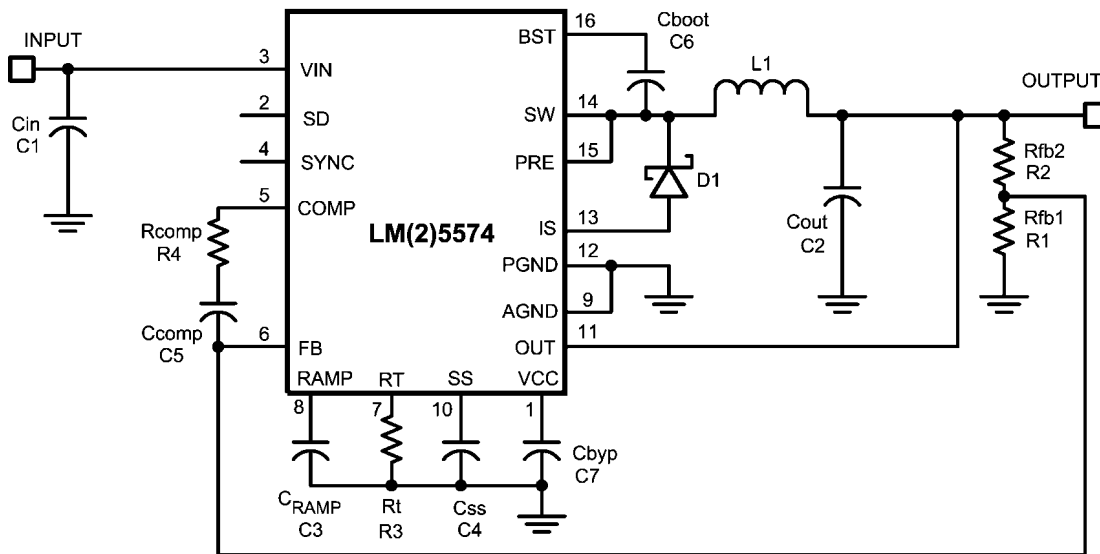

FIGURE 1. Application Schematic

Quick Guide Design Worksheet

Step 1. List the basic requirements:

Output Current: 0 to 0.5 Amp

Output Voltage: _____ V [1]

Input Voltage Min Spec: _____ V [2]

Input Voltage Max Spec: _____ V [3]

Step 2. If the Input Voltage Max Spec [3] is less than 42V use the LM25574. If the Input Voltage Max Spec [3] is greater than 42V but less than 75V use the LM5574. Both devices require the Input Voltage Min Spec [2] to be greater than 6V.

Selected Regulator: _____ [4]

Step 3. Selection of the operating frequency is a trade-off between the conversion efficiency and solution size. Operating at a high frequency, with a relatively high input voltage will severely impact the efficiency and consequently generate a lot of heat. In some applications, the selection of a high op-

erating frequency will limit the input voltage range. The recommended maximum operating frequency for applications using LM5574 is 500 KHz. When using the LM25574 the operating frequency may be set as high as 1MHz. Select a target operating frequency from 50 kHz to 1MHz (500kHz for the LM5574). Check to see if the Vin(min) limits the selected operating frequency:

$$F_{sw(max)} = \frac{V_{in(min)[2]} - (V_{out[1]} + 0.6)}{V_{in(min)[2]} \times 5.5 \times 10^{-7}}$$

The selected operating frequency must be less than Fsw(max) calculated above, if not reduce the operating frequency. Check to see if the Vin(max) limits the selected operating frequency:

$$F_{sw(max)} = \frac{(V_{out[1]} + 0.6)}{V_{in(max)[3]} \times 8 \times 10^{-8}}$$

The selected operating frequency must be less than Fsw (max) calculated above, if not reduce the operating frequency.

Selected operating frequency Fsw: _____ Hz [5]

Step 4. Calculate the value of Rt for the selected operating frequency.

$$R_t = \frac{1}{F_{sw}[5]} - 580 \times 10^{-9} \\ 135 \times 10^{-12}$$

Selected value for R1: _____ Ohms [6]

Step 5. Calculate the value of L1.

$$L_1 = \frac{V_{out}[1] \times (V_{in(max)}[3] - V_{out}[1])}{0.2 \times F_{sw}[6] \times V_{in(max)}[3]}$$

Select the nearest standard inductor value. During an overload condition the peak inductor current is limited to 0.7A nominal (0.8A maximum). The selected inductor must be rated for peak current of at least 0.8 Amps.

Selected value of L1: _____ Henrys [7]

Step 6. Calculate the value of C_{RAMP}:

$$C_{RAMP} = L_1[7] \times 5 \times 10^{-6}$$

Selected value of C_{RAMP}: _____ Farads [8]

Step 7. Set Rfb2 to 5kOhms if Vout[1] is less than or equal to 5 Volts. If Vout[1] is greater than 5V set Rfb2 to 10K Ohms.

Selected value of Rfb2: _____ Ohms [9]

Calculate the value of Rfb1:

$$R_{fb1} = \frac{1.225 \times R_{fb2}[9]}{(V_{out}[1] - 1.225)}$$

Selected value of Rfb1: _____ Ohms [10]

Step 8. Select the re-circulating diode, D1. A Schottky type diode is required for all applications. Ultra-fast diodes are not recommended and may result in damage to the IC due to reverse recovery current transients. The reverse breakdown rating should be greater than the Input Voltage Max Spec[3], plus some safety margin. For worst case design, assume a short circuit load condition. In this case the diode will carry the output current almost continuously. This current can be as high as 0.8A. Assuming a 0.6V drop across the diode, the maximum diode power dissipation can be as high as 0.5W. An SMA case or similar package is recommended.

Selected diode part number: _____ [11]

Step 9. A good quality input capacitor(s) is necessary to limit the ripple voltage at the VIN pin while supplying most of the switch current during the on-time. The minimum RMS ripple current rating for the input capacitor(s) is 0.25 Amp. A quality ceramic capacitor with a low ESR is recommended. The input capacitor voltage rating should be greater than the Input Voltage Max Spec [3], plus some safety margin. A guide to select the input capacitor(s) value in proportion to the operating frequency is:

$$C_{in} = \frac{0.25}{F_{sw}[5]}$$

Selected value for Cin: _____ Farads [12]

Step 10. The output capacitor smoothes the inductor ripple current and provide a source of charge for transient loading conditions. A good choice for the output capacitor is to use a ceramic capacitor (2.2 μF to 47 μF). Ceramic capacitors provides ultra low ESR necessary to reduce the output ripple voltage and noise spikes. The output capacitor voltage rating should be greater than the Output Voltage Spec [1], plus some safety margin. An approximation for the output ripple voltage is:

$$\Delta V_{out} = 0.2 \times \left(ESR + \frac{1}{8 \times F_{sw}[5] \times C_{out}} \right)$$

Selected value for Cout: _____ Farads [13]

Step 11. Ccomp and Rcomp configure the error amplifier gain characteristics to accomplish a stable overall loop gain. One advantage of current mode control is the ability to close the loop with only two feedback components. Calculate the value of Rcomp:

$$R_{comp} = 2.5 \times 10^5 \times R_{fb1}[9] \times C_{out}[13] + \left(\frac{R_{fb1}[9]}{V_{out}[1]} \right)$$

Selected value of Rcomp: _____ Ohms [14]

Calculate the value of Ccomp

$$C_{comp} = \frac{1}{8 \times 10^3 \times R_{comp}[14]}$$

Selected value of Ccomp: _____ Farads [15]

Step 12. Shown in the following table is the Bill of Materials for your design. Transcribe each value [#] from worksheet above into the following table. Congratulations, you're done.

SCH REF	PART NUMBER	DESCRIPTION	VALUE	WORK SHEET REF
C1 (Cin)		INPUT CAPACITOR		[12]
C2 (Cout)		OUTPUT CAPACITOR		[13]
C3 (CRAMP)		RAMP CAPACITOR		[8]
C4 (C _{ss})	C2012X7R2A103K	CAPACITOR, TDK	0.01 μ	--
C5 (C _{comp})		COMPENSATION CAP		[15]
C6 (C _{boot})	C2012X7R2A223K	CAPACITOR, TDK	0.022 μ	--
C7 (C _{byp})	C2012X7R1C474M	CAPACITOR, TDK	0.47 μ , 16V	--
D1		SCHOTTKY DIODE		[11]
L1		INDUCTOR		[7]
R1 (R _{fb1})		Feedback RESISTOR		[10]
R2 (R _{fb2})		Feedback RESISTOR		[9]
R3 (R _t)		TIMING RESISTOR		[6]
R4 (R _{comp})		COMPENSATION RESISTOR		[14]
U1		REGULATOR, NATIONAL		[4]

Notes

THE CONTENTS OF THIS DOCUMENT ARE PROVIDED IN CONNECTION WITH NATIONAL SEMICONDUCTOR CORPORATION ("NATIONAL") PRODUCTS. NATIONAL MAKES NO REPRESENTATIONS OR WARRANTIES WITH RESPECT TO THE ACCURACY OR COMPLETENESS OF THE CONTENTS OF THIS PUBLICATION AND RESERVES THE RIGHT TO MAKE CHANGES TO SPECIFICATIONS AND PRODUCT DESCRIPTIONS AT ANY TIME WITHOUT NOTICE. NO LICENSE, WHETHER EXPRESS, IMPLIED, ARISING BY ESTOPPEL OR OTHERWISE, TO ANY INTELLECTUAL PROPERTY RIGHTS IS GRANTED BY THIS DOCUMENT.

TESTING AND OTHER QUALITY CONTROLS ARE USED TO THE EXTENT NATIONAL DEEMS NECESSARY TO SUPPORT NATIONAL'S PRODUCT WARRANTY. EXCEPT WHERE MANDATED BY GOVERNMENT REQUIREMENTS, TESTING OF ALL PARAMETERS OF EACH PRODUCT IS NOT NECESSARILY PERFORMED. NATIONAL ASSUMES NO LIABILITY FOR APPLICATIONS ASSISTANCE OR BUYER PRODUCT DESIGN. BUYERS ARE RESPONSIBLE FOR THEIR PRODUCTS AND APPLICATIONS USING NATIONAL COMPONENTS. PRIOR TO USING OR DISTRIBUTING ANY PRODUCTS THAT INCLUDE NATIONAL COMPONENTS, BUYERS SHOULD PROVIDE ADEQUATE DESIGN, TESTING AND OPERATING SAFEGUARDS.

EXCEPT AS PROVIDED IN NATIONAL'S TERMS AND CONDITIONS OF SALE FOR SUCH PRODUCTS, NATIONAL ASSUMES NO LIABILITY WHATSOEVER, AND NATIONAL DISCLAIMS ANY EXPRESS OR IMPLIED WARRANTY RELATING TO THE SALE AND/OR USE OF NATIONAL PRODUCTS INCLUDING LIABILITY OR WARRANTIES RELATING TO FITNESS FOR A PARTICULAR PURPOSE, MERCHANTABILITY, OR INFRINGEMENT OF ANY PATENT, COPYRIGHT OR OTHER INTELLECTUAL PROPERTY RIGHT.

LIFE SUPPORT POLICY

NATIONAL'S PRODUCTS ARE NOT AUTHORIZED FOR USE AS CRITICAL COMPONENTS IN LIFE SUPPORT DEVICES OR SYSTEMS WITHOUT THE EXPRESS PRIOR WRITTEN APPROVAL OF THE CHIEF EXECUTIVE OFFICER AND GENERAL COUNSEL OF NATIONAL SEMICONDUCTOR CORPORATION. As used herein:

Life support devices or systems are devices which (a) are intended for surgical implant into the body, or (b) support or sustain life and whose failure to perform when properly used in accordance with instructions for use provided in the labeling can be reasonably expected to result in a significant injury to the user. A critical component is any component in a life support device or system whose failure to perform can be reasonably expected to cause the failure of the life support device or system or to affect its safety or effectiveness.

National Semiconductor and the National Semiconductor logo are registered trademarks of National Semiconductor Corporation. All other brand or product names may be trademarks or registered trademarks of their respective holders.

Copyright© 2007 National Semiconductor Corporation

For the most current product information visit us at www.national.com



National Semiconductor Americas Customer Support Center
Email: new.feedback@nsc.com
Tel: 1-800-272-9959

National Semiconductor Europe Customer Support Center
Fax: +49 (0) 180-530-85-86
Email: europe.support@nsc.com
Deutsch Tel: +49 (0) 69 9508 6208
English Tel: +49 (0) 870 24 0 2171
Français Tel: +33 (0) 1 41 91 8790

National Semiconductor Asia Pacific Customer Support Center
Email: ap.support@nsc.com

National Semiconductor Japan Customer Support Center
Fax: 81-3-5639-7507
Email: jpn.feedback@nsc.com
Tel: 81-3-5639-7560