

STEVAL-ISA018V1 demonstration board based on resonant half-bridge SMPS for industrial applications

Introduction

This user manual describes a high efficiency solution for industrial power supplies with a continuous output power of 150 W and peak power up to 240 W. It takes advantage of the resonant approach to minimize switching losses, resulting in higher than 90% efficiency. The topology is based on half-bridge and operated in a resonant fashion by means of a resonant LC tank, driven by the L6599 dedicated controller.

The board provides one regulated output, $V_O=24\text{ V}$ with $I_O=6\text{ A}$, and an overload capability of up to $I_O=10\text{ A}$. Output voltage and current are controlled by the TSM1011 constant voltage and constant current controller, providing square output regulation, while the overload is managed by thermal protection (PTC) on the output rectifiers.

The board, shown in [Figure 1](#), is obtainable using the order code STEVAL-ISA018V1.

Figure 1. STEVAL-ISA018V1 board prototype



Contents

1	Demonstration board description	4
2	Experimental waveforms	12
3	EMI measurements	15
4	Conclusions	16
5	Revision history	17

List of figures

Figure 1.	STEVAL-ISA018V1 board prototype	1
Figure 2.	Schematic	5
Figure 3.	Resonant transformer: pinout	6
Figure 4.	Resonant transformer: mechanical drawing	7
Figure 5.	STEVAL-ISA018V1 board layout with tracks	7
Figure 6.	Midpoint voltage and transformer current - $V_{in} = 230 \text{ Vac}$, $V_{out} = 24.6 \text{ V}$, $I_{out} = 2 \text{ A}$ (CH1: HB midpoint voltage; CH2: transformer current)	12
Figure 7.	Midpoint voltage and transformer current - $V_{in} = 230 \text{ Vac}$, $V_{out} = 24.6 \text{ V}$, $I_{out} = 2 \text{ A}$ (CH1: HB midpoint voltage; CH2: transformer current)	12
Figure 8.	Midpoint voltage and transformer current - $V_{in} = 230 \text{ Vac}$, $V_{out} = 24.6 \text{ V}$, $I_{out} = 2 \text{ A}$ (CH1: HB midpoint voltage; CH2: transformer current)	13
Figure 9.	Midpoint voltage and transformer current - $V_{in} = 230 \text{ Vac}$, $V_{out} = 24.6 \text{ V}$, $I_{out} = 2 \text{ A}$ (CH1: HB midpoint voltage; CH2: transformer current)	13
Figure 10.	Midpoint voltage and transformer current - $V_{in} = 230 \text{ Vac}$, $V_{out} = 24.6 \text{ V}$, $I_{out} = 2 \text{ A}$ (CH1: HB midpoint voltage; CH2: transformer current)	14
Figure 11.	Conducted emissions - phase - $V_{in} = 230 \text{ Vac}$, $I_{out} = 6 \text{ A}$	15
Figure 12.	Conducted emissions - neutral - $V_{in} = 230 \text{ Vac}$, $I_{out} = 6 \text{ A}$	15

1 Demonstration board description

The STEVAL-ISA018V1 board is based on an LLC resonant converter, and employs the 5 Ω , 500 V STF21NM50N power MOSFET as the primary switches in the half-bridge. The STF21NM50N is produced using STMicroelectronics' proprietary high voltage MDmesh™ II technology. Thanks to this technology, the switch features a very low $R_{DS(on)}$ per area, low gate charge and high switching performance. The device is available in different packages, i.e. the TO-220, TO-247 and TO-220FH.

The demonstration board has been designed based on the specifications listed in [Table 1](#).

Table 1. Main specifications

Parameter	Value
Input voltage range	a. 185 to 265 Vac - b. 85 to 185 Vac (with voltage double)
Input frequency range	50/60 Hz
Output voltage	24 V \pm 2%
Output power	150 W (240Wpk)
Safety	EN60950
EMI	EN55014

The electrical schematic of the board is shown in [Figure 2](#). The input section is provided with a connector for line input and a jumper for voltage double operation for a 110 Vac input voltage.

The output voltage is available on the CN3 connector. The converter is controlled by the L6599, a double ended primary controller for resonant half-bridge ZVS (zero voltage switching). The IC controls the output power, changing the switching frequency and controlling the half-bridge with a constant 50% duty cycle by means of a dedicated pin, connected to the output feedback through an optocoupler. Light load conditions are managed, with optimized consumption, thanks to burst mode operation. The IC also includes a disable function and two-level over-current protection with programmable delay.

In order to properly run the half-bridge devices and guarantee high efficiency, the IC features an internal P- channel D-MOS transistor with a typical $R_{DS(on)}$ of 200 m Ω as a switching element to avoid the use of a bootstrap capacitor.

During normal operation the IC is powered by the auxiliary winding of the transformer via the D9 diode. A discrete linear voltage regulator is connected in order to stabilize the auxiliary voltage fluctuations. The circuit consists of Q4, C42, R38, D3, D12, C32 and C33.

Figure 2. Schematic

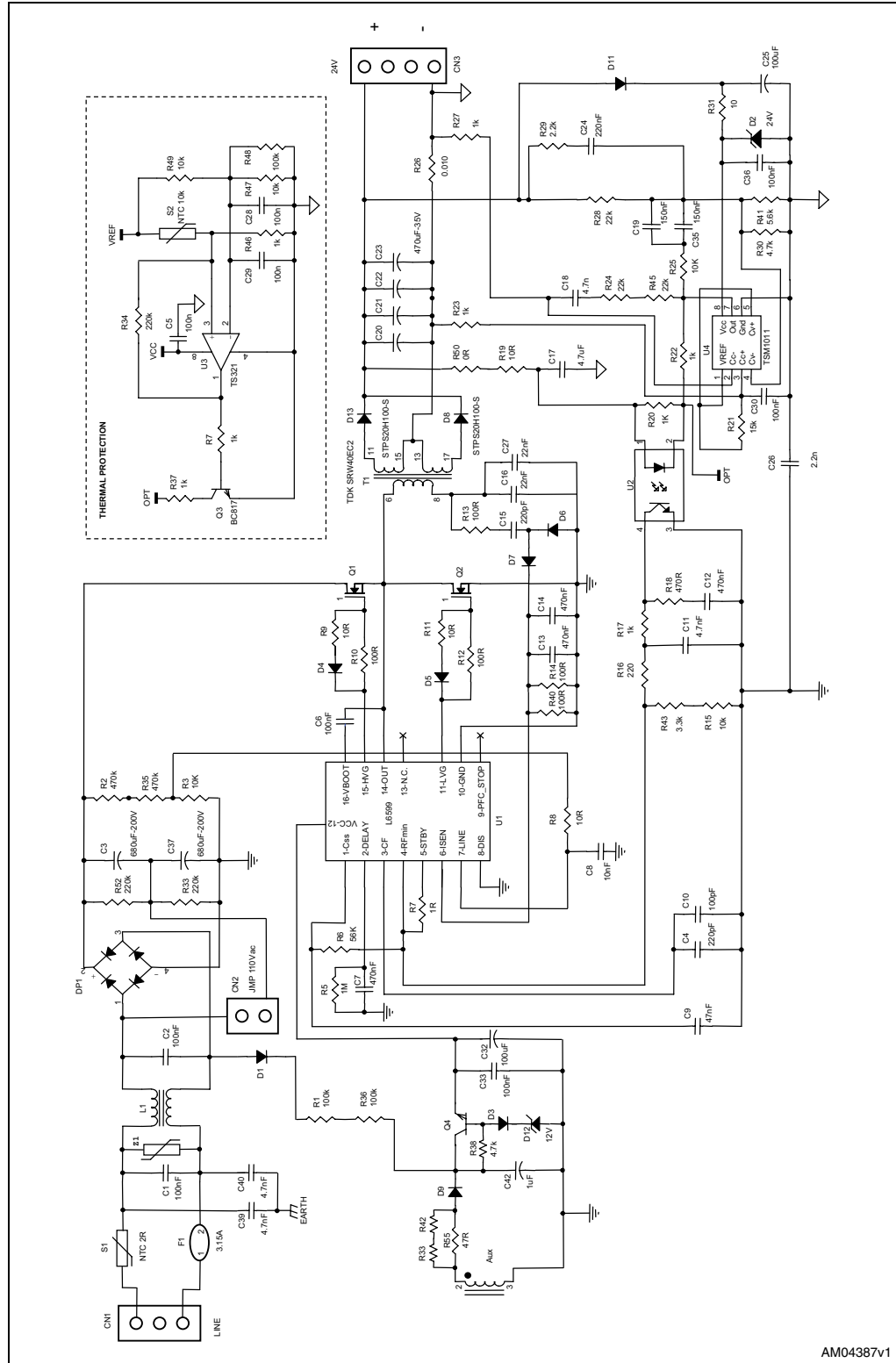

Regulation of the output voltage is performed by secondary feedback on the 24 V output. The feedback network consists of a programmable voltage reference, TSM1011, driving an optocoupler which ensures the required insulation between the primary and secondary sections. The optotransistor drives the feedback pin (RFMIN) which controls the operation of the IC.

The resonant transformer is based on a two-slot coil former and an EER39-PC40 ferrite core, manufactured by TDK. The transformer ensures safety insulation in accordance with EN60950.

In [Table 2](#) the main features of the transformer are listed and in [Figure 3](#) and [4](#) the pinout and the geometrical characteristics are shown respectively.

Table 2. Resonant transformer specifications

Parameter	Value
Core	EER39 – PC40
Coil former	2 slot
Primary inductance, Lp	450 μ H \pm 10%
Leakage inductance, Llk	150 μ H \pm 10%
Primary turns, Np	32 (0.15x20) – 220 m Ω (DC)
Secondary turns, Ns	2x7 (0.2x30) (bifilar) – 40 m Ω (DC)
Auxiliary turns, Naux	8 (on primary winding)

Figure 3. Resonant transformer: pinout

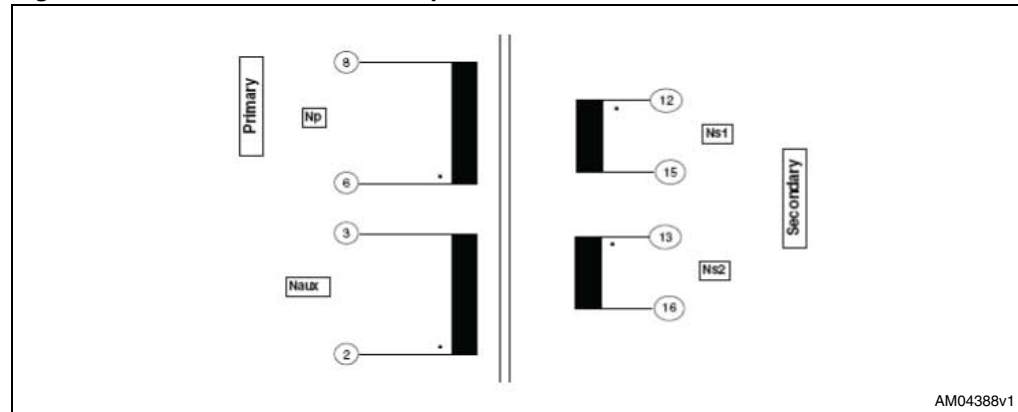

AM04388v1

Figure 4. Resonant transformer: mechanical drawing

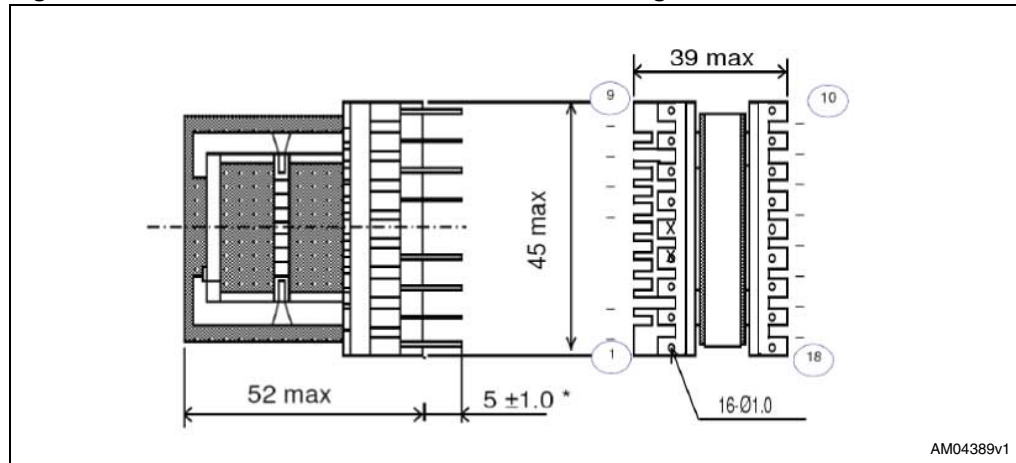

The output voltage can be adjusted down to 1.235 V by a voltage divider. An internal oscillator fixes the switching frequency up to 500 kHz to minimize the size of external components. The power IC features several layers of protection, such as pulse by pulse current limit with internal frequency modulation aimed at an effective constant current short circuit protection, feedback disconnection and thermal shutdown. Finally, it can be synchronized using a dedicated pin as well as inhibited for reduced standby power consumption and time sequence operations.

The board layout is shown in [Figure 5](#). The whole power supply is produced on a double side 35 μm PCB FR-4 (130 x 66 mm).

Figure 5. STEVAL-ISA018V1 board layout with tracks

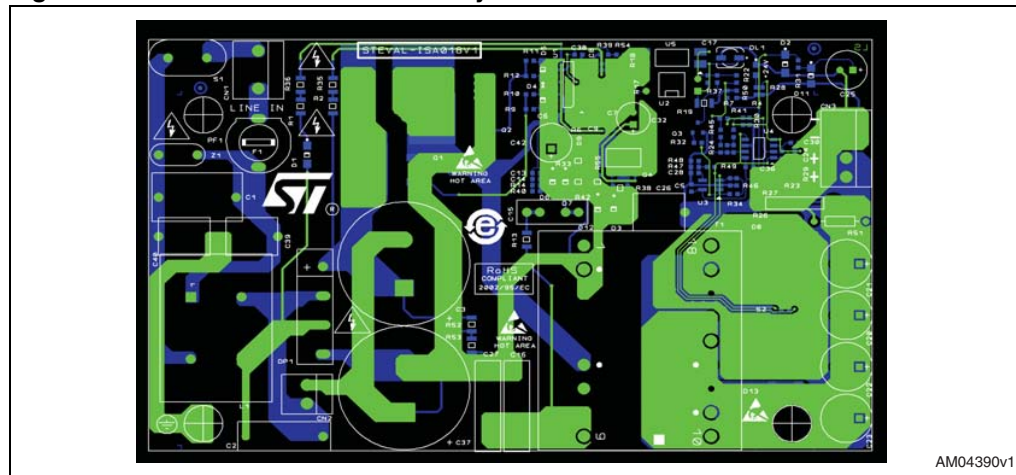

Table 3. STEVAL-ISA018V1 BOM list

Reference	Value	Description
C1	220 nF	Polyester X2 – 275 Vac
C2	100 nF	Polyester X2 – 275 Vac
C3	680 μ F	Elect. capacitor 200 V
C4	220 pF	Ceramic capacitor NPO
C5	100 nF	Ceramic capacitor Y5 V
C6	100 nF	Ceramic capacitor Y5 V
C7	4.7 nF	Ceramic capacitor Y5 V
C8	10 nF	Ceramic capacitor Z5U
C9	47 nF	Ceramic capacitor Y5 V
C10	100 pF	Ceramic capacitor NPO
C12	470 pF	Ceramic capacitor Y5 V
C14	470 pF	Ceramic capacitor Y5 V
C15	220 pF	Polip. capacitor 630 V
C16	22 nF	Ceramic capacitor 630 V
C17	4.7 μ F	Elect. capacitor
C18	47 nF	Elect. capacitor Y5 V
C19	100 nF	Ceramic capacitor Y5 V
C20	470 μ F	Elect. capacitor 35 V
C21	470 μ F	Elect. capacitor 35 V
C22	470 μ F	Elect. capacitor 35 V
C23	470 μ F	Elect. capacitor 35 V
C24	220 nF	Ceramic capacitor Y5 V
C25	100 μ F	Elect. capacitor 50 V
C26	2.2 nF	Polyester capacitor Y1 - 300 Vac
C27	22 nF	Ceramic capacitor 630 V
C28	100 nF	Ceramic capacitor Y5 V
C29	100 nF	Ceramic capacitor Y5 V
C30	100 nF	Ceramic capacitor Y5 V
C32	100 μ F	Elect. capacitor 25 V
C33	100 nF	Ceramic capacitor Y5 V
C35	47 nF	Ceramic capacitor Y5 V
C36	100 nF	Ceramic capacitor Y5 V
C37	680 μ F	Elect. capacitor 200 V
C39	4.7 nF	Ceramic capacitor Y2 – 250 Vac
C40	4.7 nF	Ceramic capacitor Y2 – 250 Vac

Table 3. STEVAL-ISA018V1 BOM list (continued)

Reference	Value	Description
C42	1 μ F	Elect. capacitor 160 V
CN1	3 pos	Connector - pitch 3.96 mm
CN2	2 pos	Connector - pitch 3.96 mm
CN3	4 pos	Connector - pitch 3.96 mm
DP1		Bridge rectifier 8 A - 600 V
D1	S1M/11T	Rectifier 1 A - 1000 V - DO214AC
D2		Zener diode 24 V - 1 W
D3	LS4148	Ultrafast diode 200 mA - 75 V - SOD80
D4	LS4148	Ultrafast diode 200 mA - 75 V - SOD80
D5	LS4148	Ultrafast diode 200 mA - 75 V - SOD80
D6	LS4148	Ultrafast diode 200 mA - 75 V - SOD80
D7	LS4148	Ultrafast diode 200 mA - 75 V - SOD80
D8	STPS20H100	STMicroelectronics - Schottky rectifier 2x10A - 100 V
D9	BAV23C	Fast rectifier 2x400 mA - 250 V - SOT23
D11	LS4148	Ultrafast diode 200 mA - 75 V - SOD80
D12		Zener diode 12 V - 1 W
D13	STPS20H100	STMicroelectronics - Schottky rectifier 2x10 A - 100 V
DL1	LED	LED red 0805
L1	2x25 mH	CM choke - TDK HF2836 - 1.2 A
NTC1	2 Ω - 4 A	NTC Inrush current suppressor
NTC2	10 k Ω	NTC -40 $^{\circ}$ C to 125 $^{\circ}$ C
F1	3.15 A	Fuse 250 V delayed
R1	100 k Ω	Resistor, 5% - SMD 1206
R2	470 k Ω	Resistor, 5% - SMD 1206
R3	10 k Ω	Resistor, 5% - SMD 0603
R4	10 k Ω	Resistor, 5% - SMD 0603
R5	1 M Ω	Resistor, 5% - SMD 0603
R6	56 k Ω	Resistor, 5% - SMD 0603
R8	10 Ω	Resistor, 5% - SMD 0603
R9	10 Ω	Resistor, 5% - SMD 0603
R10	100 Ω	Resistor, 5% - SMD 0603
R11	10 Ω	Resistor, 5% - SMD 0603
R12	100 Ω	Resistor, 5% - SMD 0603
R13	100 Ω	Resistor, 5% - SMD 1206
R14	100 Ω	Resistor, 5% - SMD 0603

Table 3. STEVAL-ISA018V1 BOM list (continued)

Reference	Value	Description
R15	10 k Ω	Resistor, 5% - SMD 0603
R16	220 Ω	Resistor, 5% - SMD 0603
R17	1 k Ω	Resistor, 5% - SMD 0603
R18	470 Ω	Resistor, 5% - SMD 0603
R19	10 Ω	Resistor, 5% - SMD 0603
R20	1 k Ω	Resistor, 5% - SMD 0603
R21	15 k Ω	Resistor, 5% - SMD 0603
R22	1 k Ω	Resistor, 5% - SMD 0603
R23	1 k Ω	Resistor, 5% - SMD 0603
R24	22 k Ω	Resistor, 5% - SMD 0603
R25	10 k Ω	Resistor, 5% - SMD 0603
R26	0.1 Ω	Shunt resistor 3 W
R27	1 k Ω	Resistor, 5% - SMD 0603
R28	22 k Ω	Resistor, 1% - SMD 0603
R29	2.2 k Ω	Resistor, 5% - SMD 0603
R30	4.7 k Ω	Resistor, 5% - SMD 0603
R31	10 Ω	Resistor, 5% - SMD 0603
R32	1 k Ω	Resistor, 5% - SMD 0603
R34	220 k Ω	Resistor, 5% - SMD 0603
R35	470 k Ω	Resistor, 5% - SMD 1206
R36	100 k Ω	Resistor, 5% - SMD 1206
R37	1 k Ω	Resistor, 5% - SMD 0603
R38	4.7 k Ω	Resistor, 5% - SMD 1206
R40	100 Ω	Resistor, 5% - SMD 0603
R41	5.6 k Ω	Resistor, 1% - SMD 0603
R43	3.3 k Ω	Resistor, 5% - SMD 0603
R45	22 k Ω	Resistor, 5% - SMD 0603
R46	1 k Ω	Resistor, 5% - SMD 0603
R47	10 k Ω	Resistor, 5% - SMD 0603
R48	100 k Ω	Resistor, 5% - SMD 0603
R49	10 k Ω	Resistor, 5% - SMD 0603
R50	0 Ω	Resistor, - SMD 0603
R51	1 k Ω	Resistor, 5% - 1W
R52	220 k Ω	Resistor, 5% - SMD 1206
R53	220 k Ω	Resistor, 5% - SMD 1206

Table 3. STEVAL-ISA018V1 BOM list (continued)

Reference	Value	Description
R54	0 Ω	Resistor, - SMD 0603
R55	47 Ω	Resistor, 5% - SMD 1206
T1	SRW40EC2-E01	Switch mode transformer - TDK
U1	L6599	STMicroelectronics - high voltage resonant controller
U2	TCET1101	Optocoupler - Vishay
U3	TS321	STMicroelectronics - low power single operational amplifier - SOT 23-5
U4	TSM1011	STMicroelectronics constant voltage and constant current controller - SO-8
Q1	STB21NM50N	STMicroelectronics - MOSFET MDmesh II 500 V -0.15 Ω - 18 A - D ² PAK
Q2	STB21NM50N	STMicroelectronics - MOSFET MDmesh II 500 V -0.15 Ω - 18 A - D ² PAK
Q3	BC817	STMicroelectronics - small signal NPN transistor 50 V - 1 A SOT-23
Q4	STN715	STMicroelectronics - NPN medium power transistor 140 V - 1 A SOT-223
Z1	VK300	Varistor 300 V

2 Experimental waveforms

In this section some experimental waveforms are given. The contents of the following images show the output ripple, both at low frequency and high frequency, the short circuit protection operations and the startup and shutdown waveforms.

Figure 6. Midpoint voltage and transformer current - $V_{in} = 230\text{ Vac}$, $V_{out}=24.6\text{ V}$, $I_{out} = 2\text{ A}$ (CH1: HB midpoint voltage; CH2: transformer current)

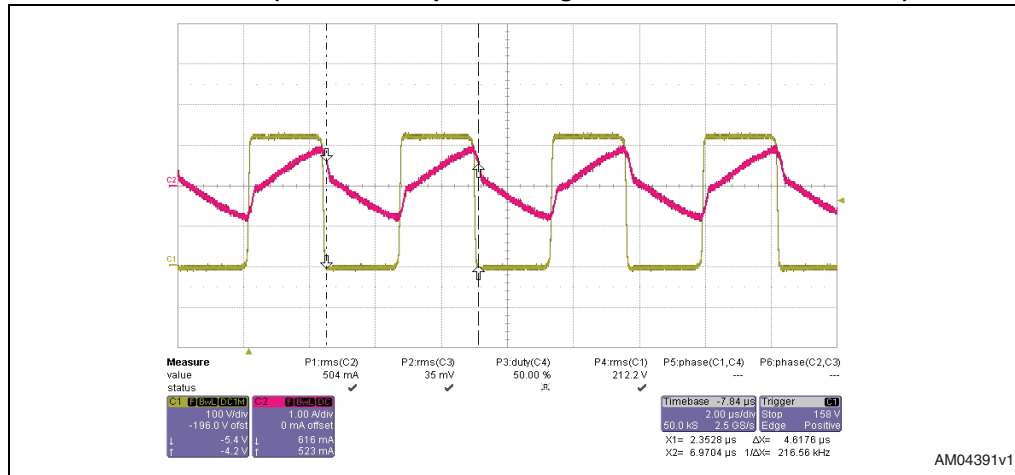

Figure 7. Midpoint voltage and transformer current - $V_{in} = 230\text{ Vac}$, $V_{out}=24.6\text{ V}$, $I_{out} = 2\text{ A}$ (CH1: HB midpoint voltage; CH2: transformer current)

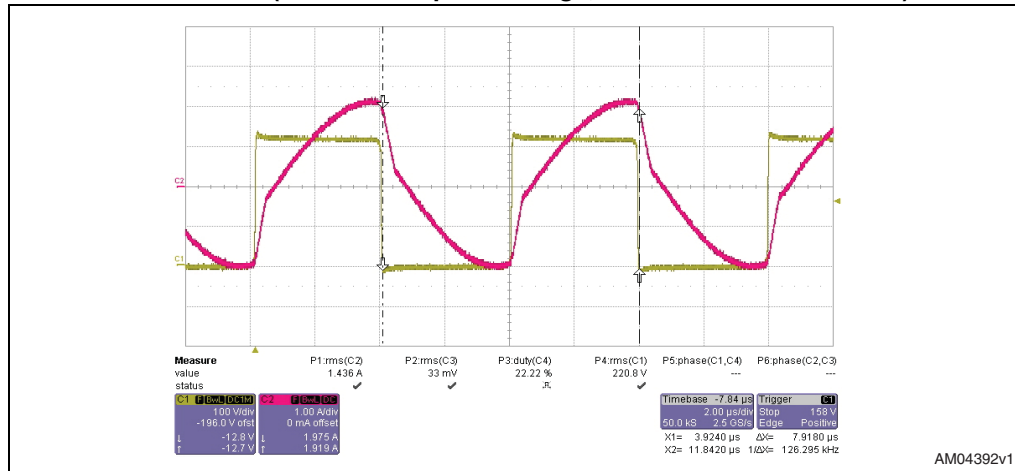

Figure 8. Midpoint voltage and transformer current - $V_{in} = 230\text{ Vac}$, $V_{out}=24.6\text{ V}$, $I_{out} = 2\text{ A}$ (CH1: HB midpoint voltage; CH2: transformer current)

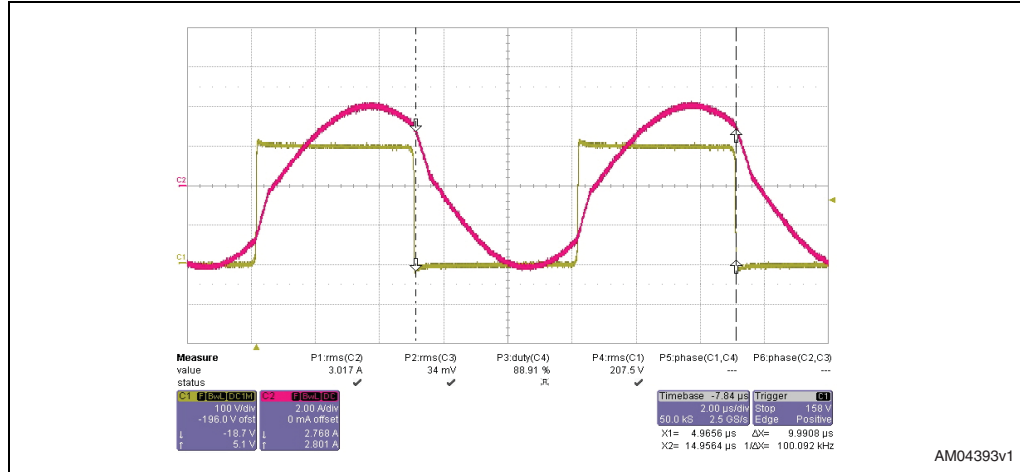

Figure 9. Midpoint voltage and transformer current - $V_{in} = 230\text{ Vac}$, $V_{out}=24.6\text{ V}$, $I_{out} = 2\text{ A}$ (CH1: HB midpoint voltage; CH2: transformer current)

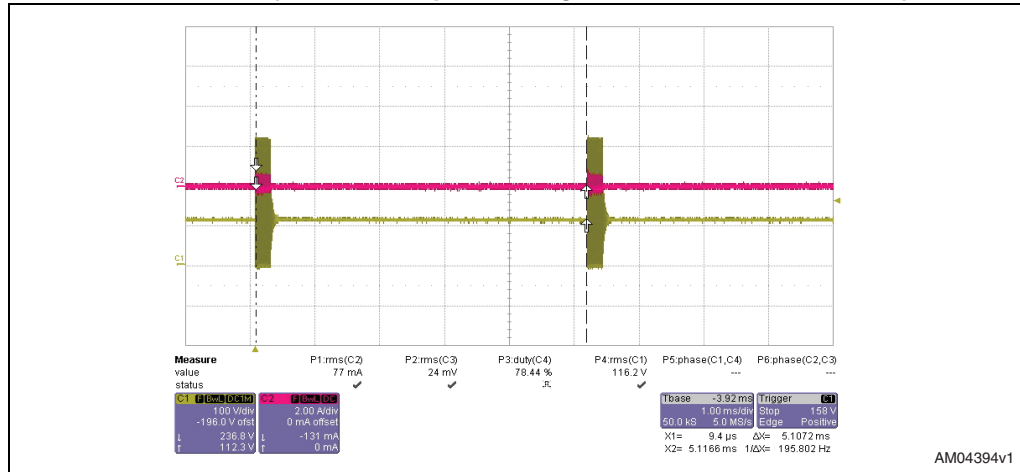
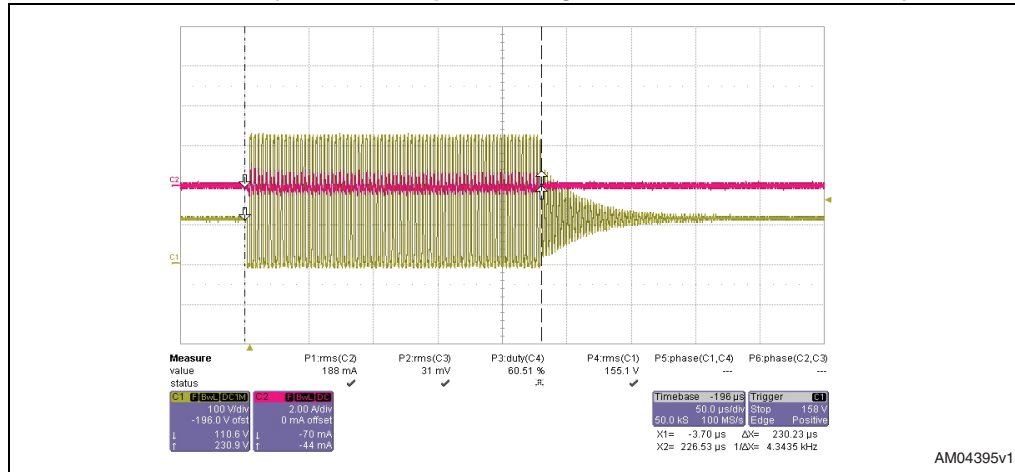

Figure 10. Midpoint voltage and transformer current - $V_{in} = 230 \text{ Vac}$, $V_{out} = 24.6 \text{ V}$, $I_{out} = 2 \text{ A}$ (CH1: HB midpoint voltage; CH2: transformer current)



3 EMI measurements

EMI behavior has been evaluated, as shown in [Figure 11](#) and [12](#), and measurements have been obtained using the standard settings with a $50\ \Omega$ LISN and a spectrum analyzer using the peak detector. The emissions are below the limit of the quasi-peak mask although the peak detector has been used, confirming the suitability of the topology with “light” EMI filters.

Figure 11. Conducted emissions - phase - $V_{in} = 230\ \text{Vac}$, $I_{out} = 6\ \text{A}$

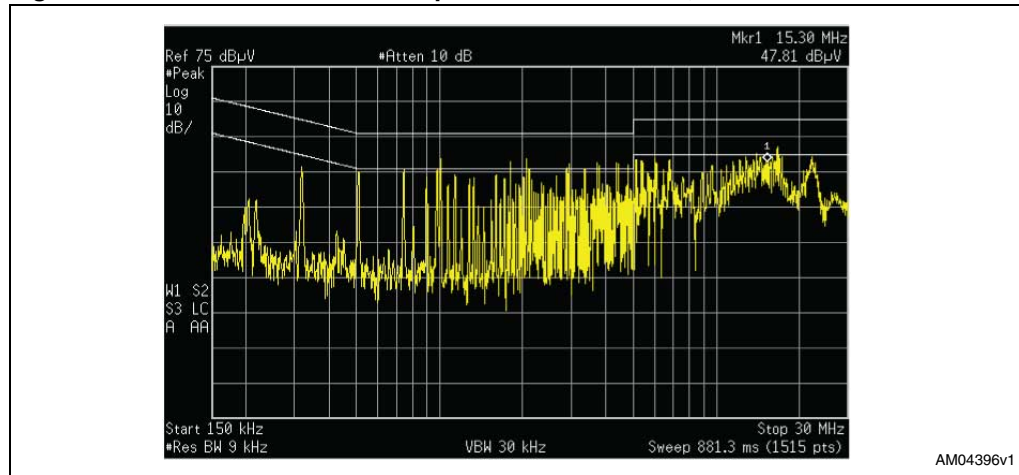
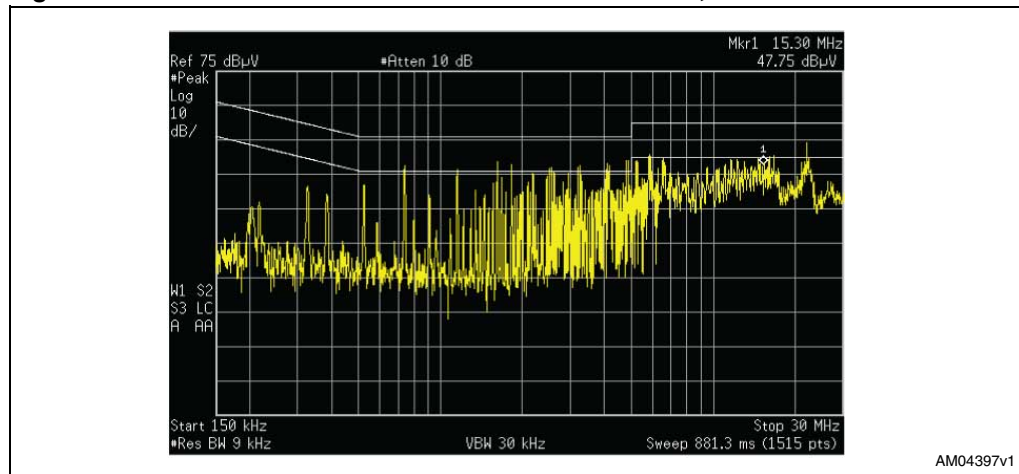

Figure 12. Conducted emissions - neutral - $V_{in} = 230\ \text{Vac}$, $I_{out} = 6\ \text{A}$



4 Conclusions

This document describes the STEVAL-ISA018V1 demonstration board which implements a single output SMPS for industrial applications. The power supply is based on the L6599 resonant controller and uses the latest MDmesh II power MOSFET technology in order to achieve very high efficiency in all the operating range.

5 Revision history

Table 4. Document revision history

Date	Revision	Changes
18-May-2010	1	Initial release

Please Read Carefully:

Information in this document is provided solely in connection with ST products. STMicroelectronics NV and its subsidiaries ("ST") reserve the right to make changes, corrections, modifications or improvements, to this document, and the products and services described herein at any time, without notice.

All ST products are sold pursuant to ST's terms and conditions of sale.

Purchasers are solely responsible for the choice, selection and use of the ST products and services described herein, and ST assumes no liability whatsoever relating to the choice, selection or use of the ST products and services described herein.

No license, express or implied, by estoppel or otherwise, to any intellectual property rights is granted under this document. If any part of this document refers to any third party products or services it shall not be deemed a license grant by ST for the use of such third party products or services, or any intellectual property contained therein or considered as a warranty covering the use in any manner whatsoever of such third party products or services or any intellectual property contained therein.

UNLESS OTHERWISE SET FORTH IN ST'S TERMS AND CONDITIONS OF SALE ST DISCLAIMS ANY EXPRESS OR IMPLIED WARRANTY WITH RESPECT TO THE USE AND/OR SALE OF ST PRODUCTS INCLUDING WITHOUT LIMITATION IMPLIED WARRANTIES OF MERCHANTABILITY, FITNESS FOR A PARTICULAR PURPOSE (AND THEIR EQUIVALENTS UNDER THE LAWS OF ANY JURISDICTION), OR INFRINGEMENT OF ANY PATENT, COPYRIGHT OR OTHER INTELLECTUAL PROPERTY RIGHT.

UNLESS EXPRESSLY APPROVED IN WRITING BY AN AUTHORIZED ST REPRESENTATIVE, ST PRODUCTS ARE NOT RECOMMENDED, AUTHORIZED OR WARRANTED FOR USE IN MILITARY, AIR CRAFT, SPACE, LIFE SAVING, OR LIFE SUSTAINING APPLICATIONS, NOR IN PRODUCTS OR SYSTEMS WHERE FAILURE OR MALFUNCTION MAY RESULT IN PERSONAL INJURY, DEATH, OR SEVERE PROPERTY OR ENVIRONMENTAL DAMAGE. ST PRODUCTS WHICH ARE NOT SPECIFIED AS "AUTOMOTIVE GRADE" MAY ONLY BE USED IN AUTOMOTIVE APPLICATIONS AT USER'S OWN RISK.

Resale of ST products with provisions different from the statements and/or technical features set forth in this document shall immediately void any warranty granted by ST for the ST product or service described herein and shall not create or extend in any manner whatsoever, any liability of ST.

ST and the ST logo are trademarks or registered trademarks of ST in various countries.

Information in this document supersedes and replaces all information previously supplied.

The ST logo is a registered trademark of STMicroelectronics. All other names are the property of their respective owners.

© 2010 STMicroelectronics - All rights reserved

STMicroelectronics group of companies

Australia - Belgium - Brazil - Canada - China - Czech Republic - Finland - France - Germany - Hong Kong - India - Israel - Italy - Japan - Malaysia - Malta - Morocco - Philippines - Singapore - Spain - Sweden - Switzerland - United Kingdom - United States of America

www.st.com