



# MAX4754A Evaluation Kit

Evaluates: MAX4754A

## General Description

The MAX4754A evaluation kit (EV kit) is a fully assembled and tested printed-circuit board (PCB) that demonstrates the capabilities of the MAX4754A 0.5Ω, quad single-pole, double-throw (SPDT) switch with dual control lines. The EV kit comes with the MAX4754AETE+ installed.

## Features

- ◆ Data and Audio Signal Routing
- ◆ Low RON (0.5Ω typ) Audio Switches
- ◆ +1.8V to +5.5V Supply Range
- ◆ Proven PCB Layout
- ◆ Fully Assembled and Tested

## Ordering Information

PART	TYPE	IC PACKAGE
MAX4754AEVKIT+	EV kit	16 Thin QFN-EP* (4mm x 4mm)

+ Denotes a lead-free and RoHS-compliant EV kit.

\*EP = Exposed paddle.

## Component List

DESIGNATION	QTY	DESCRIPTION
C1	1	0.1μF ±15%, 25V X7R ceramic capacitor (0603) TDK C1608X7R1E104K
C2	1	10μF ±10%, 10V X5R ceramic capacitor (0805) TDK C2012X5R1A106K
JU1, JU2	2	2-pin headers
R1, R2	2	100kΩ ±5% resistors (0603)
U1	1	MAX4754AETE+ (16-pin thin QFN, 4mm x 4mm)
—	1	PCB: MAX4754A Evaluation Kit+

## Component Supplier

SUPPLIER	PHONE	WEBSITE
TDK Corp.	847-803-6100	www.component.tdk.com

**Note:** Indicate that you are using the MAX4754A when contacting this component supplier.

# MAX4754A Evaluation Kit

## Quick Start

### Recommended Equipment

- One +5V DC power supply
- One ohmmeter

### Procedure

The MAX4754A EV kit is fully assembled and tested. Follow the steps below to verify board operation. **Caution: Do not turn on the power supply until all connections are completed.**

- 1) Turn off the 5V DC power supply.
- 2) Make sure the shunts of all jumpers are in the following default positions:
 

JU1: (1-2)	INA is high
JU2: (1-2)	INB is high
- 3) Connect the (-) terminal of the 5V DC power supply to any GND pad of the MAX4754A EV kit. Connect the (+) terminal to the VDD pad.
- 4) Connect one terminal of the ohmmeter to the COM1 pad of the MAX4754A EV kit. Connect the other terminal of the ohmmeter to the NC1 pad.
- 5) Turn on the 5V DC power supply.
- 6) Remove the shunt of jumper JU1, then put it back on; observe the display difference of the ohmmeter during the jumper changing

**Table 1. Jumper JU1 Configuration**

JUMPER	SHUNT POSITION	DESCRIPTION
JU1	1-2*	INA is logic-high
	Open	INA is logic-low

\*Default position.

## Detailed Description of Hardware

The MAX4754A is a 0.5Ω, quad SPDT switch with dual control lines. The MAX4754A EV kit board provides a proven layout for evaluating the MAX4754A. The EV kit comes with a MAX4754AETE+ installed.

### Switch Control

There are two jumpers (JU1 and JU2) on the MAX4754A EV kit board, which individually control the logic level of the digital control inputs INA and INB, as shown in Tables 1 and 2. Refer to the MAX4754A data sheet for a detailed description of the switching function.

### Power Supply

The MAX4754A EV kit is powered from a user-supplied +1.8V to +5.5V DC power supply connected to the VDD and GND pads.

**Table 2. Jumper JU2 Configuration**

JUMPER	SHUNT POSITION	DESCRIPTION
JU2	1-2*	INB is logic-high
	Open	INB is logic-low

\*Default position.

# MAX4754A Evaluation Kit

Evaluates: MAX4754A

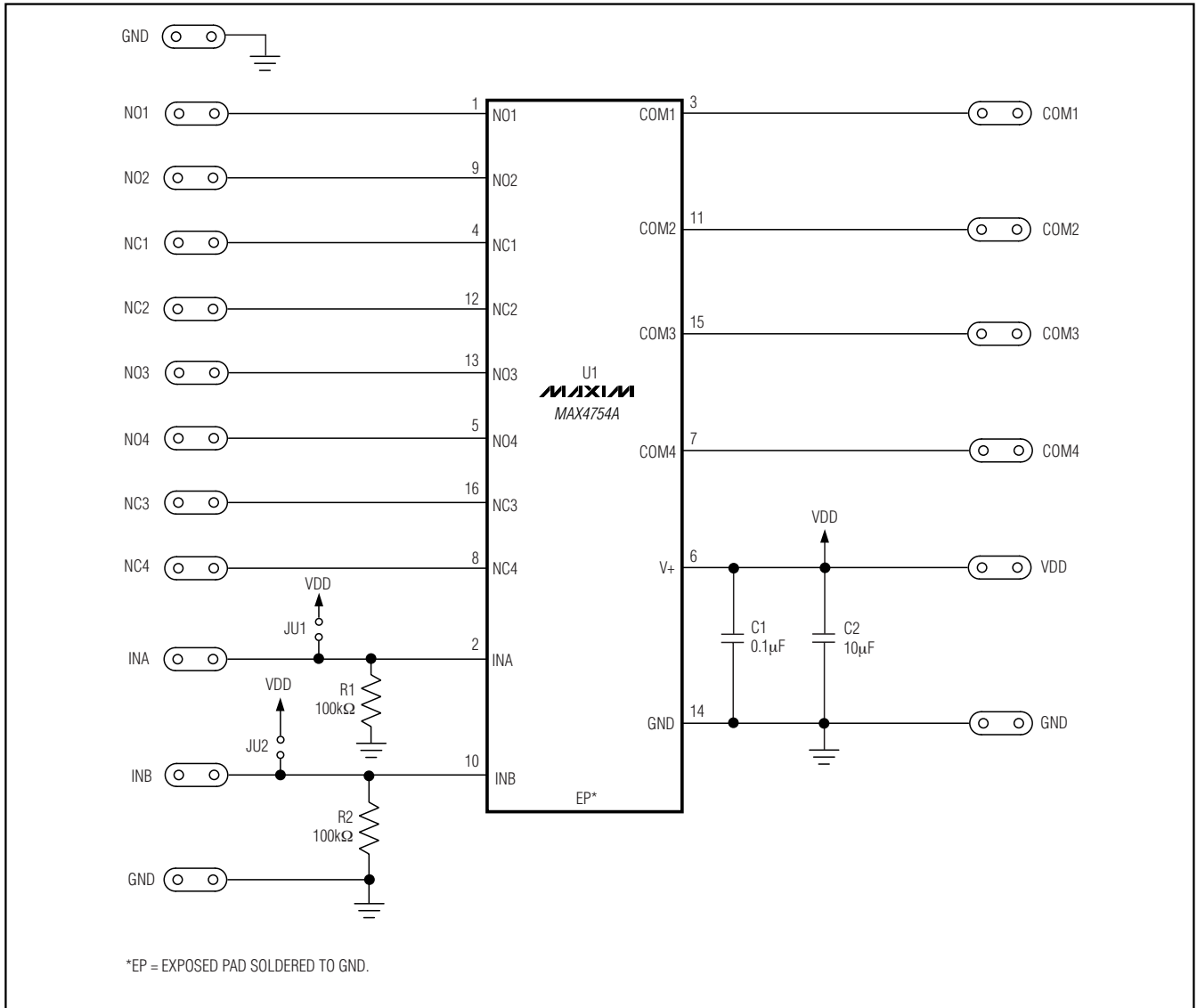

Figure 1. MAX4754A EV Kit Schematic

# MAX4754A Evaluation Kit

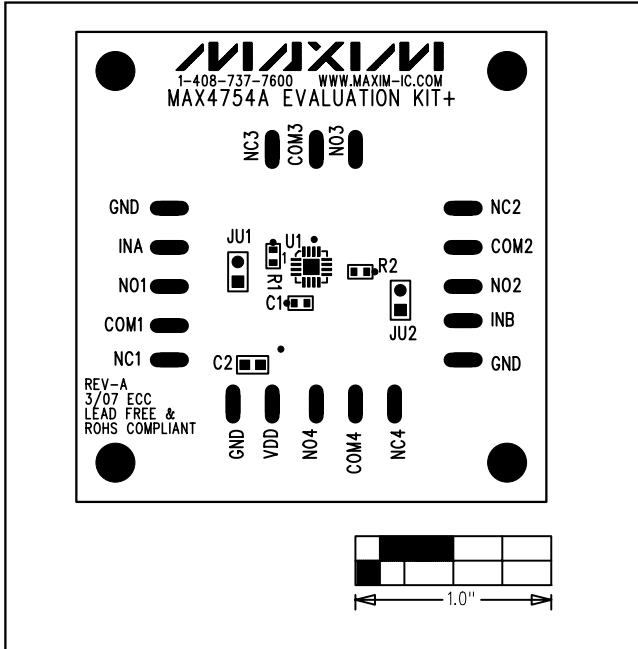

Figure 2. MAX4754A EV Kit Component Placement Guide—Component Side

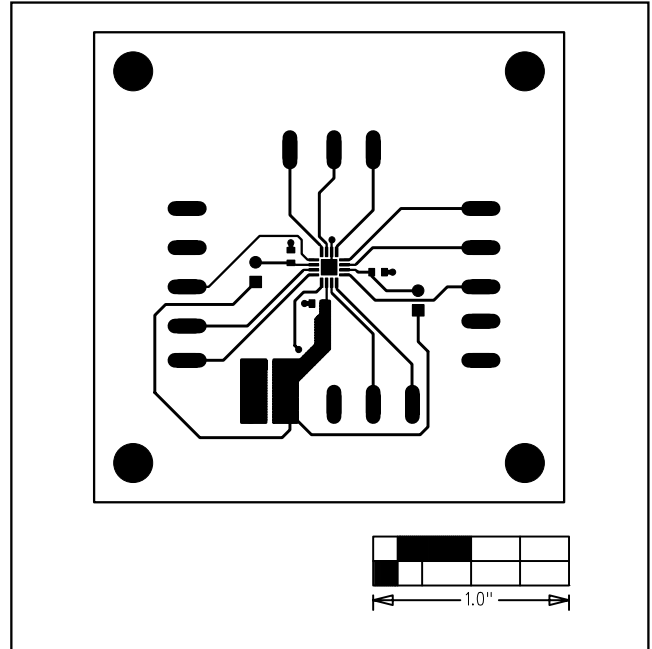

Figure 3. MAX4754A EV Kit PCB Layout—Component Side

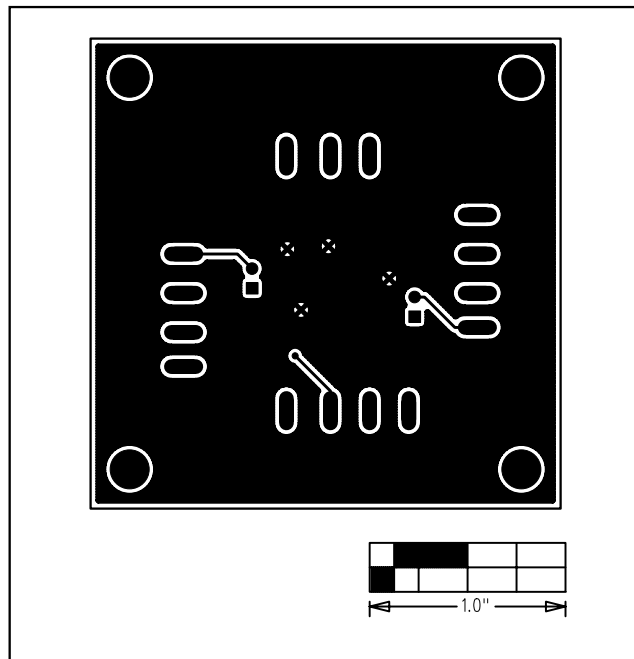

Figure 4. MAX4754A EV Kit PCB Layout—Solder Side

Maxim cannot assume responsibility for use of any circuitry other than circuitry entirely embodied in a Maxim product. No circuit patent licenses are implied. Maxim reserves the right to change the circuitry and specifications without notice at any time.

4 \_\_\_\_\_ **Maxim Integrated Products, 120 San Gabriel Drive, Sunnyvale, CA 94086 408-737-7600**

© 2007 Maxim Integrated Products

**MAXIM** is a registered trademark of Maxim Integrated Products, Inc.