

# LMH1982 Evaluation Board User Guide

National Semiconductor  
Application Note 1841  
May 21, 2008



## Table of Contents

1.0 LMH1982 Evaluation Board .....	2
1.1 USB INTERFACE BOARD .....	2
1.2 POWER SUPPLIES .....	2
1.3 REFERENCE PORTS .....	3
1.3.1 Analog Reference Input .....	3
1.3.2 Digital Reference Input .....	3
1.4 OUTPUT CLOCKS .....	3
1.5 OUTPUT TOP OF FRAME .....	3
1.6 27 MHZ VCXO AND LOOP FILTER .....	3
1.6.1 VCXO Power Supply Considerations .....	4
1.7 FREE RUN CONTROL VOLTAGE INPUT .....	4
1.8 CONTROL INPUTS .....	4
1.9 GENLOCK STATUS INDICATION .....	4
1.10 I <sup>2</sup> C INTERFACE .....	5
1.11 USB BOARD AND PC SOFTWARE APPLICATION .....	5
1.12 LIST OF TEST POINTS .....	5
2.0 Evaluation Board Schematic .....	5
3.0 Evaluation Board Layout .....	8
4.0 Evaluation Board Bill of Materials .....	9
5.0 References .....	10

## List of Figures

FIGURE 1. ....	2
FIGURE 2. ....	4
FIGURE 3. ....	5
FIGURE 4. ....	6
FIGURE 5. ....	6
FIGURE 6. ....	7
FIGURE 7. ....	8
FIGURE 8. ....	8

## List of Tables

TABLE.1 .....	2
TABLE.2 .....	2
TABLE.3 .....	3
TABLE.4 .....	3
TABLE.5 .....	3
TABLE.6 .....	4
TABLE.7 .....	4
TABLE.8 .....	4
TABLE.9 .....	5

## 1.0 LMH1982 Evaluation Board

The LMH1982 evaluation board was designed by National Semiconductor (NSC) to evaluate the performance and operation of the LMH1982 multi-rate video clock and timing generator with the LMH1981 SD/HD video sync separator. The evaluation board provides input ports to receive analog or digital reference signals, SMA connector ports to transmit the differential output clocks, and headers to access various input/output signals. On-board toggle switches allow control over the sync inputs and control inputs, such as device reset. A USB interface board is also provided to allow programming of the LMH1982 through a PC's USB port using NSC's LMH1982 evaluation software.

Refer to the Evaluation Board Schematic, PCB Layout, and Bill of Materials sections, as well as the collateral listed in the References section.

### 1.1 USB INTERFACE BOARD

Headers X2 and X4 of the USB interface board should be plugged into headers J7 and J11 of the evaluation board. The USB board's firmware supports the I<sup>2</sup>C interface, which enables the user to program the LMH1982 from a PC running the evaluation software. The USB board can also provide 5V from the PC's USB port to power the LDO regulators on the evaluation board. The block diagram in *Figure 1* shows the connections between the PC, USB board, and evaluation board.

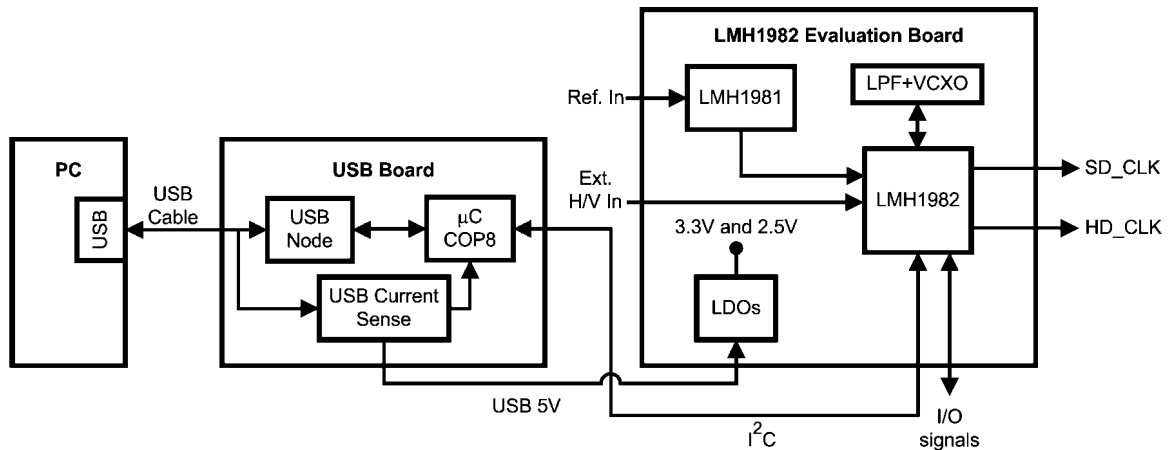

30061909

FIGURE 1. Simplified Block Diagram of the Evaluation Setup

### 1.2 POWER SUPPLIES

The evaluation board requires a 5V supply and ground connection to power the on-board LP38693 LDO regulators (U1, U2).

To use 5V from the USB port via header J7, shunt pins 1 and 2 of jumper JP3. Refer to *Table 1* for the pin assignment of JP3. If the USB supply is used, make sure that the USB port of the PC is capable of nominally sourcing 150 mA (0.75W at 5V). When powering the evaluation board, the USB supply voltage should measure  $5V \pm 5\%$  at pin 4 of J7.

To use an external 5V supply, shunt pins 2 and 3 of JP3 and connect the supply leads to pins 1 and 2 of header J1.

TABLE 1. 5V Select Jumper, JP3

Pin #, Location	Pin Name
1, Left	EXT 5V
2, Center	INPUT 5V
3, Right	USB 5V

The LP38693 LDO regulators provide clean 3.3V and 2.5V for the evaluation board. If needed, it is possible to bypass the LDOs and apply external 3.3V and 2.5V supplies to the appropriate pins of J1. See *Table 2* for the pin assignments of J1. Before applying an external 3.3V supply, remove R2 and short JP1. Similarly, before applying an external 2.5V supply,

remove R4 and short JP2. If external supplies are used, it is recommended to keep the supply noise to within the same levels offered by the on-board LDO regulators. Refer to the LP38693 datasheet for more information.

TABLE 2. External Power Header, J1

Pin #, Location	Pin Name
1, Left-most	EXT 5V
2	GND
3	EXT 3V3
4	GND
5	EXT 2V5
6, Right-most	GND

The LMH1982 requires that 3.3V and 2.5V are regulated to within  $\pm 5\%$  and have low noise to ensure optimal output jitter performance. The 27 MHz VCXO also requires a clean 3.3V supply and proper supply bypassing for optimal performance.

The DVDD (2.5V) and VDD (3.3V) supply voltages of the LMH1982 can be measured at test points TP1 and TP3, respectively. DVDD and VDD supply currents can also be measured by removing the  $0\Omega$  resistors from R22 and R3 and then using a current meter in series.

### 1.3 REFERENCE PORTS

The LMH1982 has two reference ports (REF\_A and REF\_B) with H sync and V sync inputs, which are used for phase locking the outputs in Genlock mode. The input signals can be measured at test points TP27, TP28, TP30, and TP31.

#### 1.3.1 Analog Reference Input

An SD or HD analog video signal can be applied to the BNC connector (J2) to extract H and V sync signals using the LMH1981 (U4) or LMH1980 (U3) video sync separator. The board is originally populated with the LMH1981, while the option for LMH1980 is not populated (NP) since the sync separators share common application circuitry. A shunt can be placed on jumper JP4 to enable the low-pass chroma filter, formed by R24 and C39, to attenuate the subcarrier signal on a composite video input.

The LMH1981 supports any SMPTE-standard SD and HD analog video input with automatic format detection and outputs a low-jitter H sync signal using 50% sync slicing. The LMH1980 can also support any SD/HD standards with automatic format detection, but instead uses a fixed-level sync slicing. Refer to the LMH1981 and LMH1980 datasheets for more information.

The sync separator's output H and V sync signals can be passed to port REF\_A of the LMH1982 through the NC7WZ125 (U7) logic buffer. See *Table 3* for the toggle switch definition for SW2, which controls the operation of the U7 buffer.

**TABLE 3. Input Select Switch, SW2**

ON	OFF
— U7 buffer output is in Hi-Z mode	— U7 buffer output is enabled
— LMH1981 sync signals is gated off from port REF_A	— LMH1981 sync signals are passed to port REF_A
— External input signals can be applied to HIN_A and VIN_A of header J8	

#### 1.3.2 Digital Reference Input

In addition to the analog timing signals from the sync separator, external H and V sync input signals can be applied to ports REF\_A or REF\_B via header J8. See *Table 4* for the pin assignment of J8. **Note:** Before applying external signals to HIN\_A and VIN\_A, set SW2 = ON to avoid signal conflict with the LMH1981.

The external reference can have digital timing, such as from an SDI receiver or deserializer, and should be a recognized timing format listed in *Table 3* of the LMH1982 datasheet. A 48 kHz audio clock can also be applied to the H sync input to synchronize the output clocks.

**Note:** The H input frequency accuracy should be within the absolute pull range (APR) of the 27 MHz VCXO (e.g.  $\pm 50$  ppm) in order to phase lock the outputs to the input reference; otherwise, phase lock may not be achieved.

**TABLE 4. Input Header, J8**

Pin #	Pin Name	Pin #	Pin Name
1	GND	8	HIN_A
2	GND	7	VIN_A
3	GND	6	HIN_B
4	GND	5	VIN_B

### 1.4 OUTPUT CLOCKS

The LVDS output SD and HD clocks from the LMH1982 are routed via controlled 100 $\Omega$  differential impedance lines to edge-mount SMA connectors as indicated in *Table 5*. If a differential probe will be used to measure the clocks directly on the board, then the differential lines should be terminated by populating R37 and R38 with 100 $\Omega$ . If the SMA connectors will be used to transmit the clock signal, these resistors should not be populated; and termination should be done at the receiver instead.

To provide compatibility between various differential signaling levels and receivers, the board allows for AC coupling capacitors C31/C34 and C35/C37 on the SD\_CLK and HD\_CLK differential pairs. AC coupling allows for common-mode level translation/shifting at the receiver.

**TABLE 5. LVDS Output Clock Ports, J3 – J6**

LVDS SMA Port	Clock Port Name
J3 / J4	SD_CLK / $\overline{\text{SD\_CLK}}$
J5 / J6	HD_CLK / $\overline{\text{HD\_CLK}}$

### 1.5 OUTPUT TOP OF FRAME

The output top of frame (TOF) pulse from the LMH1982 can be measured at test point TP23 and at header J10 located at the bottom edge of the board. The TOF output is a 3.3V LVC-MOS signal. The total load capacitance on the TOF output should be less than 15 pF.

### 1.6 27 MHZ VCXO AND LOOP FILTER

The LMH1982 requires an external 27 MHz VCXO (X1) and loop filter circuitry for operation of the VCXO PLL. The board is populated with a CTS 357-series 27.0000 MHz VCXO with  $\pm 50$  ppm absolute pull range (APR), which yields 1000 Hz/V nominal tuning sensitivity ( $K_{\text{VCXO}}$ ). The VCXO input control voltage can be measured at test point TP21.

The second-order loop filter consists of  $R_S = 20$  k $\Omega$  (R8),  $C_S = 44$   $\mu$ F (C10 = C27 = 22  $\mu$ F), and  $C_P = 1$   $\mu$ F (C28). The parallel combination of C10 and C27 form the series capacitor,  $C_S$ . Based on the loop response equations provided in the LMH1982 datasheet, this loop filter yields a nominal -3 dB loop bandwidth (BW) of about 3 Hz and nominal damping factor of 0.8 assuming  $K_{\text{VCXO}} = 1000$  Hz/V,  $I_{\text{CP1}} = 250$   $\mu$ A (charge pump current for PLL 1), and  $\text{FB\_DIV} = 1716$  (feedback divider for NTSC input). This loop filter was chosen to give good output jitter performance when the LMH1982 is genlocked to a clean black burst or tri-level sync reference, such as from a Tektronix TG700 video generator.

It is possible to use different loop filter component values (or topologies) to meet output clock jitter and lock time requirements for other input reference signals and applications. For example, to generate low-jitter output clock from a high-jitter input reference (e.g. recovered H signal from an FPGA SDI receiver), a narrowband loop filter (e.g. BW < 1 Hz) is recommended for maximum jitter attenuation. In addition to changing the loop filter components,  $I_{\text{CP1}}$  can also be programmed to adjust the loop bandwidth. Refer to the LMH1982 datasheet for more complete descriptions about designing the loop filter and optimizing the VCXO PLL loop response.

The PCB layout of the external VCXO PLL circuitry is shown in .

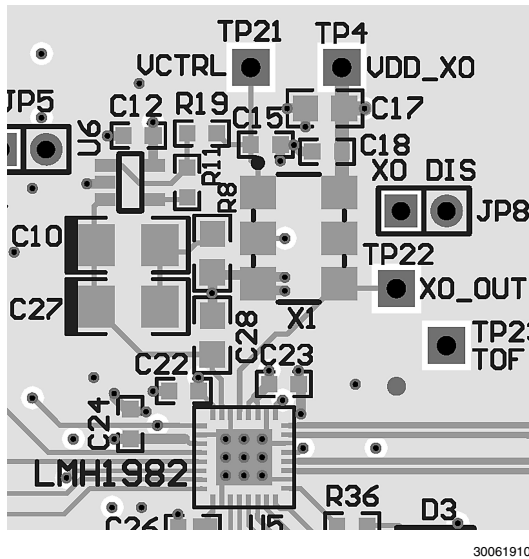

FIGURE 2. PCB Layout showing Loop Filter and VCXO

1.6.1 VCXO Power Supply Considerations

The VCXO and LMP7701 devices operate from a separate supply plane (VDD\_VCXO) derived from the board's 3.3V supply. Resistor R5 is used to form a low-pass filter with the associated decoupling and bypass capacitors to attenuate supply noise to these devices. Refer to the VCXO power supply and ground routing in the PCB layout section.

1.7 FREE RUN CONTROL VOLTAGE INPUT

The LMH1982 provides the option to set the VCXO's free run control voltage by external biasing of the VC\_FREERUN input (pin 1). The analog bias voltage applied to the VC\_FREERUN input will be internally connected to the LPF output (pin 31) though a low impedance switch when the LMH1982 is operating in free run. The resultant voltage at the LPF output will drive the VCXO control input to set the free run output frequency accuracy of the VCXO and LMH1982. The VC\_FREERUN input should have low noise and sufficient filtering to minimize VCXO input voltage modulation, which can result in excessive VCXO and output clock jitter during free run operation.

The 50K potentiometer P1 can be adjusted to set the input voltage to VC\_FREERUN between GND and VDD. A LMP7701 (U8) op amp is used to buffer the voltage divider from P1. As an alternative to using P1, an external voltage can be applied to header JP5 to set the VC\_FREERUN voltage; however, you must initially remove P1 and short R27.

1.8 CONTROL INPUTS

Switch SW1 allows the LMH1982 control inputs to be set to logic high (VDD) or logic low (GND). See for the toggle switch definitions for SW1.

TABLE 6. Control Input Switch, SW1

SWITCH LABEL	LOW	HIGH
REF_SEL	Select REF_A	Select REF_B
I2C_ENA	Enable I2C	Disable I2C
GENLOCK	Genlock Mode	Free Run Mode
RESET	Reset operation	Normal operation

Note: The REF\_SEL and GENLOCK inputs will only be functional after they have been enabled by programming the control registers.

During normal operation, the RESET input must be set high; otherwise the device will not function properly. To reset the control registers of the LMH1982, toggle RESET low for at least 10 μs for proper reset and then set high.

To enable programming via the I2C interface, the I2C\_ENABLE input must be set low. If I2C\_ENABLE is set high and any attempt is made to communicate via I2C, the LMH1982 will not acknowledge, and read/write operations will not occur.

The control inputs can be probed on the inside pins of header J9, while the edge-side pins of J9 are all connected to GND. See Table 7 for the pin assignments of J9. If SW1 is removed, J9 may also be used to apply external logic signals to the control inputs.

TABLE 7. Control Input Test Points, J9

Pin #	Pin Name	Pin #	Pin Name
1	GND	8	REF_SEL
2	GND	7	I2C_ENABLE
3	GND	6	GENLOCK
4	GND	5	RESET

1.9 GENLOCK STATUS INDICATION

The evaluation board has two green LEDs (D3, D4) for visual indication of the PLL lock status and reference status outputs, NO\_LOCK and NO\_REF. In Genlock mode, the PLL lock status is indicated by D3 (labeled "GENLOCKED") and the reference status is indicated by D4 (labeled "REFERENCE"). The NO\_LOCK and NO\_REF outputs can be probed respectively at pins 7 and 8 of header J10.

Refer to the LMH1982 datasheet for more information about programming the PLL lock threshold and loss of reference threshold.

TABLE 8. Genlock Status LEDs

Condition	D3 (NO_LOCK)	D4 (NO_REF)
Genlock mode Reference lost PLL(s) not locked	OFF	OFF
Genlock mode Reference valid PLL(s) locking	OFF	ON
Genlock mode Reference valid PLLs locked	ON	ON

### 1.10 I<sup>2</sup>C INTERFACE

The I<sup>2</sup>C interface clock (SCL) and data (SDA) signals come from the USB board via header J11. These signals can be probed at test points TP11 (SCL) and TP12 (SDA). Both signals traces have 4.7 k $\Omega$  pull-up resistors to VDD and 50 $\Omega$  series resistors to the I<sup>2</sup>C pins of the LMH1982. The I<sup>2</sup>C\_ENABLE input must be set high to allow I<sup>2</sup>C programming.

### 1.11 USB BOARD AND PC SOFTWARE APPLICATION

When connected to the PC the Windows operating system (OS) will interpret the USB board as a Human Interface Device (HID) and use Microsoft's standard HID driver included in the OS. The LMH1982 evaluation software application designed by National can access the USB board through dynamic link libraries, which are used by the PC application to control the LMH1982 using the I<sup>2</sup>C interface. For more information, consult the USB board reference manual and LMH1982 evaluation software user guide.

### 1.12 LIST OF TEST POINTS

TABLE 9. Test Points

Designator	Signal Name
TP1	DVDD
TP2	VCC
TP3	VDD
TP4	VDD_VCXO
TP7	OEOOUT
TP11	SCL
TP12	SDA
Pin 6, J10	TOF_OUT
Pin 7, J10	NO_LOCK
Pin 8, J10	NO_REF
TP21	VCTRL
TP22	XO_OUT
TP23	TOF
TP27	HREF_A
TP28	VREF_A
TP30	HREF_B
TP31	VREF_B

## 2.0 Evaluation Board Schematic

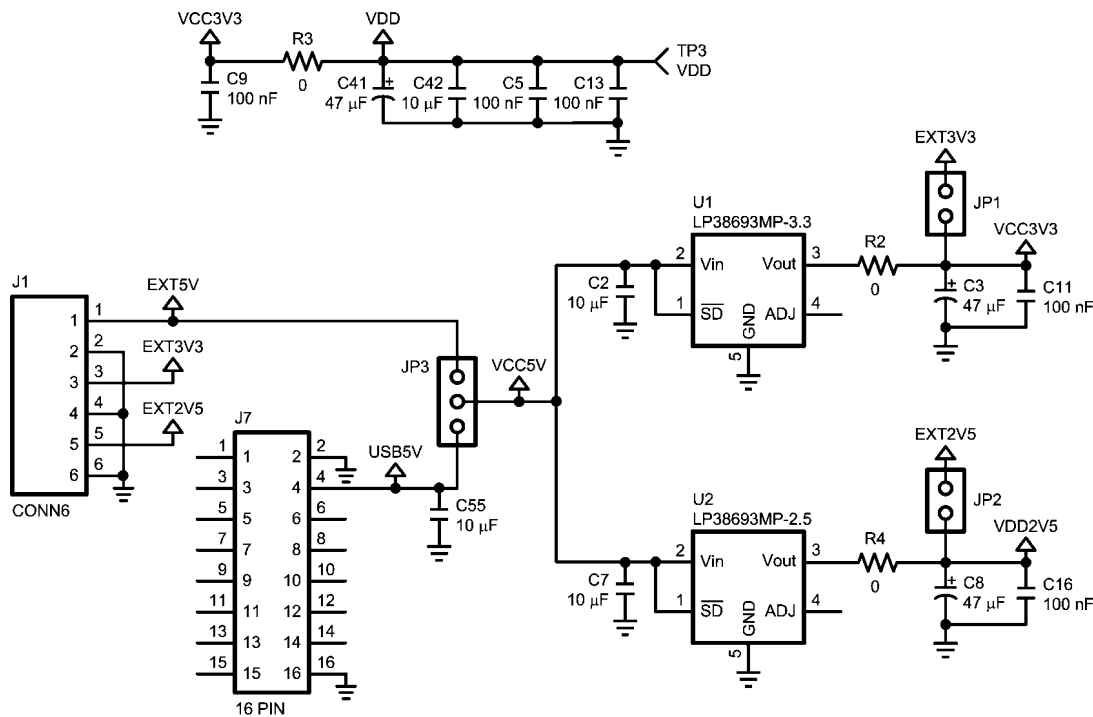

30061903

FIGURE 3. Schematic (1 of 4)  
LP38693 LDO Regulators with External Power Input Header

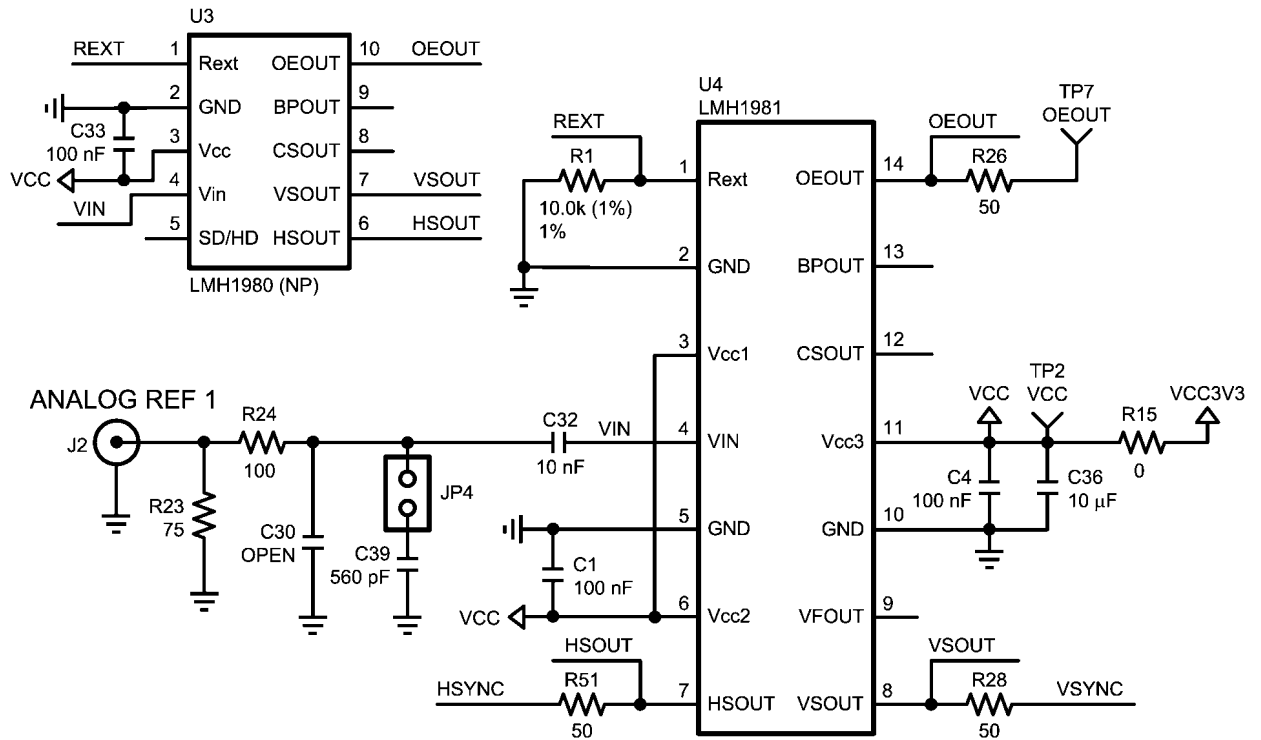

30061904

FIGURE 4. Schematic (2 of 4)  
LMH1981 and LMH1980 Sync Separators

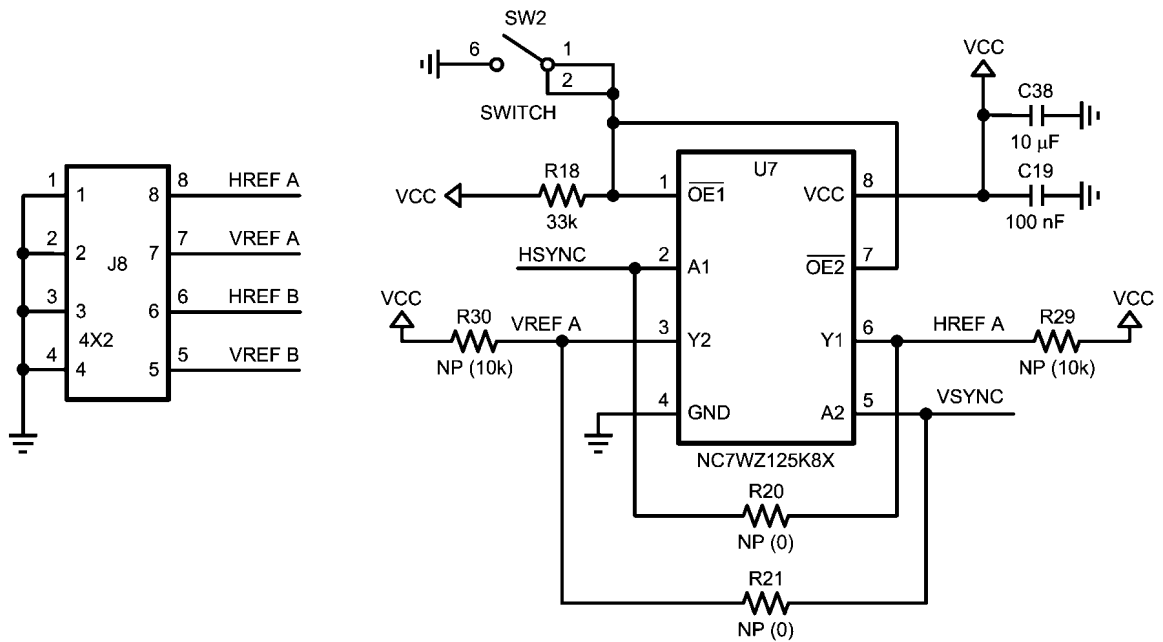

30061905

FIGURE 5. Schematic (3 of 4)  
Input Header and Switch-Controlled Logic Buffer

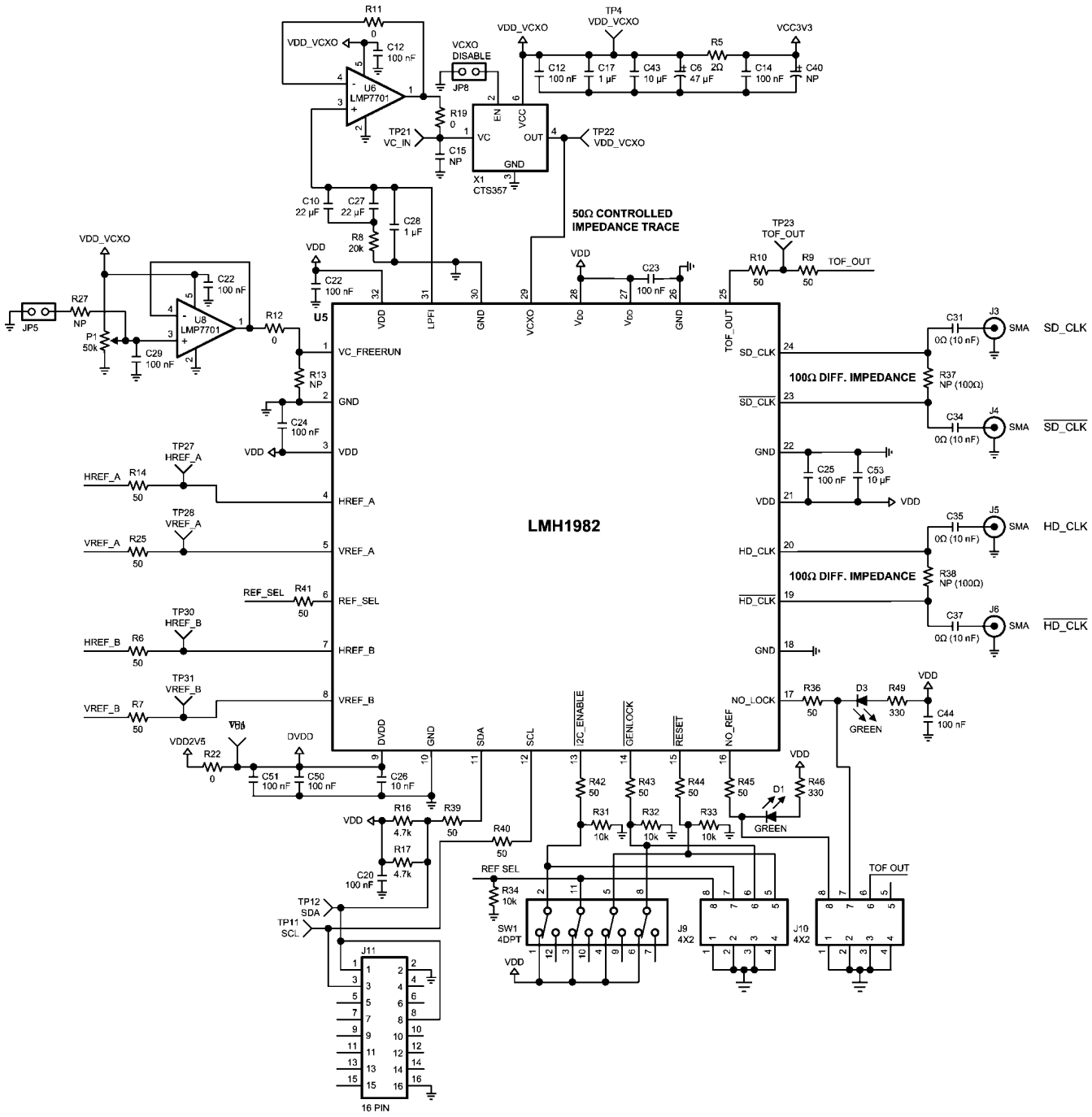

**FIGURE 6. Schematic (4 of 4)  
LMH1982 Clock Generator with Loop Filter, VCXO, and LMP7701 Op Amps**

30061906

### 3.0 Evaluation Board Layout

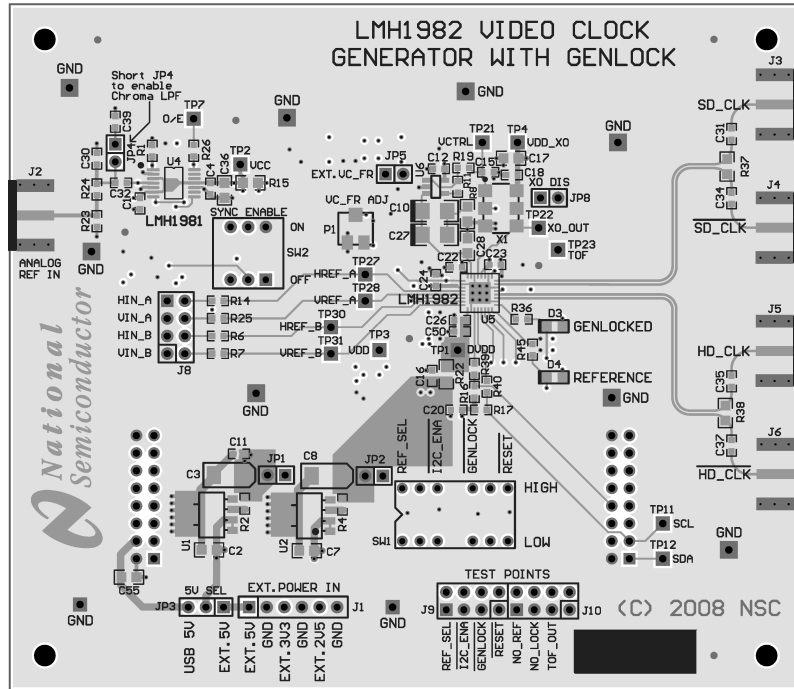

30061907

**FIGURE 7. PCB Layout (1 of 2)**  
**Top Routing Layer 1 (dark gray) and Ground Plane Layer 2 (light gray)**

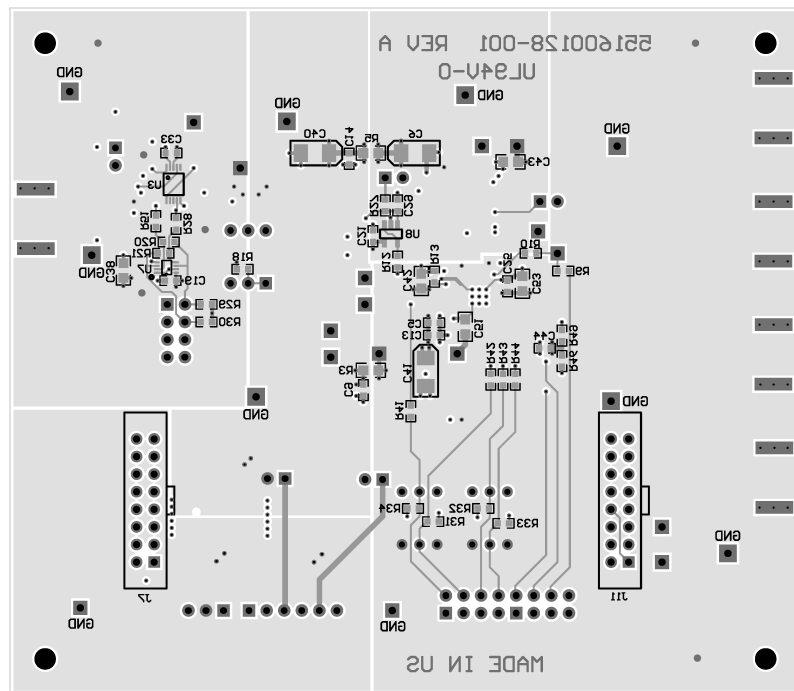

30061908

**FIGURE 8. PCB Layout (2 of 2)**  
**Power Plane Layer 3 (light gray) and Bottom Routing Layer 4 (dark gray)**



## 4.0 Evaluation Board Bill of Materials

Qty	Part Designator	Part Value / Description	Part Footprint
20	C1, C4, C5, C9, C11, C12, C14, C16, C18, C19, C20, C21, C22, C23, C24, C25, C29, C33, C44, C50	100 nF, X7R	0603
1	C51	100 nF, X7R	0805
1	C6	100 nF, X7R	1206
1	C13	100 $\mu$ F, X7R	0603
2	C17, C28	1 $\mu$ F, X7R	0805
8	C2, C7, C38, C42, C43, C53, C55	10 $\mu$ F, X5R	0805
2	C3, C8	47 $\mu$ F, 3528	TANT-B
3	C10, C27, C41	22 $\mu$ F, X5R	1206
2	C26, C32	10 nF, X7R	0603
1	C39	560 pF, NPO	0603
2	D3, D4	GREEN, SMT LED	0805
1	J1	6 PIN HEADER	6X1
1	J2	EDGE MOUNT BNC	SMA
4	J3, J4, J5, J6	EDGE MOUNT SMA	SMA
2	J7, J11	0.100" 16 PIN HEADER	8516-4500PL
3	J8, J9, J10	4X2 HEADER	4X2
4	JP1, JP2, JP4, JP8	2 PIN HEADER	2X1
1	JP3	3 PIN HEADER	3X1
1	P1	50K SMT POT	ST4ETA503CT-ND
7	R1, R29, R30, R31, R32, R33, R34	10.0K 1%	0603
9	R2, R4, R11, R12, R19, C31, C34, C35, C37	0	0603
3	R3, R15, R22	0	0805
1	R5	2.0	0805
17	R6, R7, R10, R14, R25, R26, R28, R36, R39, R40, R41, R42, R43, R44, R45, R51	49.9	0603
1	R8	20K	0805
2	R16, R17	4.7K	0603
1	R23	75	0603
1	R18	33K	0603
1	R24	100	0603
2	R37, R38	100 (NP)	1206
2	R46, R49	330	0603
1	SW1	4PDT SWITCH	4PDT
1	SW2	SPDT SWITCH	SPDT
4	TP1, TP2, TP3, TP4	RED TEST POINT	TEST_POINT
10	TP7, TP11, TP12, TP21, TP22, TP23, TP27, TP28, TP30, TP31	WHITE TEST POINT	TEST_POINT
12	GND	BLACK TEST POINT	TEST_POINT
1	U1	LP38693MP-3.3	SOT223-5
1	U2	LP38693MP-2.5	SOT223-5
1	U3	LMH1980 (NP)	MSOP10
1	U4	LMH1981	TSSOP14
1	U5	LMH1982	LLP-32
2	U6, U8	LMP7701	SOT23-5
1	U7	NC7WZ125K8X	US-8
1	X1	CTS 357LB3I27M0000 27 MHz VCXO	VCXO

Qty	Part Designator	Part Value / Description	Part Footprint
4		7/8" 4-40 THREADED NYLON STANDOFF	
4		3/8" 4-40 SCREW	
	C15, C30, C40, R13, R20, R21, R27	NP	

NP = Not Populated

## 5.0 References

- Gerber Files: LMH1982 Evaluation PCB Layout (available upon request)
- Datasheet: LMH1982 Multi-rate Video Clock Generator with Genlock
- Software Manual: LMH1982 Evaluation Software Application User Guide
- Reference Manual: USB Interface Module for Applications
- Datasheet: LMH1981 Multi-Format Video Sync Separator with 50% Sync Slicing
- Datasheet: LMH1980 Auto-Detecting SD/HD/PC Video Sync Separator
- Application Note: AN-1187 Leadless Leadframe Package (LLP)
- LLP Design Rules: 0.5 mm Pitch LLP Layout and Assembly Design Guidelines
- Gerber Files: SQA32A 32-pin LLP Footprint



## Notes

For more National Semiconductor product information and proven design tools, visit the following Web sites at:

Products		Design Support	
Amplifiers	<a href="http://www.national.com/amplifiers">www.national.com/amplifiers</a>	WEBENCH	<a href="http://www.national.com/webench">www.national.com/webench</a>
Audio	<a href="http://www.national.com/audio">www.national.com/audio</a>	Analog University	<a href="http://www.national.com/AU">www.national.com/AU</a>
Clock Conditioners	<a href="http://www.national.com/timing">www.national.com/timing</a>	App Notes	<a href="http://www.national.com/appnotes">www.national.com/appnotes</a>
Data Converters	<a href="http://www.national.com/adc">www.national.com/adc</a>	Distributors	<a href="http://www.national.com/contacts">www.national.com/contacts</a>
Displays	<a href="http://www.national.com/displays">www.national.com/displays</a>	Green Compliance	<a href="http://www.national.com/quality/green">www.national.com/quality/green</a>
Ethernet	<a href="http://www.national.com/ethernet">www.national.com/ethernet</a>	Packaging	<a href="http://www.national.com/packaging">www.national.com/packaging</a>
Interface	<a href="http://www.national.com/interface">www.national.com/interface</a>	Quality and Reliability	<a href="http://www.national.com/quality">www.national.com/quality</a>
LVDS	<a href="http://www.national.com/lvds">www.national.com/lvds</a>	Reference Designs	<a href="http://www.national.com/refdesigns">www.national.com/refdesigns</a>
Power Management	<a href="http://www.national.com/power">www.national.com/power</a>	Feedback	<a href="http://www.national.com/feedback">www.national.com/feedback</a>
Switching Regulators	<a href="http://www.national.com/switchers">www.national.com/switchers</a>		
LDOs	<a href="http://www.national.com/lido">www.national.com/lido</a>		
LED Lighting	<a href="http://www.national.com/led">www.national.com/led</a>		
PowerWise	<a href="http://www.national.com/powerwise">www.national.com/powerwise</a>		
Serial Digital Interface (SDI)	<a href="http://www.national.com/sdi">www.national.com/sdi</a>		
Temperature Sensors	<a href="http://www.national.com/tempsensors">www.national.com/tempsensors</a>		
Wireless (PLL/VCO)	<a href="http://www.national.com/wireless">www.national.com/wireless</a>		

THE CONTENTS OF THIS DOCUMENT ARE PROVIDED IN CONNECTION WITH NATIONAL SEMICONDUCTOR CORPORATION ("NATIONAL") PRODUCTS. NATIONAL MAKES NO REPRESENTATIONS OR WARRANTIES WITH RESPECT TO THE ACCURACY OR COMPLETENESS OF THE CONTENTS OF THIS PUBLICATION AND RESERVES THE RIGHT TO MAKE CHANGES TO SPECIFICATIONS AND PRODUCT DESCRIPTIONS AT ANY TIME WITHOUT NOTICE. NO LICENSE, WHETHER EXPRESS, IMPLIED, ARISING BY ESTOPPEL OR OTHERWISE, TO ANY INTELLECTUAL PROPERTY RIGHTS IS GRANTED BY THIS DOCUMENT.

TESTING AND OTHER QUALITY CONTROLS ARE USED TO THE EXTENT NATIONAL DEEMS NECESSARY TO SUPPORT NATIONAL'S PRODUCT WARRANTY. EXCEPT WHERE MANDATED BY GOVERNMENT REQUIREMENTS, TESTING OF ALL PARAMETERS OF EACH PRODUCT IS NOT NECESSARILY PERFORMED. NATIONAL ASSUMES NO LIABILITY FOR APPLICATIONS ASSISTANCE OR BUYER PRODUCT DESIGN. BUYERS ARE RESPONSIBLE FOR THEIR PRODUCTS AND APPLICATIONS USING NATIONAL COMPONENTS. PRIOR TO USING OR DISTRIBUTING ANY PRODUCTS THAT INCLUDE NATIONAL COMPONENTS, BUYERS SHOULD PROVIDE ADEQUATE DESIGN, TESTING AND OPERATING SAFEGUARDS.

EXCEPT AS PROVIDED IN NATIONAL'S TERMS AND CONDITIONS OF SALE FOR SUCH PRODUCTS, NATIONAL ASSUMES NO LIABILITY WHATSOEVER, AND NATIONAL DISCLAIMS ANY EXPRESS OR IMPLIED WARRANTY RELATING TO THE SALE AND/OR USE OF NATIONAL PRODUCTS INCLUDING LIABILITY OR WARRANTIES RELATING TO FITNESS FOR A PARTICULAR PURPOSE, MERCHANTABILITY, OR INFRINGEMENT OF ANY PATENT, COPYRIGHT OR OTHER INTELLECTUAL PROPERTY RIGHT.

### LIFE SUPPORT POLICY

**NATIONAL'S PRODUCTS ARE NOT AUTHORIZED FOR USE AS CRITICAL COMPONENTS IN LIFE SUPPORT DEVICES OR SYSTEMS WITHOUT THE EXPRESS PRIOR WRITTEN APPROVAL OF THE CHIEF EXECUTIVE OFFICER AND GENERAL COUNSEL OF NATIONAL SEMICONDUCTOR CORPORATION.** As used herein:

Life support devices or systems are devices which (a) are intended for surgical implant into the body, or (b) support or sustain life and whose failure to perform when properly used in accordance with instructions for use provided in the labeling can be reasonably expected to result in a significant injury to the user. A critical component is any component in a life support device or system whose failure to perform can be reasonably expected to cause the failure of the life support device or system or to affect its safety or effectiveness.

National Semiconductor and the National Semiconductor logo are registered trademarks of National Semiconductor Corporation. All other brand or product names may be trademarks or registered trademarks of their respective holders.

Copyright© 2008 National Semiconductor Corporation

For the most current product information visit us at [www.national.com](http://www.national.com)



**National Semiconductor Americas Technical Support Center**  
 Email: [support@nsc.com](mailto:support@nsc.com)  
 Tel: 1-800-272-9959

**National Semiconductor Europe Technical Support Center**  
 Email: [europe.support@nsc.com](mailto:europe.support@nsc.com)  
 German Tel: +49 (0) 180 5010 771  
 English Tel: +44 (0) 870 850 4288

**National Semiconductor Asia Pacific Technical Support Center**  
 Email: [ap.support@nsc.com](mailto:ap.support@nsc.com)

**National Semiconductor Japan Technical Support Center**  
 Email: [jpn.feedback@nsc.com](mailto:jpn.feedback@nsc.com)