

KIT33932VWEVBE Evaluation Board

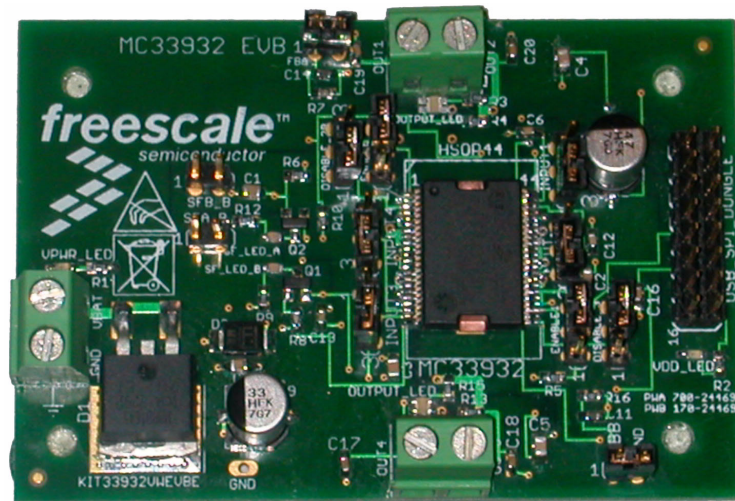

Figure 1. Evaluation Board

Table of Contents

Kit Contents / Packing List	2
Important Notice	3
Kit Introduction	4
Hardware Description	5
Setup and Example Demonstrations	8
EVB Schematic	9
Board Layout	10
Bill of Material	12
References	14
Revision History	15

1 Kit Contents / Packing List

- Evaluation Board - KIT33932VWEVBE
- Hardware Document CD, CD33932

2 Important Notice

Freescale provides the enclosed product(s) under the following conditions:

This evaluation kit is intended for use of ENGINEERING DEVELOPMENT OR EVALUATION PURPOSES ONLY. It is provided as a sample IC pre-soldered to a printed circuit board to make it easier to access inputs, outputs, and supply terminals. This EVB may be used with any development system or other source of I/O signals by simply connecting it to the host MCU or computer board via off-the-shelf cables. This EVB is not a Reference Design and is not intended to represent a final design recommendation for any particular application. Final device in an application will be heavily dependent on proper printed circuit board layout and heat sinking design as well as attention to supply filtering, transient suppression, and I/O signal quality.

The goods provided may not be complete in terms of required design, marketing, and or manufacturing related protective considerations, including product safety measures typically found in the end product incorporating the goods. Due to the open construction of the product, it is the user's responsibility to take any and all appropriate precautions with regard to electrostatic discharge. In order to minimize risks associated with the customers applications, adequate design and operating safeguards must be provided by the customer to minimize inherent or procedural hazards. For any safety concerns, contact Freescale sales and technical support services.

Should this evaluation kit not meet the specifications indicated in the kit, it may be returned within 30 days from the date of delivery and will be replaced by a new kit.

Freescale reserves the right to make changes without further notice to any products herein. Freescale makes no warranty, representation or guarantee regarding the suitability of its products for any particular purpose, nor does Freescale assume any liability arising out of the application or use of any product or circuit, and specifically disclaims any and all liability, including without limitation consequential or incidental damages. "Typical" parameters can and do vary in different applications and actual performance may vary over time. All operating parameters, including "Typical", must be validated for each customer application by customer's technical experts.

Freescale does not convey any license under its patent rights nor the rights of others. Freescale products are not designed, intended, or authorized for use as components in systems intended for surgical implant into the body, or other applications intended to support or sustain life, or for any other application in which the failure of the Freescale product could create a situation where personal injury or death may occur.

Should Buyer purchase or use Freescale products for any such unintended or unauthorized application, Buyer shall indemnify and hold Freescale and its officers, employees, subsidiaries, affiliates, and distributors harmless against all claims, costs, damages, and expenses, and reasonable attorney fees arising out of, directly or indirectly, any claim of personal injury or death associated with such unintended or unauthorized use, even if such claim alleges that Freescale was negligent regarding the design or manufacture of the part. Freescale™ and the Freescale logo are trademarks of Freescale Semiconductor, Inc. All other product or service names are the property of their respective owners. © Freescale Semiconductor, Inc. 2008

3 Kit Introduction

- The **KIT33932VWEVBE** Evaluation Board (EVB) is an easy-to-use circuit board that allows the user to exercise all the functions of the MC33932 H-Bridge circuit. The EVB communicates to a PC through a USB/SPI Dongle connected to the PC's USB port. The Freescale SPIGen program provides the User Interface to the MC33932 EVB's SPI port and allows the user to send commands to the IC.

4 Hardware Description

The Hardware Block Diagram is shown below:

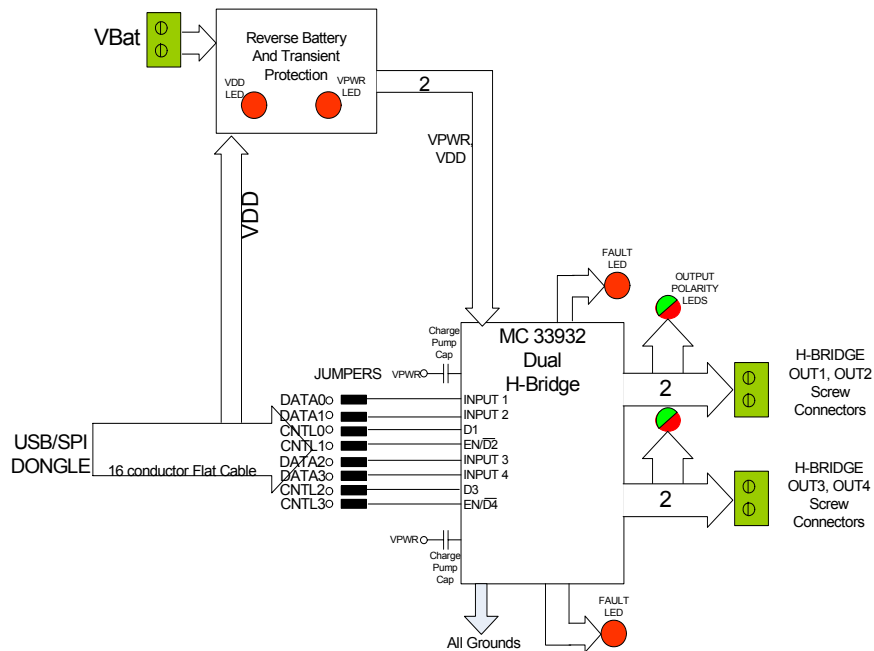

Figure 1. Block Diagram

This EVB consists of a Dual H-Bridge, a USB to SPI Dongle interface, power conditioning circuitry, and a set of 8 Input Select Jumpers. All +5 volt VDD power required by the EVB is obtained via the USB/SPI Dongle interface.

4.1 LED Display

Several LED's are provided as visual output devices for the EVB. A list of the LED devices is shown below:

1. VDD LED - Indicates when +5 Volt supply is connected
2. VPWR LED - Indicates when +12 Volt supply is connected
3. Fault LEDs - Illuminates when one of the H-Bridges detects a fault
4. Output LEDs - Red/Green LED, for each H-Bridge, that indicates which direction the current is flowing in the legs of the H-Bridge.

4.2 I/O Jumper Definitions (J3)

The EVB contains seven jumpers that connect the inputs of the 33932 as follows (**Bold** = factory setting):

JUMPER NAME	JUMPER POSITION	CONNECTION
INPUT 1	1-2/ 2-3	GND/ DATA0
INPUT 2	1-2/ 2-3	GND/ DATA1
INPUT3	1-2/ 2-3	GND/ DATA2
INPUT4	1-2/ 2-3	GND/ DATA3
ENABLE/DISABLE 2	1-2/ 2-3	PullUp/CNTL1

ENABLE/DISABLE 4	1-2/2-3	PullUp/CNTL3
DISABLE 1	1-2/2-3	CNTL0/GND
DISABLE_2B	1-2/2-3	GND/CNTL2

The DATA0 -DATA3 and CNTL0 - CNTL3 signals are parallel outputs from the USB/SPI Dongle that can be controlled directly from the SPIGen program. An example config file called "MC33932_EVB_CONFIGURATION_FILE.spi" is provided on the CD which contains a batch file example.

If the user prefers to supply the various MC33932 input signals externally, other than from the USB-SPI Interface, the jumpers can be removed and connections can be made to the open pin number 2' s.

4.3 USB/SPI Dongle Connector

The USB/SPI dongle connector is a 16 pin,.1" center, dual-row connector that is designed to interface directly to the USB/SPI Dongle unit. The USB/SPI dongle connector consists of the following 16 pins –

<u>Pin Number</u>	<u>Name</u>	<u>Description</u>
1	CSB	SPI signal, Chip Select Bar
2	CNTL2	Parallel port signal CNTL2
3	SO	SPI signal, Serial Out
4	CNTL1	Parallel port signal CNTL1
5	SI	SPI signal, Serial In
6	CNTL0	Parallel port signal CNTL0
7	SCLK	SPI signal, Serial Clock
8	DATA4	Parallel port signal DATA4
9	CNTL3	Parallel port signal CNTL3
10	DATA3	Parallel port signal DATA3
11	VDD	+5 Volt VDD from USB
12	DATA2	Parallel port signal DATA2
13	NC	Unused
14	DATA1	Parallel port signal DATA1
15	GND	Signal Ground
16	DATA0	Parallel port signal DATA0

This connector mates with the 16 conductor flat cable that connects to the USB/SPI Dongle (KITUSBSPIDGLEVME).

4.4 Screw Terminal Connections

The EVB contains input and output screw terminal connections to allow easy access to the MC33932's drive circuits. The diagram below shows the locations of the screw terminals and their functional definitions:

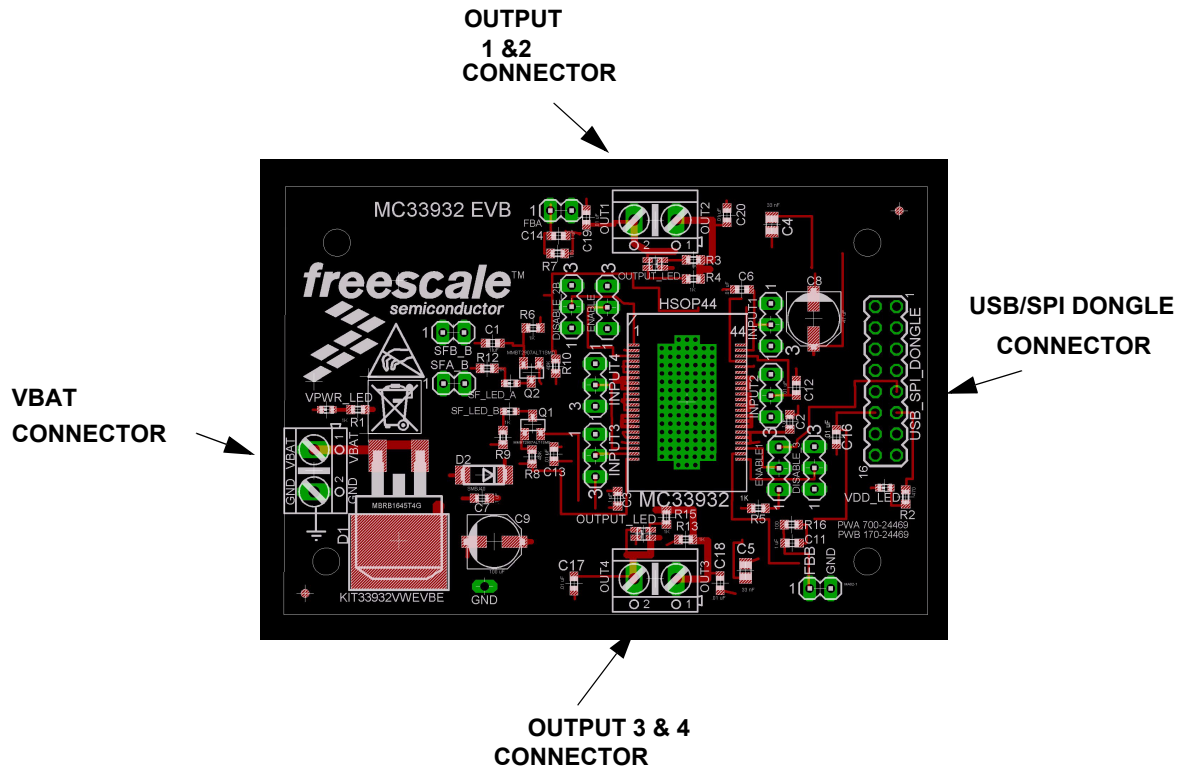

Figure 2. Screw Terminals with Definitions

4.5 VBAT Connector

The VBAT Connector is a 2 position screw terminal that provides +12 Volt and Ground Terminals. The Ground terminal is marked "GND" and the +12 Volt Terminal is marked "VBAT".

4.6 H-Bridge Output Connectors

The H-Bridge Output Connectors are 2 position screw terminals that provides the following two connections:

- 1) Output 1/2 of the H-Bridge
- 2) Output 3/4 of the H-Bridge

For H-Bridge A the output 1 connector is labeled "OUT1"

For H-Bridge A the output 2 connector is labeled "OUT2"

For H-Bridge B the output 3 connector is labeled "OUT3"

For H-Bridge B the output 4 connector is labeled "OUT4"

5 Setup and Example Demonstrations

To perform the examples included in the CD the following connections and setup must be performed:

1. Make sure the SPIGen 5.0X program is installed on the PC and it can communicate with the USB/SPI Dongle as described in that kit's documentation.
2. Connect the USB/SPI Dongle to the EVB via a 16 pin ribbon cable. Make sure to orient the cable so that pin1 on both the USB/SPI Dongle and the EVB are connected correctly, pin 1 to pin 1.
3. Connect the USB/SPI Dongle to a PC, LED 2 on the USB/SPI Dongle and the VDD LED on the board should both be illuminated.
4. Attach a +12 VDC supply (do not turn on power yet) to the power connector on the EVB, making sure to observe the GND and +12V terminals. The current capability of the +12V supply should exceed the maximum total current that the number of simultaneously ON loads will require.
5. Attach loads to the OUT1/2 and OUT3/4 terminals . One possible demo load is a 10w halogen G4 Base T3 bulb (used in landscape lighting applications). This load will draw approximately 850 mA and fits nicely into the screw terminals.
6. Launch SPIGen and from the **"File"** menu, select **"Open"** and browse to the CD containing the "MC33932_EVB_CONFIGURATION_FILE.spi" file. The title on the SPIGen screen should change from "Generic SPI Generator" to "MC33932 SPI Generator".
7. Turn on the +12 Volt Supply. Verify that all is working correctly by clicking on the "Extra Pins" button in the SPIGen main screen and then click on the following buttons to set the up the proper conditions:
 - A. Control 0 **"Low"**
 - B. Control 1 **"High"**
 - C. Control 2 **"Low"**
 - D. Control 3 **"High"**
8. Next, click on the Data 0 **"High"** button. The OUT1/2 load or bulb should turn on. The OUT 1/2 LED should be glowing green. Clicking on the DATA 0 **"Low"** button should turn off the load or bulb and the OUT 1/2 LED.
Next, click on the Data 1 **"High"** button. The OUT1/2 load or bulb should turn on. The OUT 1/2 LED should be glowing red. Clicking on the DATA 1 **"Low"** button should turn off the load or bulb and the OUT 1/2 LED.
9. Next, click on the Data 2 **"High"** button. The OUT3/4 load or bulb should turn on. The OUT 3/4 LED should be glowing green. Clicking on the DATA 2 **"Low"** button should turn off the load or bulb and the OUT 3/4 LED.
10. Next, click on the Data 3 **"High"** button. The OUT3/4 load or bulb should turn on. The OUT 3/4 LED should be glowing red. Clicking on the DATA 3 **"Low"** button should turn off the load or bulb and the OUT 3/4 LED. If everything described so far occurs then you are ready to proceed with the remaining examples.

EXAMPLE 1. RUNNING THE TEST BOTH H-BRIDGES BATCH FILE

1. Click on the "Send a Batch of Commands" Tab in the SPIGen main screen.
2. In the box below the "Commands to Send:" column is a pull-down menu box containing several batch file names. One of these example batch files is labeled **"Test Both H-Bridges"**.
3. Click on this label to load it. You should see a list of commands in the "Command to Send" box.
4. Click on the **"Continuous"** button and observe that the loads or bulbs you have attached to the EVB board are blinking twice and then going out in succession.

There are other demo batch examples that can be run and examined for learning how to use the EVB.

7 Board Layout

7.1 Assembly Layer Top

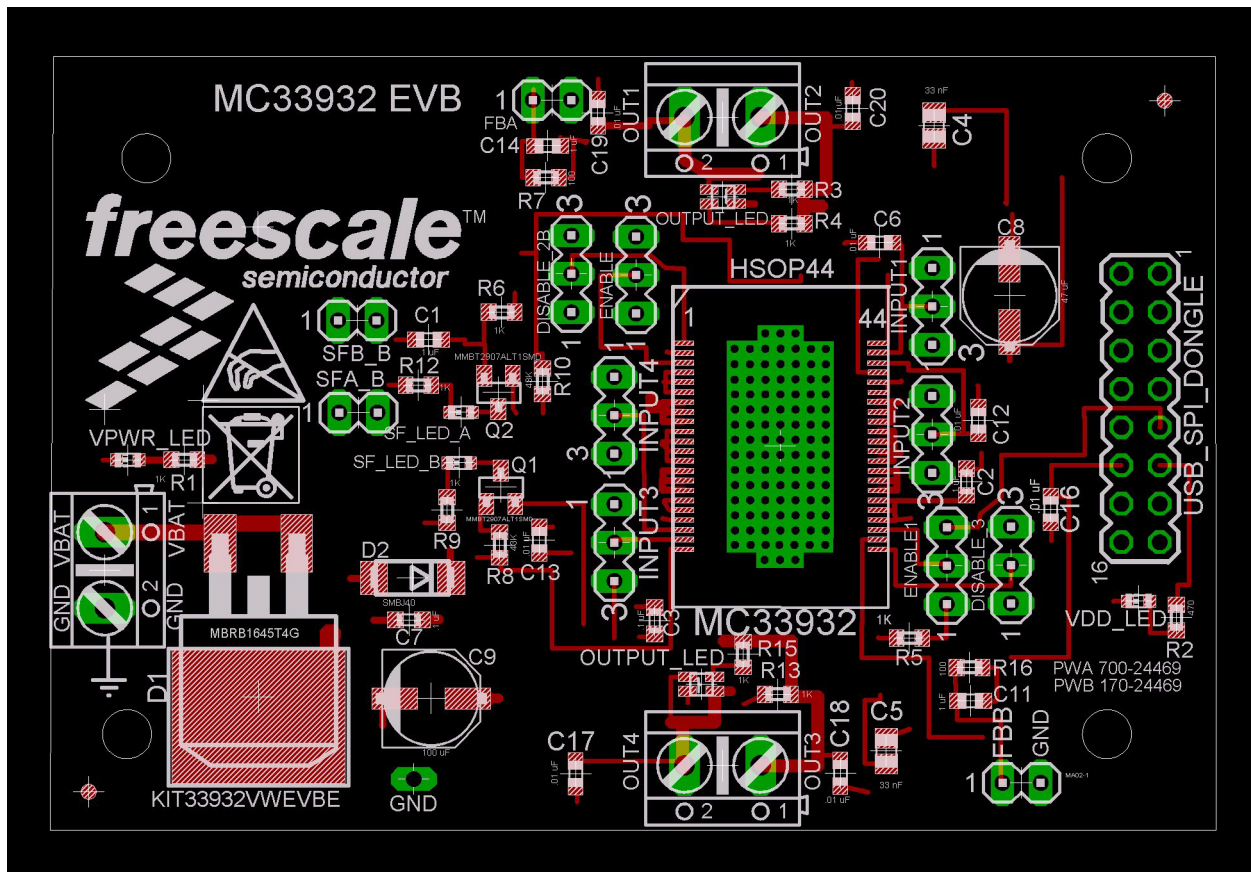

Figure 2. Assembly Layer Top

7.2 Assembly Layer Bottom

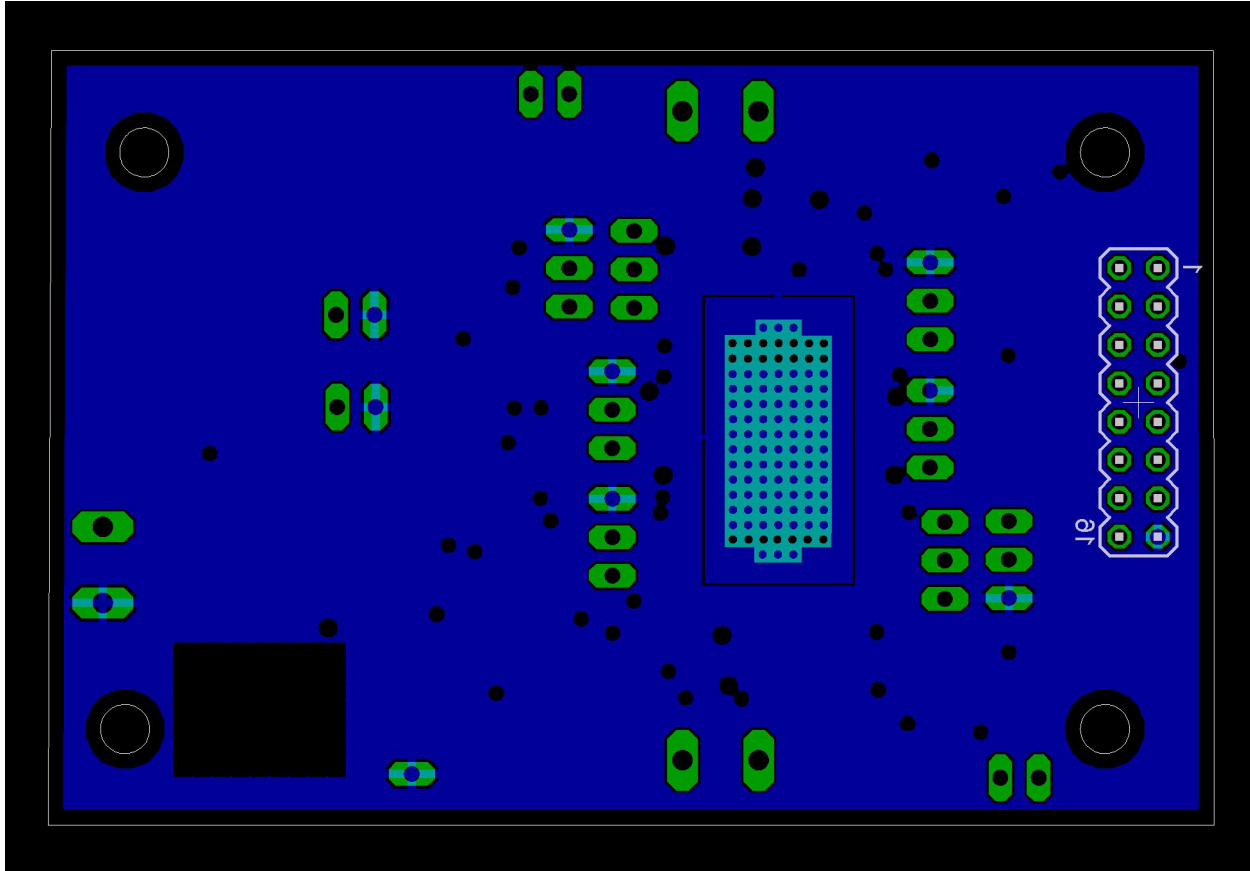

Figure 3. Assembly Layer Bottom

8 Bill of Material

Reference Designation	Value	Package	Description	Mfr	PN
Freescale Components					
U7	MC33932	HSOP44	Freescale 5.0A Throttle Control H-Bridge	Freescale	MC34700EP
Capacitors					
C1	.1uF	C0603	CAP .1UF 25V CERAMIC X7R 0603		399-1281-1-ND
C2	.1uF	C0603	CAP .1UF 25V CERAMIC X7R 0603		399-1281-1-ND
C3	.1uF	C0603	CAP .1UF 25V CERAMIC X7R 0603		399-1281-1-ND
C4	33nF	C0805	CAP 33000PF 50V CERM X7R 0805		PCC1834CT-ND
C5	33nF	C0805	CAP 33000PF 50V CERM X7R 0805		PCC1834CT-ND
C6	.01uF	C0603			
C7	.1uF	C0603			
C8	47uF	PANASONIC_D			
C9	100uF	PANASONIC_D			
C11	1uF	C0603			
C12	.01uF	C0603			
C13	.01uF	C0603			
C14	1uF	C0603			
C16	.01uF	C0603			
C17	.01uF	C0603			
C18	.01uF	C0603			
C19	.01uF	C0603			
C20	.01uF	C0603			
Resistors					
R1	1K	R0603			
R2	470	R0603			
R3	1K	R0603			
R4	1K	R0603			
R5	1K	R0603			
R6	1K	R0603			
R7	100	R0603			
R8	43K	R0603			
R9	1K	R0603			
R10	43K	R0603			
R12	1K	R0603			
R13	1K	R0603			
R15	1K	R0603			
R16	100	R0603			
Diodes					
D1	MBRB164 5T4G	D2PAK			
D2	SMBJ40	DO214AA			

Reference Designation	Value	Package	Description	Mfr	PN
Other					
DISABLE_2B	MA03-1	MA03-1			
DISABLE_3	MA03-1	MA03-1			
ENABLE	MA03-1	MA03-1			
ENABLE1	MA03-1	MA03-1			
FBA	MA02-1	MA02-1			
FBB	MA02-1	MA02-1			
GND	MA01-1	MA01-1			
INPUT1	MA03-1	MA03-1			
INPUT2	MA03-1	MA03-1			
INPUT3	MA03-1	MA03-1			
INPUT4	MA03-1	MA03-1			
OUTPUT_A		AK500/2			
OUTPUT_B		AK500/2			
OUTPUT_LED_A	LT1ED67A	1.6X1.6			
OUTPUT_LED1	LT1ED67A	1.6X1.6			
Q1	MMBT2907ALT1SMD	SOT23-BEC			
Q2	MMBT2907ALT1SMD	SOT23-BEC			
SFA_B	MA02-1	MA02-1			
SFB_B	MA02-1	MA02-1			
SF_LED_A		CHIP-LED0603			
SF_LED_B		CHIP-LED0603			
USB_SPLI_DONGLE	MA08-2	MA08-2			
VBAT		AK500/2			
VDD_LED		CHIP-LED0603			
VPWR_LED		CHIP-LED0603			

Freescale does not assume liability, endorse, or warrant components from external manufacturers that are referenced in circuit drawings or tables. While Freescale offers component recommendations in this configuration, it is the customer's responsibility to validate their application

9 References

Following are URLs where you can obtain information on other Freescale products and application solutions:

Description	URL
Data Sheet - MC34932	www.freescale.com/files/analog/doc/data_sheet/MC33932.pdf
Freescale's Web Site	www.freescale.com
Freescale's Analog Web Site	www.freescale.com/analog

10 Revision History

REVISION	DATE	DESCRIPTION OF CHANGES
1.0	7/2008	<ul style="list-style-type: none">Initial Release

How to Reach Us:

Home Page:

www.freescale.com

Web Support:

<http://www.freescale.com/support>

USA/Europe or Locations Not Listed:

Freescale Semiconductor, Inc.
Technical Information Center, EL516
2100 East Elliot Road
Tempe, Arizona 85284
+1-800-521-6274 or +1-480-768-2130
www.freescale.com/support

Europe, Middle East, and Africa:

Freescale Halbleiter Deutschland GmbH
Technical Information Center
Schatzbogen 7
81829 Muenchen, Germany
+44 1296 380 456 (English)
+46 8 52200080 (English)
+49 89 92103 559 (German)
+33 1 69 35 48 48 (French)
www.freescale.com/support

Japan:

Freescale Semiconductor Japan Ltd.
Headquarters
ARCO Tower 15F
1-8-1, Shimo-Meguro, Meguro-ku,
Tokyo 153-0064
Japan
0120 191014 or +81 3 5437 9125
support.japan@freescale.com

Asia/Pacific:

Freescale Semiconductor Hong Kong Ltd.
Technical Information Center
2 Dai King Street
Tai Po Industrial Estate
Tai Po, N.T., Hong Kong
+800 2666 8080
support.asia@freescale.com

For Literature Requests Only:

Freescale Semiconductor Literature Distribution Center
P.O. Box 5405
Denver, Colorado 80217
1-800-441-2447 or 303-675-2140
Fax: 303-675-2150
LDCForFreescaleSemiconductor@hibbertgroup.com

RoHS-compliant and/or Pb-free versions of Freescale products have the functionality and electrical characteristics of their non-RoHS-compliant and/or non-Pb-free counterparts. For further information, see <http://www.freescale.com> or contact your Freescale sales representative.

For information on Freescale's Environmental Products program, go to <http://www.freescale.com/epp>.

Information in this document is provided solely to enable system and software implementers to use Freescale Semiconductor products. There are no express or implied copyright licenses granted hereunder to design or fabricate any integrated circuits or integrated circuits based on the information in this document.

Freescale Semiconductor reserves the right to make changes without further notice to any products herein. Freescale Semiconductor makes no warranty, representation or guarantee regarding the suitability of its products for any particular purpose, nor does Freescale Semiconductor assume any liability arising out of the application or use of any product or circuit, and specifically disclaims any and all liability, including without limitation consequential or incidental damages. "Typical" parameters that may be provided in Freescale Semiconductor data sheets and/or specifications can and do vary in different applications and actual performance may vary over time. All operating parameters, including "Typicals", must be validated for each customer application by customer's technical experts. Freescale Semiconductor does not convey any license under its patent rights nor the rights of others. Freescale Semiconductor products are not designed, intended, or authorized for use as components in systems intended for surgical implant into the body, or other applications intended to support or sustain life, or for any other application in which the failure of the Freescale Semiconductor product could create a situation where personal injury or death may occur. Should Buyer purchase or use Freescale Semiconductor products for any such unintended or unauthorized application, Buyer shall indemnify and hold Freescale Semiconductor and its officers, employees, subsidiaries, affiliates, and distributors harmless against all claims, costs, damages, and expenses, and reasonable attorney fees arising out of, directly or indirectly, any claim of personal injury or death associated with such unintended or unauthorized use, even if such claim alleges that Freescale Semiconductor was negligent regarding the design or manufacture of the part.

Freescale™ and the Freescale logo are trademarks of Freescale Semiconductor, Inc. All other product or service names are the property of their respective owners.

© Freescale Semiconductor, Inc., 2009. All rights reserved.