

30091402

FIGURE 2. Evaluation Board Schematic

## Theory of Operation

The LM25061 provides intelligent control of the power supply connections of a load which is to be connected to a live power source. The two primary functions of a hot swap circuit are in-rush current limiting during turn-on, and monitoring of the load current for faults during normal operation. Additional functions include Under-Voltage Lock-Out (UVLO) to ensure voltage is supplied to the load only when the system input voltage is above a threshold, power limiting in the series pass FET (Q1) during turn-on, and a Power Good logic output (PGD) to indicate the circuit status.

Upon applying the input voltage to the LM25061 (e.g., SW1 is switched on), Q1 is initially held off for the insertion delay ( $\approx 213$  ms) to allow ringing and transients at the input to subside. At the end of the insertion delay, if the input voltage at VIN is above the UVLO threshold, Q1 is turned on in a controlled manner to limit the in-rush current. If the in-rush current were not limited during turn-on, the current would be high (very high!) as the load capacitors (C3, C4) charge up, limited only by the surge current capability of the voltage source, C7's characteristics, and the wiring resistance (a few milliohms). That very high current could damage the edge connector, PC board traces, and possibly the load capacitors receiving the high current. Additionally, the  $dV/dt$  at the load's input is controlled to reduce possible EMI problems.

The LM25061 limits in-rush current to a safe level using a two step process. In the first portion of the turn-on cycle, when the voltage differential across Q1 is highest, Q1's power dissipation is limited to a peak of 15W by monitoring its drain current (the voltage across R10) and its drain-to-source voltage. Their product is maintained constant by controlling the drain current as the drain-to-source voltage decreases (as the output voltage increases). This is shown in the constant power

portion of *Figure 3* where the drain current is increasing to  $I_{LIM}$ . When the drain current reaches the current limit threshold (5 Amps), it is then maintained constant as the output voltage continues to increase. When the output voltage reaches the input voltage ( $V_{DS}$  decreases to near zero), the drain current then reduces to a value determined by the load. Q1's gate-to-source voltage then increases to its final value. The circuit is now in normal operation mode.

Monitoring of the load current for faults during normal operation is accomplished using the current limit circuit described above. If the load current increases to 5 Amps (50 mV across R10), Q1's gate is controlled to prevent the current from increasing further. When current limiting takes effect, the fault timer limits the duration of the fault. At the end of the fault timeout period Q1 is shut off, denying current to the load. The LM25061-2 then initiates a restart every 1.8 seconds. The restart consists of turning on Q1 and monitoring the load current to determine if the fault is still present. After the fault is removed, the circuit powers up to normal operation at the next restart.

In a sudden overload condition (e.g., the output is shorted to ground), it is possible the current could increase faster than the response time of the current limit circuit. In this case, the circuit breaker sensor shuts off Q1's gate rapidly when the voltage across R10 reaches  $\approx 95$  mV. When the current reduces to the current limit threshold, the current limit circuitry then takes over.

The PGD logic level output is low during turn-on, and switches high when the output voltage at OUT is above 13V. PGD switches low when the voltage at OUT is below 12.5V. The high level voltage at PGD can be any appropriate voltage up to +17V, and can be higher or lower than the voltages at VIN and OUT.

The UVLO thresholds are set by resistors R1 and R2 and the PGD thresholds are set by resistors R3 and R4. Internal cur-

rent sources at the UVLO pin and the FB pin provide hysteresis for the thresholds.

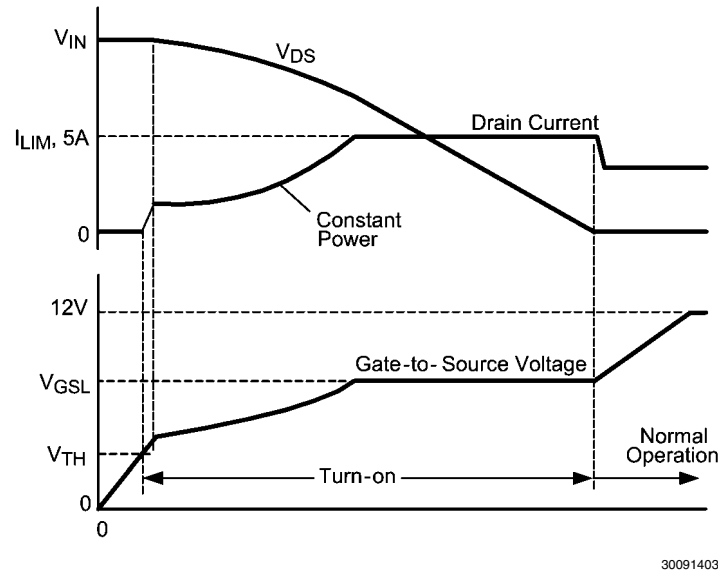

FIGURE 3. Power Up Using Power Limit and Current Limit

## Board Layout and Probing Cautions

The pictorial in *Figure 1* shows the placement of the circuit components. The following should be kept in mind when the board is powered:

1. Use CAUTION when probing the circuit to prevent injury, as well as possible damage to the circuit.
2. At maximum load current (5A), the wire size and length used to connect the power source and the load become important. The wires connecting this evaluation board to the power source SHOULD BE TWISTED TOGETHER to minimize inductance in those leads. The same applies for the wires connecting this board to the load. This recommendation is made in order to minimize high voltage transients from occurring when the load current is shut off.

## Board Connections/Startup

The input voltage source is connected to the J1 connector, and the load is connected to the J2 connector at the OUT and GND terminals. USE TWISTED WIRES. A voltmeter should be connected to the input terminals, and one to the output terminals. The input current can be monitored with an ammeter or current probe. To monitor the status of the PGD output, connect a voltmeter from PGOOD to GND on the J2 terminal block. Put the toggle switch in the ON position.

Increase the input voltage gradually. The input current should remain less than 2 mA until the upper UVLO threshold is reached. When the threshold is reached, Q1 is turned on as described in the Theory of Operation section. If viewed on an oscilloscope, the input current increases as shown in *Figure 3* before settling at the value defined by the load. The turn-on timing depends on the input voltage, power limit setting, current limit setting, and the final load current, and is between  $\approx 3.0$  ms with no load current, and  $\approx 6.5$  ms with a 3.7A load current, with  $V_{IN} = 14V$ . See *Figures 9* and *10*.

## Circuit Parameter Changes

### CURRENT LIMIT

The current limit threshold is set by R10 according to the following equation:

$$I_{LIM} = 50 \text{ mV}/R10$$

If the load current increases such that the voltage across R10 reaches 50 mV, the LM25061 then modulates Q1's gate to limit the current to that level. This evaluation board is supplied with a 10 mohm resistor for R10, resulting in a current limit of 5A. To change the current limit threshold replace R10 with a resistor of the required value and power capability.

### POWER LIMIT

The maximum power dissipated in Q1 during turn-on, or due to a fault, is limited by R9 and R10 according to the following equation:

$$P_{FET(LIM)} = \frac{R9}{2.32 \times 10^5 \times R10}$$

With the components supplied on the evaluation board,  $P_{FET(LIM)} = 15\text{W}$ . During turn-on, when the voltage across Q1 is high, its gate is modulated to limit its drain current so the power dissipated in Q1 does not exceed 15W. As the drain-to-source voltage decreases, the drain current increases, maintaining the power dissipation constant. When the drain current reaches the current limit threshold set by R10, the current is then maintained constant until the output voltage reaches its final value. The current then decreases to a value determined by the load. See Figures 3, 9, and 10.

Each time Q1 is subjected to the maximum power limit conditions it is internally stressed for a few milliseconds. For this reason, the power limit threshold must be set lower than the limit indicated by the FET's SOA chart. In this evaluation board, the power limit threshold is set at 15W, compared to  $\approx 40\text{W}$  limit indicated in the Fairchild FDD8874 data sheet. The FET manufacturer should be contacted for more information on this subject.

### INSERTION TIME

The insertion time starts when the input voltage at VIN reaches 2.6V, and its duration is equal to

$$t_{INSERTION} = C8 \times 3.13 \times 10^5$$

During the insertion time, Q1 is held off regardless of the voltage at VIN. This delay allows ringing and transients at VIN subside before the input voltage is applied to the load via Q1. The insertion time on this evaluation board is  $\approx 213$  ms. See Figure 8.

### Fault Detection & Restart

If the load current increases to the fault level (the current limit threshold, 5A), an internal current source charges the timing capacitor at the TIMER pin. When the voltage at the TIMER pin reaches 1.72V, the fault timeout period is complete, and the LM25061 shuts off Q1. The restart sequence then begins, consisting of seven cycles at the TIMER pin between 1.72V and 1V, as shown in Figure 4. When the voltage at the TIMER pin reaches 0.3V during the eighth high-to-low ramp, Q1 is turned on. If the fault is still present, the fault timeout period and the restart sequence repeat.

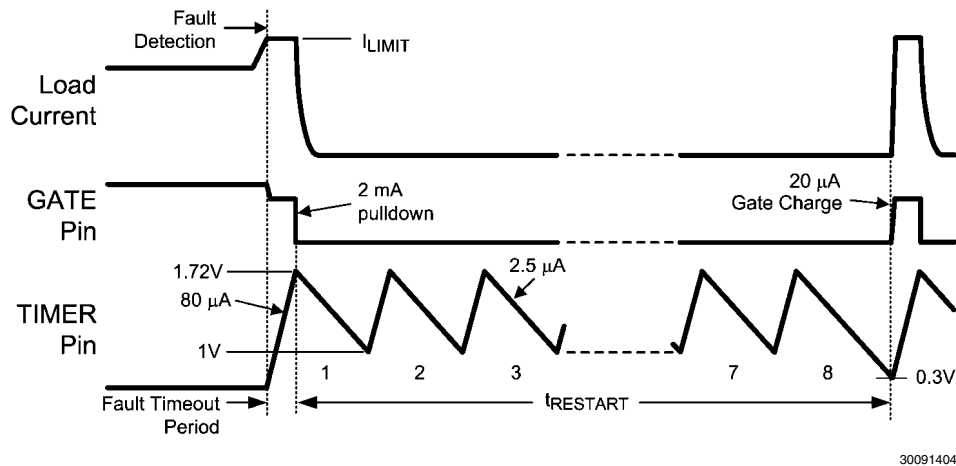

FIGURE 4. Fault Timeout and Restart Sequence

The initial fault timeout period is equal to:

$$t_{FAULT(Init)} = C_T \times 2.15 \times 10^4$$

The restart fault timeout period is equal to:

$$t_{FAULT(Restart)} = C_T \times 1.776 \times 10^4$$

The restart time is equal to:

$$t_{RESTART} = C_T \times 2.65 \times 10^6$$

The waveform at the TIMER pin can be monitored at the test pad located between C8 and R9. In this evaluation board the initial fault timeout period is 14.6 ms, the restart fault timeout period is 12.1 ms, and the restart time is 1.8 seconds. See Figures 11,12 and 13.

## UVLO Input Voltage Threshold

Programming the UVLO thresholds sets the minimum system voltage to enable the series pass device (Q1). If  $V_{SYS}$  is below the UVLO thresholds, Q1 is switched off, denying power to the load. Programmable hysteresis is provided.

### OPTION A

The UVLO thresholds are set with two resistors (R1, R2) as shown in Figure 5.

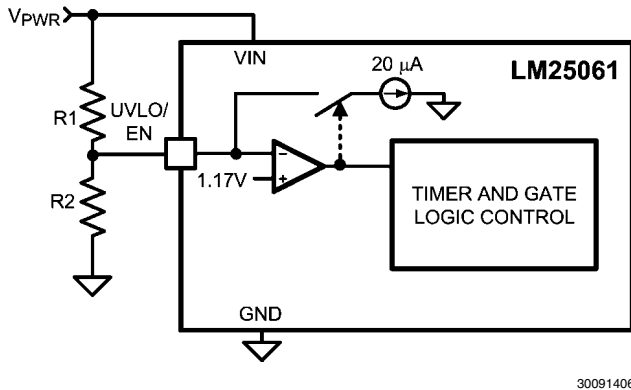

FIGURE 5. Programming the UVLO Threshold

The two resistor values are calculated as follows:

- Choose the upper and lower UVLO thresholds ( $V_{UVH}$ ) and ( $V_{UVL}$ ).

$$R1 = \frac{V_{UVH} - V_{UVL}}{20 \mu A} = \frac{V_{UV(HYS)}}{20 \mu A}$$

$$R2 = \frac{1.17V \times R1}{V_{UVL} - 1.17V}$$

Where the resistor values are known, the threshold voltages and hysteresis are calculated from the following:

$$V_{UVH} = 1.17V + [R1 \times \frac{(1.17V + 20 \mu A)}{R2}]$$

$$V_{UVL} = \frac{1.17V \times (R1 + R2)}{R2}$$

$$V_{UV(HYS)} = R1 \times 20 \mu A$$

### OPTION B

The minimum UVLO level is obtained by connecting the UVLO pin to VIN as shown in Figure 6. On this evaluation board the UVLO pin is accessible at the TP1 test point located to the right of the toggle switch. Q1 is switched on when the VIN voltage reaches the POR threshold ( $\approx 2.6V$ ).

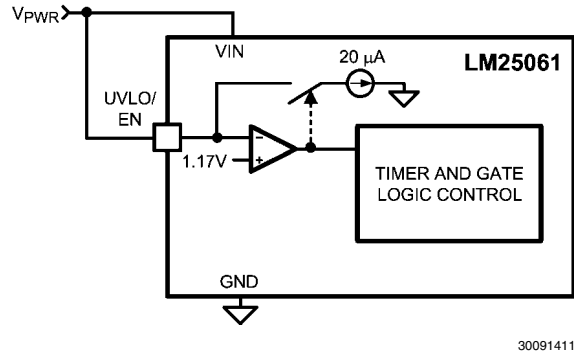

FIGURE 6. UVLO = POR

## Shutdown

With the circuit in normal operation, the LM25061 can be shutdown by grounding the UVLO pin. Test point TP1, located to the right of the toggle switch, can be used for this purpose.

## POWER GOOD and FB Pins

During turn-on, the Power Good pin (PGD) is high until the voltage at VIN increases above  $\approx 1.6V$ . PGD then switches low, remaining low as the input voltage increases. When the voltage at the board's output pin increases above 13V PGD switches high. PGD switches low when the output voltage decreases below 12.5V. Additionally, PGD switches low if the UVLO pin is taken below its threshold regardless of the output voltage.

The output voltage threshold for the PGD pin is set with two resistors (R3, R4) at the FB pin as shown in Figure 7.

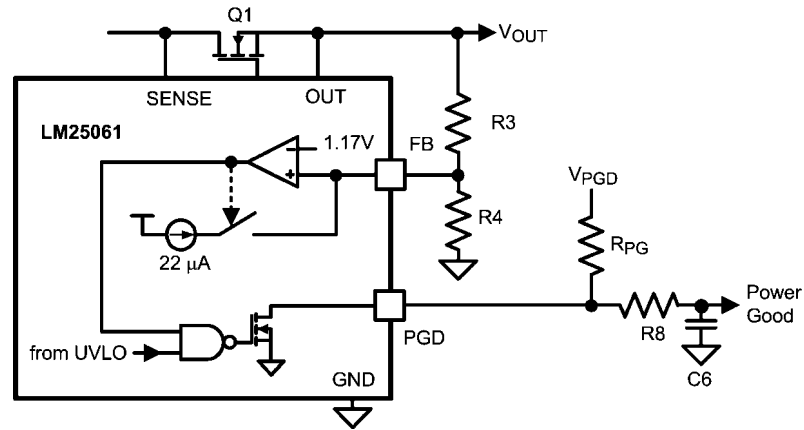

30091416

**FIGURE 7. Programming the PGD Threshold**

The resistor values are calculated as follows:

- Choose the upper and lower threshold ( $V_{PGDH}$ ) and ( $V_{PGDL}$ ) at  $V_{OUT}$ .

$$R3 = \frac{V_{PGDH} - V_{PGDL}}{22 \mu A} = \frac{V_{PGD(HYS)}}{22 \mu A}$$

$$R4 = \frac{1.17V \times R3}{(V_{PGDH} - 1.17V)}$$

Where the R3 and R4 resistor values are known, the threshold voltages and hysteresis are calculated from the following:

$$V_{PGDH} = \frac{1.17V \times (R3 + R4)}{R4}$$

$$V_{PGDL} = 1.17V + [R3 \times \frac{(1.17V - 22 \mu A)}{R4}]$$

$$V_{PGD(HYS)} = R3 \times 22 \mu A$$

A pull-up voltage and pull-up resistor are required at PGD as shown in Figure 7. The pull-up voltage ( $V_{PGD}$ ) can be as high as 17V, with transient capability to 20V, and can be higher or lower than the voltages at  $V_{IN}$  and  $V_{OUT}$ . This EVB is supplied with pins 1-2 jumpered on JMP2, powering the PGD pin from the input voltage through a 100 k $\Omega$  pull-up resistor. To change the high level PGD voltage, move the jumper on JMP2 to pins 2-3, and supply the appropriate pull-up voltage to terminal P1 (located next to JMP2). If a delay at the PGD output is desired, a resistor and capacitor can be added at positions R8 and C6.

### LM25061-1 Latch Version

The LM25061-2 supplied on this evaluation board provides a restart attempt after a fault detection, as described above. The companion Hot-Swap IC, the LM25061-1, latches off after a fault detection, with external control required for restart. Restart is accomplished by momentarily taking the UVLO pin below its threshold, or by removing and re-applying the input voltage at  $V_{IN}$ . Contact the nearest National Semiconductor sales office to obtain samples of the LM25061-1.

## Performance Characteristics

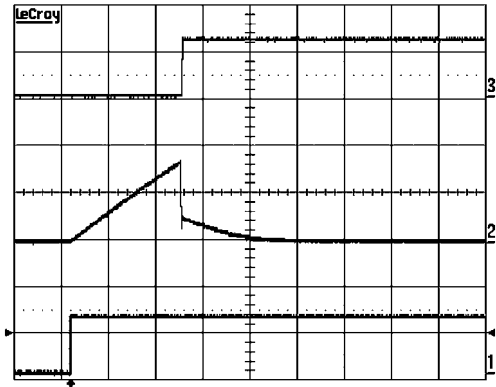

30091417

Horizontal Resolution: 100 ms/div  
 Trace 1:  $V_{IN}$ , 10V/div  
 Trace 2: TIMER Pin, 1V/div  
 Trace 3:  $V_{OUT}$ , 10V/div  
 $V_{IN} = 12V$ ,  $C_T = 0.68 \mu F$

**FIGURE 8. Insertion Time Delay**

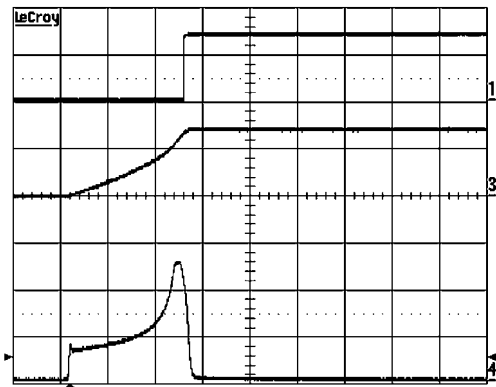

30091418

Horizontal Resolution: 1 ms/div  
 Trace 1: PGD Pin, 10V/div  
 Trace 2: TIMER Pin, 1V/div  
 Trace 3:  $V_{OUT}$ , 10V/div  
 Trace 4: Input Current, 2A/div  
 $V_{IN} = 14V$ , Load = 1 k $\Omega$

**FIGURE 9. Turn-On Sequence with Minimal Load Current**

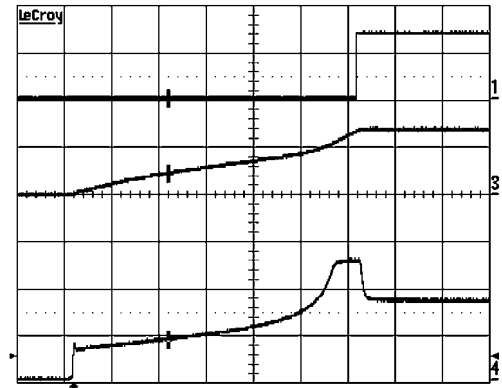

30091419

Horizontal Resolution: 1 ms/div  
 Trace 1: PGD Pin, 10V/div  
 Trace 3:  $V_{OUT}$ , 10V/div  
 Trace 4: Input Current, 2A/div  
 $V_{IN} = 14V$ , Load = 4 $\Omega$

**FIGURE 10. Turn-On Sequence into a 4 $\Omega$  Load**

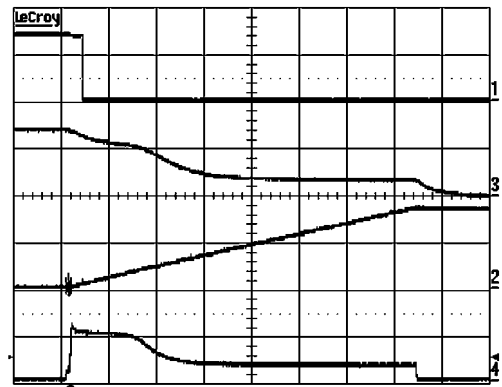

30091420

Horizontal Resolution: 2 ms/div  
 Trace 1: PGD Pin, 10V/div  
 Trace 2: TIMER Pin, 1V/div  
 Trace 3:  $V_{OUT}$ , 10V/div  
 Trace 4: Input Current, 5A/div  
 $V_{IN} = 14V$ , Load Switched from 1 k $\Omega$  to 2 $\Omega$   
 $C_T = 0.68 \mu F$

**FIGURE 11. Initial Fault Timeout**

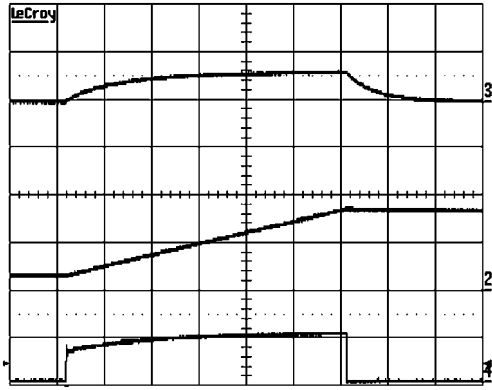

30091421

Horizontal Resolution: 2 ms/div  
 Trace 2: TIMER Pin, 1V/div  
 Trace 3:  $V_{OUT}$ , 10V/div  
 Trace 4: Input Current, 2A/div  
 $V_{IN} = 14V$ , Load =  $3\Omega$ ,  $C_T = 0.68 \mu F$

**FIGURE 12. Restart Fault Timeout**

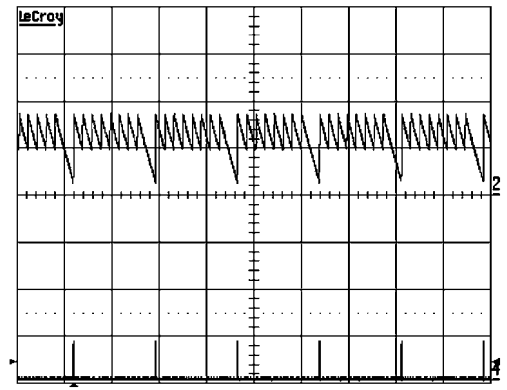

30091422

Horizontal Resolution: 1sec/div  
 Trace 2: TIMER Pin, 1V/div  
 Trace 4: Input Current, 2A/div  
 $V_{IN} = 14V$ , Load =  $2\Omega$ ,  $C_T = 0.68 \mu F$

**FIGURE 13. Restart Timing**



## Bill of Materials

Item	Description	Mfg., Part No.	Package	Value
C1	Ceramic Capacitor	TDK C2012X7R2A102M	0805	1000 pF, 100V
C3, C4	Alum. Elec. Capacitor	Panasonic EEE-TG1V221UP	Surf. Mount	220 $\mu$ F, 35V
C5	Ceramic Capacitor	TDK C3216X7R2A104M	1206	0.1 $\mu$ F, 100V
C6	Unpopulated			
C7	Alum. Elec. Capacitor	Panasonic EEE-TG1V101P	Surf. Mount	100 $\mu$ F, 35V
C8	Ceramic Capacitor	MuRata GRM188R61A684KA61D or Panasonic ECJ-2FB1A684K	0805	0.68 $\mu$ F, 10V or higher
Q1	MOSFET	Fairchild FDD8874	TO-252	
R1	Resistor	Vishay CRCW120614K0F	1206	14k
R2	Resistor	Vishay CRCW08054K99F	0805	4.99k
R3	Resistor	Vishay CRCW080523K2F	0805	23.2k
R4	Resistor	Vishay CRCW08052K26F	0805	2.26k
R7	Resistor	Vishay CRCW1206100KF	1206	100k, $\frac{1}{4}$ W
R8	Resistor	Vishay CRCW08050000Z	0805	Zero ohm jumper
R9	Resistor	Vishay CRCW080534K8F	0805	34.8k
R10	Resistor	Vishay WSL2010R0100F	2010	0.010 ohm, $\frac{1}{2}$ W
SW1	Toggle Switch	NKK M2012SS1W03-RO		SPDT switch, 6A
U2	Hot Swap IC	Nat'l Semi LM25061MM-2	MSOP-10	
Z1	Trans. Suppressor	Diodes Inc. SMBJ16A	SMB	16V

# PC Board Layout

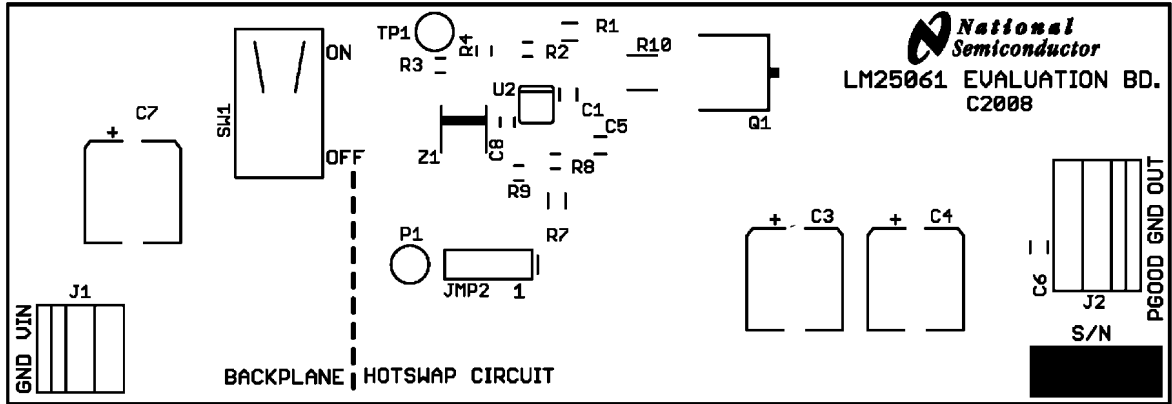

Board Silkscreen

30091424

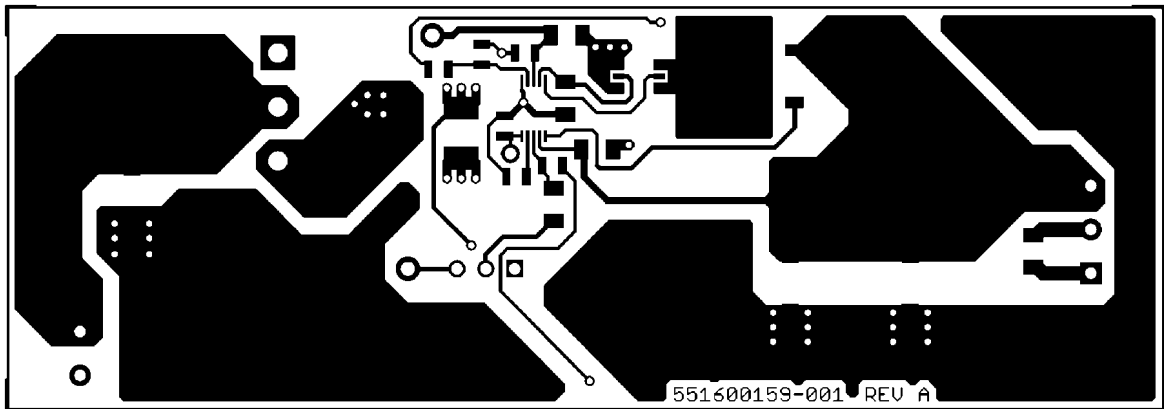

Board Top Layer

30091425

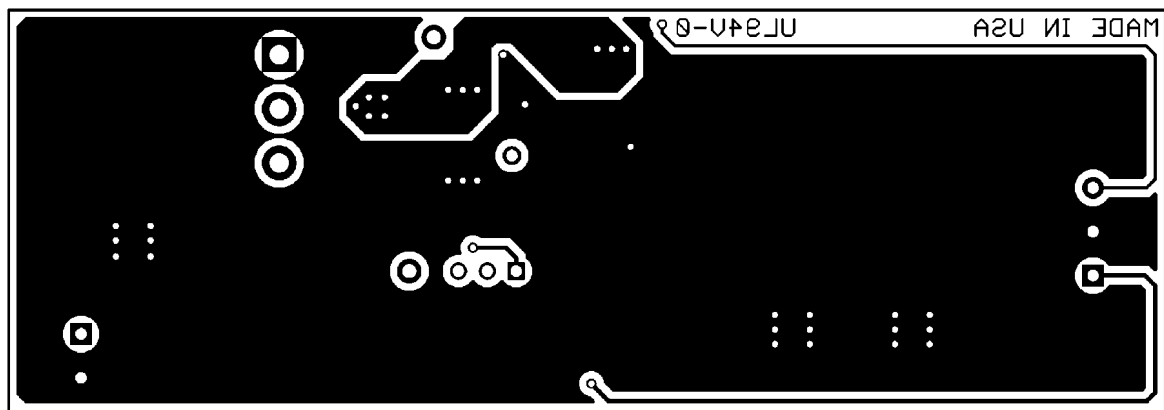

Board Bottom Layer (viewed from top)

30091426

# Notes

AN-1946

## Notes

For more National Semiconductor product information and proven design tools, visit the following Web sites at:

Products		Design Support	
Amplifiers	<a href="http://www.national.com/amplifiers">www.national.com/amplifiers</a>	WEBENCH® Tools	<a href="http://www.national.com/webench">www.national.com/webench</a>
Audio	<a href="http://www.national.com/audio">www.national.com/audio</a>	App Notes	<a href="http://www.national.com/appnotes">www.national.com/appnotes</a>
Clock and Timing	<a href="http://www.national.com/timing">www.national.com/timing</a>	Reference Designs	<a href="http://www.national.com/refdesigns">www.national.com/refdesigns</a>
Data Converters	<a href="http://www.national.com/adc">www.national.com/adc</a>	Samples	<a href="http://www.national.com/samples">www.national.com/samples</a>
Interface	<a href="http://www.national.com/interface">www.national.com/interface</a>	Eval Boards	<a href="http://www.national.com/evalboards">www.national.com/evalboards</a>
LVDS	<a href="http://www.national.com/lvds">www.national.com/lvds</a>	Packaging	<a href="http://www.national.com/packaging">www.national.com/packaging</a>
Power Management	<a href="http://www.national.com/power">www.national.com/power</a>	Green Compliance	<a href="http://www.national.com/quality/green">www.national.com/quality/green</a>
Switching Regulators	<a href="http://www.national.com/switchers">www.national.com/switchers</a>	Distributors	<a href="http://www.national.com/contacts">www.national.com/contacts</a>
LDOs	<a href="http://www.national.com/ldo">www.national.com/ldo</a>	Quality and Reliability	<a href="http://www.national.com/quality">www.national.com/quality</a>
LED Lighting	<a href="http://www.national.com/led">www.national.com/led</a>	Feedback/Support	<a href="http://www.national.com/feedback">www.national.com/feedback</a>
Voltage Reference	<a href="http://www.national.com/vref">www.national.com/vref</a>	Design Made Easy	<a href="http://www.national.com/easy">www.national.com/easy</a>
PowerWise® Solutions	<a href="http://www.national.com/powerwise">www.national.com/powerwise</a>	Solutions	<a href="http://www.national.com/solutions">www.national.com/solutions</a>
Serial Digital Interface (SDI)	<a href="http://www.national.com/sdi">www.national.com/sdi</a>	Mil/Aero	<a href="http://www.national.com/milaero">www.national.com/milaero</a>
Temperature Sensors	<a href="http://www.national.com/tempensors">www.national.com/tempensors</a>	SolarMagic™	<a href="http://www.national.com/solarmagic">www.national.com/solarmagic</a>
Wireless (PLL/VCO)	<a href="http://www.national.com/wireless">www.national.com/wireless</a>	PowerWise® Design University	<a href="http://www.national.com/training">www.national.com/training</a>

THE CONTENTS OF THIS DOCUMENT ARE PROVIDED IN CONNECTION WITH NATIONAL SEMICONDUCTOR CORPORATION ("NATIONAL") PRODUCTS. NATIONAL MAKES NO REPRESENTATIONS OR WARRANTIES WITH RESPECT TO THE ACCURACY OR COMPLETENESS OF THE CONTENTS OF THIS PUBLICATION AND RESERVES THE RIGHT TO MAKE CHANGES TO SPECIFICATIONS AND PRODUCT DESCRIPTIONS AT ANY TIME WITHOUT NOTICE. NO LICENSE, WHETHER EXPRESS, IMPLIED, ARISING BY ESTOPPEL OR OTHERWISE, TO ANY INTELLECTUAL PROPERTY RIGHTS IS GRANTED BY THIS DOCUMENT.

TESTING AND OTHER QUALITY CONTROLS ARE USED TO THE EXTENT NATIONAL DEEMS NECESSARY TO SUPPORT NATIONAL'S PRODUCT WARRANTY. EXCEPT WHERE MANDATED BY GOVERNMENT REQUIREMENTS, TESTING OF ALL PARAMETERS OF EACH PRODUCT IS NOT NECESSARILY PERFORMED. NATIONAL ASSUMES NO LIABILITY FOR APPLICATIONS ASSISTANCE OR BUYER PRODUCT DESIGN. BUYERS ARE RESPONSIBLE FOR THEIR PRODUCTS AND APPLICATIONS USING NATIONAL COMPONENTS. PRIOR TO USING OR DISTRIBUTING ANY PRODUCTS THAT INCLUDE NATIONAL COMPONENTS, BUYERS SHOULD PROVIDE ADEQUATE DESIGN, TESTING AND OPERATING SAFEGUARDS.

EXCEPT AS PROVIDED IN NATIONAL'S TERMS AND CONDITIONS OF SALE FOR SUCH PRODUCTS, NATIONAL ASSUMES NO LIABILITY WHATSOEVER, AND NATIONAL DISCLAIMS ANY EXPRESS OR IMPLIED WARRANTY RELATING TO THE SALE AND/OR USE OF NATIONAL PRODUCTS INCLUDING LIABILITY OR WARRANTIES RELATING TO FITNESS FOR A PARTICULAR PURPOSE, MERCHANTABILITY, OR INFRINGEMENT OF ANY PATENT, COPYRIGHT OR OTHER INTELLECTUAL PROPERTY RIGHT.

#### LIFE SUPPORT POLICY

**NATIONAL'S PRODUCTS ARE NOT AUTHORIZED FOR USE AS CRITICAL COMPONENTS IN LIFE SUPPORT DEVICES OR SYSTEMS WITHOUT THE EXPRESS PRIOR WRITTEN APPROVAL OF THE CHIEF EXECUTIVE OFFICER AND GENERAL COUNSEL OF NATIONAL SEMICONDUCTOR CORPORATION.** As used herein:

Life support devices or systems are devices which (a) are intended for surgical implant into the body, or (b) support or sustain life and whose failure to perform when properly used in accordance with instructions for use provided in the labeling can be reasonably expected to result in a significant injury to the user. A critical component is any component in a life support device or system whose failure to perform can be reasonably expected to cause the failure of the life support device or system or to affect its safety or effectiveness.

National Semiconductor and the National Semiconductor logo are registered trademarks of National Semiconductor Corporation. All other brand or product names may be trademarks or registered trademarks of their respective holders.

Copyright© 2009 National Semiconductor Corporation

For the most current product information visit us at [www.national.com](http://www.national.com)



**National Semiconductor  
Americas Technical  
Support Center**  
Email: [support@nsc.com](mailto:support@nsc.com)  
Tel: 1-800-272-9959

**National Semiconductor Europe  
Technical Support Center**  
Email: [europe.support@nsc.com](mailto:europe.support@nsc.com)

**National Semiconductor Asia  
Pacific Technical Support Center**  
Email: [ap.support@nsc.com](mailto:ap.support@nsc.com)

**National Semiconductor Japan  
Technical Support Center**  
Email: [jpn.feedback@nsc.com](mailto:jpn.feedback@nsc.com)