

POEPHYTEREV-I / -E User Guide

National Semiconductor
Application Note 1521
Youhao Xi Bradley Kennedy
April 4, 2008



Introduction

The POEPHYTEREV-I/-E evaluation board is a seamless design demonstrating National's LM5072 PoE product (capable of up to 24W) and DP83848I (single port 10/100Mb/s) Ethernet PHYTER® product. While both the LM5072 and the DP83848 Ethernet PHY device have many advanced and enticing features, this specific board is designed to demonstrate a subset of those features, specifically Power over Ethernet. Two versions of this board are available. The -I version has an RJ-45 connector that with integrated Ethernet magnetics. The -E version has discrete RJ-45 connector and Ethernet magnetics. The schematics of the board are available with this kit for duplication into an end application product.

For additional features of the PoE and PHY devices, individual device evaluation boards are separately available. For detailed information about the complete functions and features of the LM5072 or DP83848 devices, refer to the relevant datasheets. For applications where IEEE 802.3af must be complied with and the power level is below 12.95W, refer to Application Note AN-1455 (www.national.com/an/AN/AN-1455.pdf). For detailed information about the Ethernet PHYTER® circuit, refer to Application Note AN-1469 (www.national.com/an/AN/AN-1469.pdf).

This evaluation kit contains:

- POEPHYTEREV-I or -E Evaluation board
- Printed copy of this User's Guide
- Board schematic
- End User Licensing Agreement (EULA)

Scope of Applications

The POEPHYTEREV-I/-E evaluation kit (EK) is designed for high power PD (PoE terminology - Powered Device) applications in which the maximum power exceeds the IEEE 802.3af's 12.95W limit. The evaluation board features National's DP83848 10/100 Mb/s PHYTER® Ethernet Physical Layer Transceiver, so any equipment that provides a standard IEEE 802.3, Clause 22 MII DTE interface; e.g. SmartBits/Netcom box, is required as a data source for the Ethernet device. The LM5072 is a 100V, high power PoE PD and PWM controller. The evaluation board is capable of operating with both PoE and auxiliary (AUX) power sources. The dc-dc converter stage of the power supply is implemented in the versatile flyback converter topology.

Important Note on Circuit Board

Versions

There are two versions of PCBs being built, which can be identified by the PCB serial number printed along the left edge of the top side the circuit board. One version is labelled 551012916-001 Rev A, the other 551013040-001 Rev A. The first version cannot modify the 3.3V output to higher voltages because it is directly connected to the PHY through inner layers. It is modified on the second version such that higher output voltage can be produced without damaging the PHY circuit. The factory default output setting for both versions is

3.3V. Contact National on support to modify the latter version to other output voltage.

In the following, descriptions apply to both versions of the circuit boards unless specifically indicated.

Features of the Evaluation Board

Seamless design solution, incorporating DP83848 PHYTER® single port 10/100 Mb/s Ethernet physical layer transceiver and LM5072 High Power PoE PD and PWM controller.

Ethernet

- Integrated or External magnetics and RJ45
- Minimum configuration requirements:
 - 2 PHY Addresses - 01h (default) or 03h
 - Status LEDs – board power, others dependant on LED mode selected
 - Limited Strap Options – MDIX_EN, LED_CFG, PWR_DWN/INT, MII/RMII Sel
 - RESET_N jumper
 - PWR_DWN/INT jumper
- Connections for the following interfaces:
 - MII/RMII Interface (IEEE 802.3 standard)
 - RJ-45 Cat-V Ethernet cable connector
 - JTAG header
 - 25MHz_OUT header
 - Header for "ribbon cable" connection to MII/RMII
- On-board clock – Crystal/Oscillator Dual Footprint

Power Over Ethernet

- Isolated output voltage: 3.3V
- Maximum output current: 7.3A
- Maximum output power: 24W
- Input voltage ranges:
 - PoE input voltage range: 39 to 57V
 - AUX input voltage range: 22 to 57V
- Measured maximum efficiency:
 - DC to DC converter efficiency: 90% at 6A
 - Overall efficiency (including the input diode bridge): 86% at 6A
- Overall Board Size: 5.50" x 3.96" x 0.70"
- Switching frequency: 250 kHz
- Optional input common-mode filter

PCB Layout Considerations

- FR4 material
- Trace symmetry within differential pair ($\pm 0.5^\circ$)
- Differential impedance 100 ohms, $\pm 5\%$
- Adjacent differential pairs spacing $> 2X$ distance within a differential pair, to minimize cross-talk and EMI
- Trace length matching between differential pairs not required
- Uniform supply & ground plane
- Void planes under magnetics, except for Chassis GND (at RJ-45 edge only)
- Combination of through-hole and surface mount technology
- Trace/space will be 0.007"/0.008" minimum

- System interface will be via the MII connector, and MII header
- RJ-45 for network connection
- JTAG access via 2x5 header

Usage setup and Configuration

This section contains information about the setup and configuration of the POEPHYTEREV-I/-E evaluation board, including descriptions of the card's interfaces, connectors, jumpers and LEDs.

Power for the POEPHYTEREV board can be supplied by a number of means:

- MII connector J1
- PoE over unused pairs
- PoE over data pairs
- External supply to P1
- If 5V is supplied from the MII connector, the on-board voltage regulator, U2, will convert 5V to 3.3V for the PHYTER®. J7 should be removed.

- If 3.3V is supplied from the MII connector, J7 needs to be ON (See schematics for details).
- Only applies to the circuit board version with PCB serial number 551013040-001 Rev A: J7 should be shorted if the PoE main output is set at 3.3V, which is the default factory setting. To modify the output to other higher voltages, a 3.3V LDO should be installed onto U2 and J7 must be open.

Address Settings:

The PMD address for the DP83848 Physical Layer device is set by jumper J3.

- Default board setting for the PHY Address is 01h
- The board may be set to PHY Address 03h by adding jumper J3

Table of Jumpers

Jumper	Name	Function
J1	MII Male Connector	MII interface
J2	MII Header	Alternative connection for MII signals
J3	PHYAD1	PHY Address strap pin
J4	MDIX_EN	Enable/Disable MDIX mode. (Default is Auto-MDIX Enable)
J5	LED_CFG	Set LED configuration. See datasheet
J6(Not populated)		
J7	MII 3V3 option	Use 3V3 MII supply
J8	PWR_DWN/INT	Set Power Down and Interrupt Mode. See datasheet
J9	RESET_N	Reset the device
J10 (Not populated)		
J11 (Not populated)		
J12	Pulse Jack	Integrated Magnetic RJ-45 connector

Additional information for all options above may be found in the DP83848 datasheet.

Status indicators: LEDs

The POEPHYTEREV board supplies numerous status indicators via LEDs.

Status provided include:

Link - DS3*

Media Speed - DS2

Activity/Collision - DS4*

Ethernet Device Power - DS1

PoE Power - LED1

*Other status can be indicated by these LEDs. The alternate status is set by adding jumper J5. Refer the DP83848 datasheet for additional information.

Ethernet Performance

The DP83848 PHYTER® supports line speed Ethernet network communications. Signal quality, which affects IEEE compliance, can vary depending on board layout, power supplies, and components used, esp. isolation magnetics.

Software

No device specific software is required for this board National does provide the integrity utility; a diagnostic and configuration package at:

www.national.com/appinfo/networks/ethernet_utility.html

An Important Note About the Maximum Power Capability and Cable Usage

The maximum output power is 24W. The user must make sure that the Power Sourcing Equipment (PSE) in use can provide at least 30W.

Important: Please note that the CAT-5 cable may not support the said power over two pairs of twisted wires under strict safety considerations. Users shall select the proper cable wires to support the design power level without compromising the applicable safety standards. Using an improper cable at such power levels may violate safety regulations and may cause damage.

A Note about PoE Input Potentials

PoE applications are typically -48V systems, in which the notations GND and -48V normally refer to the high and low input potentials, respectively. However, for easy readability, the LM5072 datasheet was written in the positive voltage convention with positive input potentials referenced to the VEE pin of the LM5072. Therefore, when testing the evaluation board with a bench power supply, the negative terminal of the power supply is equivalent to the PoE system's -8V potential, and the positive terminal is equivalent to the PoE system ground. To prevent confusion between the datasheet and this application note, the same positive voltage convention is used herein.

Schematics of the Evaluation Board

Figure 1, Figure 2 and Figure 3 shows the schematic of the evaluation board.

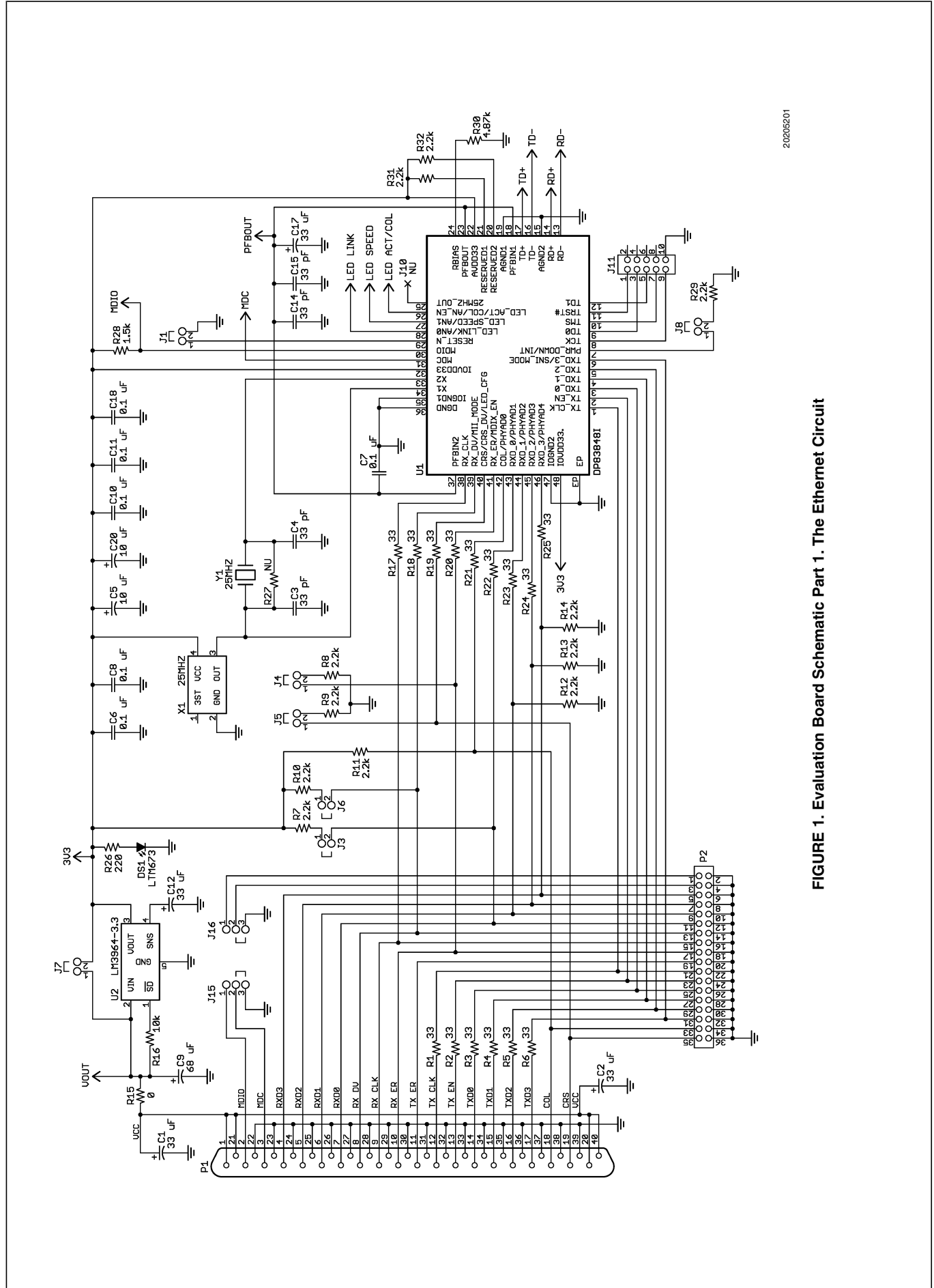
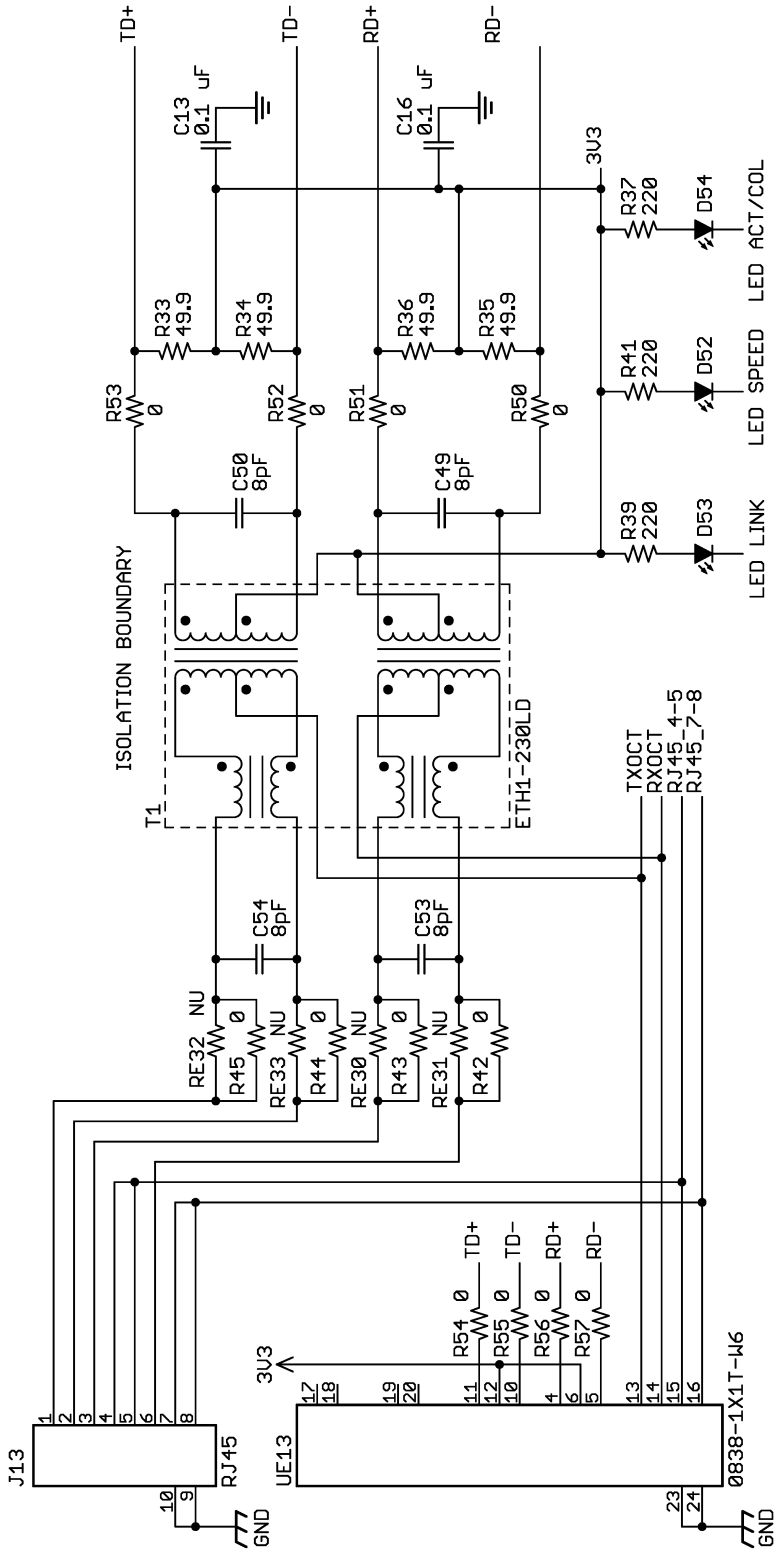

FIGURE 1. Evaluation Board Schematic Part 1. The Ethernet Circuit

20205201



20205212

FIGURE 2. Evaluation Board Schematic Part 2: RJ45 connectors and Ethernet Magnetics

Connection and Proper Test Methods

Figure 4 shows a photo of the evaluation board with the connection ports indicated. The PoE circuit occupies the lower part of the board within the rectangular outline. The RJ45 connectors, Ethernet magnetics and PHY circuit are placed in the upper area of the board.

The following are the seven connections:

- **J1**, a 42 pin MII Connector for the Ethernet media independent interface.
- **JE4 through JE7**, double pairs of connection pins for the 3.3V output. JE4 and JE5 are the high potential pins

- **J13**, a regular RJ45 connector on the -E version board for PoE input and data link
- **UE13**, Bel Stewart Integrated RJ45 connector on the -I version board for PoE input and data link
- **TP7 and TP8**, a pair of pins for quick PoE input connection to a bench power supply. TP7 is the high potential pin
- **P1**, a PJ102A power jack, for Auxiliary (AUX) power input. The center pin of P1 is the high potential pin
- **TP3 and TP4**, a pair of pins for quick AUX power input connection to a bench power supply. TP3 is the high potential pin

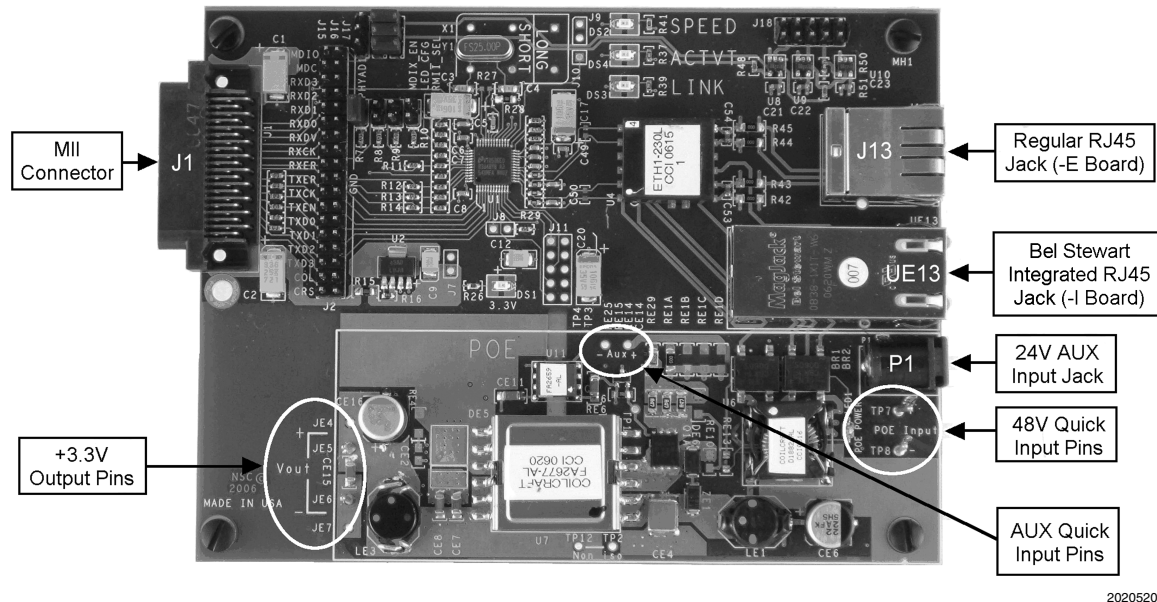

20205202

FIGURE 4. The Connection Ports of the Evaluation Board

The -E version evaluation board employs a regular RJ45 connector, J13, which is to be used with the external Ethernet magnetics assembly U4. The -I version evaluation board uses an integrated RJ45 connector, UE13, which has the Ethernet magnetics enclosed in the case.

For the PoE input through either RJ45 connector, the diode bridge BR1 or BR2 is used to steer the current to the positive and negative supply pins of the LM5072, namely the VIN and VEE pins. When using TP7 and TP8 for the quick PoE input connection to a bench power supply, make sure TP7 is the high potential terminal.

For the AUX power input, the higher potential should feed into the center pin of P1. When using TP3 and TP4 for the quick AUX input connection to a bench power supply, be aware that TP3 is the high potential pin. The diode DE1 provides the reverse protection of the AUX input.

Please note that TP4 and TP8 are two different return pins for the PoE and AUX inputs, respectively. They are not connected to the same circuit node, and they should not be interchanged.

For the output connection, the load can be either a passive resistor or active electronic load. Attention should be paid to the output polarity when connecting an electronic load. It is not recommended to use additional filter capacitors greater than 20 μF total across the output port as the extra capaci-

tance will alter the feedback loop properties and may cause instability. If it is necessary to add extra capacitance in a particular application, the feedback loop compensation must be adjusted accordingly.

Sufficiently large wire such as AWG #18 or thicker is required when connecting the source supply and load. Also, monitor the current into and out of the circuit board. Monitor the voltages directly at the board terminals, as resistive voltage drops along the connecting wires may decrease measurement accuracy. Never rely on the bench supply's voltmeter or ammeter if accurate efficiency measurements are desired.

When measuring the dc-dc converter efficiency, the converter input voltage should be measured across CE4. When measuring the evaluation board overall efficiency (which is more relevant), both input and output voltages should be read from the terminals of the evaluation board. Remember to count the power dissipation by the PHY circuit in the efficiency measurement. When the PHY circuit is in the idle mode, it will draw 55 mA from the 3.3V rail, most of which is consumed by the on-board LED indicators.

Refer to the appropriate user manual or instruction for the use of the MII connector.

Source Power

To fully test the evaluation board, either a high power PSE able to supply 30W or a lab bench DC power supply capable of at least 60V and 1A is required for the PoE input. For the AUX source power, use a 24V AC adapter or a DC power supply capable of 30V and 3A. Use the output over-voltage and over-current limit features of the bench power supplies to protect the board against damage by errant connections.

Loading/Current Limiting Behavior

A resistive load is optimal, but an appropriate electronic load specified for operation down to 2.0V is acceptable. The maximum load current is 7.3A. Exceeding this current at low input voltage may cause oscillatory behavior as the circuit will go into current limit mode. Exceeding this current at high input voltage may force the DC-DC converter to run into cycle by cycle peak current limit. Current limit mode is triggered whenever the average current through the PoE connector exceeds 800 mA (setting is determined by RE23, see the LM5072 datasheet for details). The circuit then runs into a retry mode (hiccup). Cycle-by-cycle peak current limit mode narrows the duty cycle and hence the output voltage loses regulation and enters an under voltage condition. In both current limit modes, the circuit will not be latched off and normal operation will be automatically restored after the removal of the fault condition.

Power Up

For the first time power up, it is recommended to apply PoE power first. The load should be kept reasonably low (under 25% of full load). Check the supply current during signature detection and classification modes before applying full power. During detection mode, the module should have the I-V characteristics of a 25 k Ω resistor in series with two diodes. During classification mode, the current draw should be about 40 mA at 16V, which is determined by RE22 of 31.6 Ω . This sets the evaluation board to Class 4, which is “reserved for future use” per IEEE 802.3af, namely the high power application. If the proper response is not observed during both detection and classification modes, check the connections closely. If no current is flowing it is likely that the set of conductors feeding PoE power have been incorrectly installed. Once the proper setup has been established, full power can be applied. A voltmeter across the output terminals JE5 (3.3V) and JE6 (3.3V RTN) will allow direct measurement of the 3.3V output line. If the 3.3V output voltage is not observed within a few seconds, turn off the power supply and review connections. A final check of efficiency is the best way to confirm that the circuit is operating properly. Efficiency being significantly lower than 80% at full load indicates a problem.

After proper PoE operation is verified, the user may apply AUX power. It is recommended that the application of AUX power follow the same precautions as those for PoE power application. If no output voltage is observed, it is likely that the AUX power feed polarity is reversed. After successful operation is observed, full AUX power testing can begin.

PD Interface Operating Modes

When connecting into the PoE system, the evaluation board will go through the following operating modes in sequence: PD signature detection, power level classification (optional), and application of full power. See the LM5072 datasheet for details.

Signature Detection

The 25 k Ω PD signature resistor is integrated into the LM5072 IC. The PD signature capacitor is realized by CE29, a 100 nF capacitor. During AUX power operation, CE29 also improves the noise immunity of the IC substrate (interconnected to the VEE pin) by providing a low impedance path to the COM node.

It should be noted that when AUX power is applied first, it will not allow the PSE to identify the PD as a valid device because the AUX voltage will cause the current steering diode bridges BR1 and BR2 to be reverse biased during detection mode. This prevents the PSE from applying power, so the evaluation board will only draw current from the AUX source.

Classification

PD classification is implemented with RE22. The evaluation board is preset to Class 4 by installing a resistor of 31.6 Ω at RE22, indicating that the power consumption of the evaluation board exceeds the 12.95W limit per IEEE 802.3af.

Input UVLO and UVLO Hysteresis

The input Under Voltage Lock-Out (UVLO) is an integrated function of the LM5072. The UVLO release threshold is set to approximately 38.5V (at the pins of the IC) and the UVLO hysteresis is approximately 7V.

Inrush and DC Current Limit Programming

The LM5072 allows the user to independently program the inrush and DC current limits of the internal hot swap MOSFET. The evaluation board sets the inrush limit to the default 150 mA by leaving RE19 unpopulated, and the DC current limit to 800 mA by installing a 15.8 k Ω resistor at RE23. To adjust the inrush and DC current limits, use proper resistors for RE19 and RE23, respectively, according to the recommendations in the LM5072 datasheet.

Auxiliary Power Option

In this evaluation board, the AUX power is configured into the AUX dominant mode. Please refer to the LM5072 datasheet for details.

During AUX dominance, the AUX power source will always supply the current to the PD regardless whether the PoE power is present or not. Note that auxiliary non-dominance does not imply PoE dominance. To achieve PoE dominance, additional circuitry must be employed. Contact National Semiconductor for a schematic of a robust PoE dominant solution.

Because the AUX input bypasses the LM5072's input hot swap circuit, the evaluation board uses eight 8.06 Ω resistors (RE1A through RE1D and RE2A through RE2D) in parallel to achieve a low cost AUX inrush limiter and transient protection. Otherwise the unlimited inrush currents can wear on-board traces, connector contacts, and various board components, as well as create damaging transient voltages. Nevertheless, these eight resistors will cause power loss in the AUX power mode, and they also reduce the effective AUX input voltage level sensed by the VIN pin of the LM5072. A more efficient and generally better performing AUX inrush limiter can be achieved with additional circuitry employing a bipolar transistor or MOSFET. Contact National Semiconductor for support.

If the AUX power option is not used in a new design, delete CE3, DE1, the eight resistors RE1A through RE1D and RE2A through RE2D, RE13, RE29, and P1 to lower the BOM cost.

AUX Input “OR-ing” Diode Selection

This diode does not need to be a high speed type since there is no switching action during operation, however, it should be a low reverse leakage current device. RE29, a 24.9 k Ω resistor is employed on the evaluation board, providing a sinking path for the leakage current of DE1. It is meant to sink all of the leakage current of DE1 and prevent a false logic state at the RAUX pin. Please see the LM5072 datasheet for more details about the selection of DE1 and RE29.

Flyback Converter Topology

The dc-dc converter stage of the evaluation board features the flyback topology, which employs the minimum number of power components to implement an isolated power supply at the lowest possible cost. Generally, the flyback topology is best suited for applications of power levels lower than 50W. When the power level is higher, the forward, push-pull and bridge topologies will be appropriate candidates.

A unique characteristic of the flyback topology is its power transformer. Unlike an ordinary power transformer that simultaneously transfers the power from the primary to the secondary, the flyback transformer first stores the energy inside the transformer while the main switch is turned on, and then releases the stored energy to the load during the rest of the cycle. When the stored energy is not completely released before the main switch is turned on again, it is said that the flyback converter operates in continuous conduction mode (CCM). Otherwise, it is in discontinuous conduction mode (DCM).

Major advantages of CCM over DCM include (i) lower ripple current and ripple voltage, resulting in smaller input and output filter capacitors; and (ii) lower RMS current, thus reducing the conduction losses. To keep the flyback converter in CCM at light load, the transformer's primary inductance should be designed as large as is practical.

Major drawbacks of CCM, as compared to DCM, are (i) the presence of the right-half-plane zero, which may limit the achievable bandwidth of the feedback loop, and (ii) the need for slope compensation to stabilize the feedback loop at duty cycles greater than 50%.

The flyback topology can have multiple secondary windings for several isolated outputs. One or more of these secondary channels are normally utilized internally by the converter itself to provide the necessary bias voltages for the controller. The transformer uses an EFD20 type core with a primary inductance of 45 μ H. The converter runs in CCM at full load over the entire input voltage range, but it will operate in DCM under light loads. The LM5072's built-in slope compensation helps stabilize the feedback loop when the duty cycle exceeds 50% in 24V AUX power operation.

A additional transformer winding is used to provide the bias voltage (VCC) to the LM5072 IC. Although the LM5072 controller includes an internal startup regulator which can support the bias requirement indefinitely, the transformer winding produces an output about 2V higher than the startup regulator output, thus shutting off the startup regulator and reducing the power dissipation inside the IC. Given the low current limit value (15 mA nominal) of the high voltage startup regulator, the VCC line is not meant to source external loads greater than 3 mA in total. The external load of the VCC line is the “PoE Power” LED indicating the PoE operation mode.

Factors Limiting the Minimum Operating Input Voltage

The LM5072 supports operation with as low as 9V AUX power source. However, limited by the flyback power transformer design, the minimum AUX voltage of the evaluation board is 22V (voltage drops caused by RE1A and alike and DE1 reduce the VIN pin potential to about 20V).

The installed EFD20 type power transformer FA2267-AL is a low cost, area efficient solution to operate with a wide auxiliary input voltage range from 24V to 57V. However, it does not support 24W power operation with the lower input voltage. Under these conditions the excessive magnetic flux may saturate the transformer core. It is possible to operate with a lower voltage AUX source, if the output power level is reduced. If full power is required under low AUX input voltage, the power transformer will need to be redesigned. Contact National Semiconductor for assistance.

PoE Performance Characteristics

PoE INPUT POWER UP SEQUENCE

The PoE power up sequence is as follows. Note that the RTN pin (IC pin 8) is isolated from the +3.3V RTN output pin of the evaluation board:

1. The circuit first enters detection mode.
2. Depending on the PSE in use, the circuit may or may not go through classification mode.
3. The PSE enters full power application mode. Before the PoE input voltage reaches the UVLO threshold, the hot swap MOSFET is in the OFF state. Thus, all nodes in the non-isolated section of the power supply remain at high potential. The voltage across the hot swap MOSFET, namely the voltage across the RTN and VEE pins, will be approximately equal to the PoE input voltage seen across the VIN and VEE pins.
4. When the UVLO is released during the PoE input power up, the drain of the internal hot swap MOSFET is pulled down to VEE (IC pin 7) gradually as the input current charges up the input capacitors.
5. The VCC regulator powers up during the inrush sequence. During VCC regulator startup, it draws current on the order of 20mA, but this will likely not be noticed by the user. Once the RTN pin of the IC drops below 1.5V (referenced to VEE), and the gate of the hot swap MOSFET rises, power good is asserted by pulling the nPGOOD pin low.
6. Once power good has been asserted, the SS (Soft-Start) pin is released. The SS pin will rise at a rate equal to the SS current source, typically 10 μ A, divided by the SS pin capacitance, CE26.
7. After the soft start is complete, the switching regulator achieves output regulation, and the converter enters steady state operation. The auxiliary winding will raise the VCC voltage to about 10.5V, thus shutting down the internal regulator and increasing efficiency.

Figure 5 shows key waveforms during a normal PoE power up sequence. Please note that the PSE used in the test goes through detection mode, but opts out of classification mode and directly enters full power application mode.

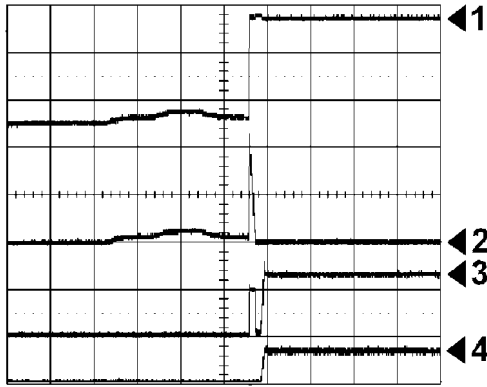

20205203

Horizontal Resolution: 50 ms/div.

Trace 1: PoE input voltage across the VIN and VEE pins. 20V/div.

Trace 2: Voltage across the RTN and VEE pins, namely the voltage across the Hot Swap MOSFET. 20V/div.

Trace 3: The input current. 0.2A/div.

Trace 4: The 3.3V output voltage. 2V/div.

FIGURE 5. PoE Power Up Sequence with a Midspan PSE**AUXILIARY INPUT POWER UP SEQUENCE**

The AUX input power up sequence is simpler:

1. AUX power application quickly charges the input capacitors. The AUX input inrush limit resistors limit the inrush current and prevent any overshoot of the voltage across the VIN and RTN pins.
2. When the VCC regulator starts up, the PWM controller begins soft start.
3. After soft start, the switching regulator achieves output regulation, and the converter enters steady state operation. The auxiliary winding will raise the VCC voltage to about 10.5V, thus shutting down the internal regulator and increasing efficiency.

Figure 6 shows key waveforms during a normal AUX power up sequence.

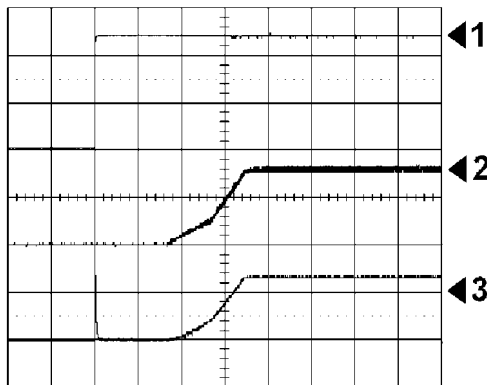

20205204

Horizontal Resolution: 5 ms/div.

Trace 1: AUX input voltage (VIN to RTN pins). 10V/div.

Trace 2: The 3.3V output voltage. 2V/div.

Trace 3: The input current. 1A/div.

FIGURE 6. AUX Power Up Sequence**OUTPUT DEAD SHORT RESPONSE AND OVER CURRENT PROTECTION**

The evaluation board survives the output dead short condition by running into re-try mode (hiccup) or cycle-by-cycle peak current limit mode, depending on the input voltage condition when the fault occurs. Applying a dead short to the +3.3V line causes a number of protection mechanisms to take place sequentially. They are:

1. The feedback signal increases the duty cycle in an attempt to maintain the output voltage. This initiates cycle-by-cycle over-current limiting which turns off the main switch when the current sense (CS) pin exceeds the current limit threshold.
2. The current in the internal hot swap MOSFET increases until it is current limited around 800 mA. Some overshoot in the current will be observed, as it takes time for the current limit amplifier to react and change the operating mode of the MOSFET.
3. Because linear current limiting is accomplished by driving the MOSFET into the saturation region, the drain voltage (RTN pin) rises. When it reaches 2.5V with respect to VEE, power good is de-asserted and the nPGOOD pin voltage rises.
4. The de-assertion of power good causes the discharge of the soft-start capacitor, which disables all switching action in the dc-dc converter.
5. Once the switching stops, the current in the internal MOSFET will decrease and the drain voltage will fall back below 1.5V with respect to VEE. When power good is re-asserted, the dc-dc converter will automatically restart with a new soft-start sequence.

Figure 7 and Figure 8 show cycle-by-cycle peak current limit in response to an output dead short with a 24V AUX input and 48V PoE input, respectively. The short-circuit condition results in a peak current of about 3.2A in the primary circuit. This peak current produces about 0.5V peak at the CS pin, initiating cycle-by-cycle peak current limit mode. The duty cycle is thus greatly reduced, which in turn limits the AUX input dc current to about 0.39A, and the PoE input dc current to about 0.16A, respectively.

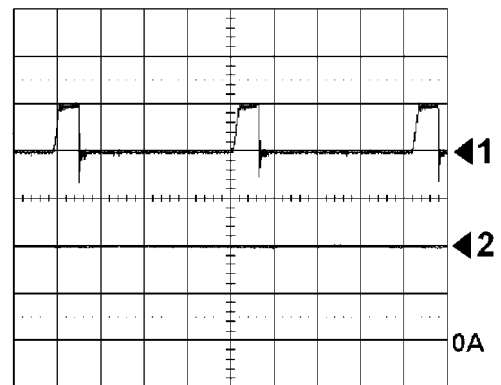

20205205

Horizontal Resolution: 1 μ s/div.

Trace 1: Current sense voltage across RE15. 0.5V/div.

Trace 2: The input current from the AUX power source. 200 mA/div

FIGURE 7. Cycle-by-cycle Peak Current Limit under AUX Input and Output Dead Short Condition

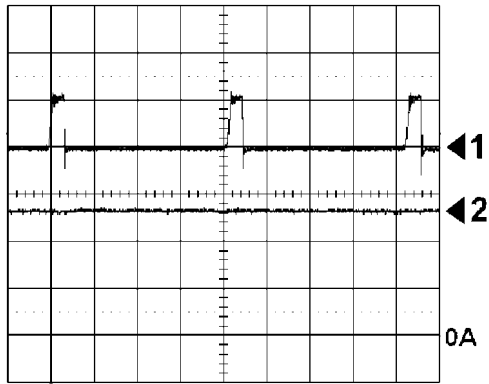

20205206

Horizontal Resolution: 1 μ s/div.

Trace 1: Current sense voltage across RE15. 0.5V/div.

Trace 2: The input current from the AUX power source. 100 mA/div

FIGURE 8. Cycle-by-cycle Peak Current Limit under 48V PoE Input and Output Dead Short Condition

Figure 9 shows key waveforms of over-current protection by the hot swap MOSFET's dc current limit. The PoE input voltage is at 38V. The input current exceeds the 800 mA current limit of the hot swap MOSFET, and causes the voltage at the RTN pin to rise rapidly. It also discharges the soft start capacitor CE26 connected to the SS pin, and the circuit enters the automatic retry mode as long as the over-current condition is present.

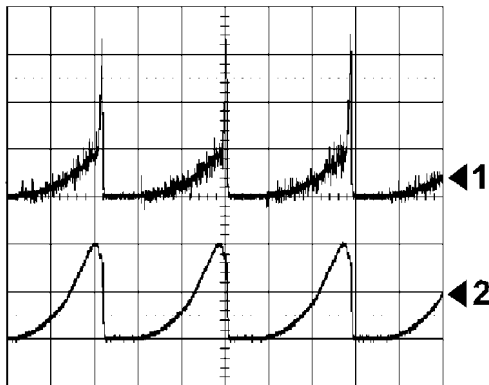

20205207

Horizontal Resolution: 5 ms/div.

Trace 1: The voltage of the RTN pin (referenced to the VEE pin). 0.5V/div.

Trace 2: The PoE input current. 0.5A/div

FIGURE 9. Retry Mode under 38V PoE Input and Output Over Current Condition

STEP RESPONSE

Figure 10 shows the step load response at V_{in} equal to 48V. The load current changes in step between 1A and 7A.

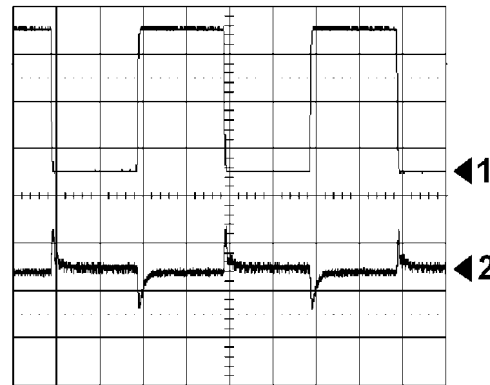

20205208

Horizontal Resolution: 0.5 ms/div.

Trace 1: Load current step changes between 1A and 7A. 2A/div.

Trace 2: The 3.3V output voltage response (AC coupled). 0.5V/div.

FIGURE 10. Output Voltage Step Load Response

RIPPLE CURRENT AND VOLTAGE

Figure 11 and Figure 12 show the PoE and AUX input ripple current, respectively, under full load. In both cases, the input ripple current is attenuated to less than 10 mA pk-pk by the input filter.

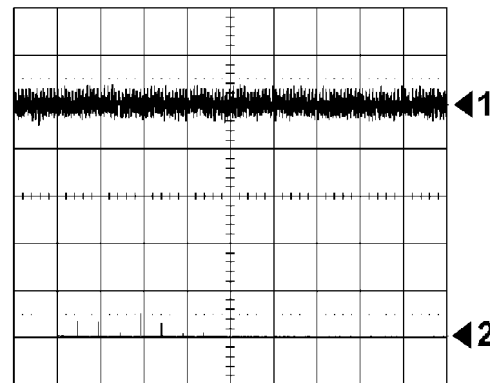

20205209

Horizontal Resolution: 50 μ s/div.

Trace 1: The PoE input current ripples (AC coupled). 20 mA/div.

Trace 2: The FFT of Trace 1. Horizontal 500 kHz/div. Vertical 5 mA/div

FIGURE 11. PoE Input Current Ripples under Full Load

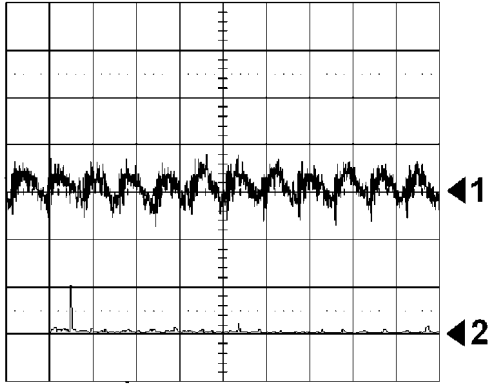

20205210

Horizontal Resolution: 5 μ s/div.

Trace 1: The AUX input current ripples (AC coupled). 10 mA/div.

Trace 2: The FFT of Trace 1 showing the peak value of the harmonics. Horizontal 500 kHz/div. Vertical 2.5 mA/div.

FIGURE 12. AUX Input Current Ripple Under Full Load

Figure 13 shows the output ripple voltage. The FFT of the output ripple voltage indicates that the ripple harmonics are below 15 mV pk-pk.

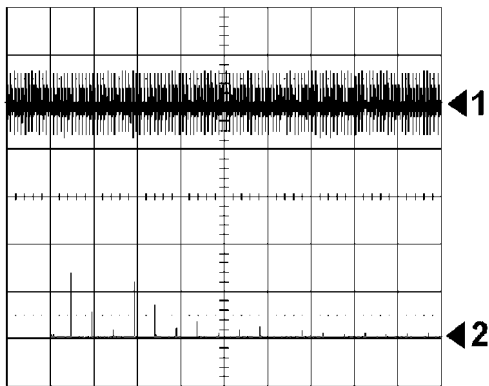

20205211

Horizontal Resolution: 50 μ s/div.

Trace 1: The 3.3V output voltage ripples (AC coupled). 0.2V/div

Trace 2: The FFT of Trace 1 showing the peak value of the harmonics. Horizontal 500 kHz/div. Vertical 5 mV/div

FIGURE 13. Output Ripple Voltage under Full Load

A Note on the Use of Common-Mode Choke

A location is reserved on the evaluation board for an optional input common mode filter. For some special applications that have very strict EMI requirements, the common mode filter consisting of the choke U6 and two Y capacitors CE12 and CE13 can be used. On the original evaluation board, these three components are not populated, and U6's pads are shorted with bus wires. When a common mode filter is required, a Coilcraft D1882-AL or equivalent can be used for U6, along with a Syfer 1808JA250102MCTPY2 or equivalent for CE12 and CE13.

Bill of Materials

Part 1. PoE Circuit BOM

ITEM	PART NUMBER	DESCRIPTION	VALUE
BR1	CBR1-D020S	DIODE BRIDGE, SMDIP, CENTRAL	1A, 200V
BR2	CBR1-D020S	DIODE BRIDGE, SMDIP, CENTRAL	1A, 200V
CE1	C2012X7R1E474K	CAPACITOR, CER, CC0805, TDK	0.47 μ F, 25V
CE2	NU		
CE3	NU		
CE4	C5750X7R2A475M	CAPACITOR, CER, CC2220, TDK	4.7 μ F, 100V
CE6	C5750X7R2A475M	CAPACITOR, CER, CC2220, TDK	4.7 μ F, 100V
CE6	EEV-HA2A220P	CAPACITOR, AL ELEC, PANASONIC	22 μ F, 100V
CE7	C3216X5R0J226M	CAPACITOR, CER, CC1206, TDK	22 μ F, 6.3V
CE8	C3216X5R0J226M	CAPACITOR, CER, CC1206, TDK	22 μ F, 6.3V
CE9	C3216X5R0J226M	CAPACITOR, CER, CC1206, TDK	22 μ F, 6.3V
CE10	C3216X5R0J226M	CAPACITOR, CER, CC1206, TDK	22 μ F, 6.3V
CE11	C2012X7R1E474K	CAPACITOR, CER, CC0805, TDK	0.47 μ F, 25V
CE12	NU		
CE13	NU		
CE14	NU		
CE15	C3216X5R0J226M	CAPACITOR, CER, CC1206, TDK	22 μ F, 6.3V
CE16	EMVY6R3ADA331MF80G	CAPACITOR, AL ELEC, CHEMI-ON	330 μ F, 6.3V
CE19	C2012X5R1C105K	CAPACITOR, CER, CC0805, TDK	1.0 μ F, 16V
CE20	C2012X7R1E474K	CAPACITOR, CER, CC0805, TDK	0.4 μ F, 25V
CE21	C0805C473K5RAC	CAPACITOR, CER, CC0805, KEMET	0.047 μ F, 50V
CE22	NU		
CE23	C0805C102K5RAC	CAPACITOR, CER, CC0805, KEMET	1000 pF, 50V
CE25	C0805C104K5RAC	CAPACITOR, CER, CC0805, KEMET	0.1 μ F, 50V
CE26	C0805C473K5RAC	CAPACITOR, CER, CC0805, KEMET	0.047 μ F, 50V
CE27	NU		
CE28	C4532X7R3D222K	CAPACITOR, CER, CC1812, TDK	2200 pF, 2 kV
CE29	C3216X7R2A104K	CAPACITOR, CER, CC1206, TDK	0.1 μ F, 100V
CE31	C0805C473K5RAC	CAPACITOR, CER, CC0805, KEMET	0.047 μ F, 50V
CE30	NU		
DE1	S3BB-13	DIODE, SMB, DIODE INC	3A, 100V
DE2	NU		
DE3	BAT54S	DUAL SCHOTTKY, SOT-23, DIODE INC	
DE4	CMHD4448	DIODE, SOD123, CENTRAL	125 mA, 75V
DE5	NU		
DE6	CMR1U-01M	DIODE, SMA, CENTRAL	1A, 100V
DE7	NU		
P1	PJ-102A	POWER JACK	
JE4	NU		
JE5	3104-2-00-01-00-00-080	POST, MILL MAX	
JE6	3104-2-00-01-00-00-080	POST, MILL MAX	
JE7	NU		
LE1	DO3308P-682MLD	SM INDUCTOR, COILCRAFT	6.8 μ H
LE3	DO3316T-331MLD	SM INDUCTOR, COILCRAFT	0.33 μ H
LED1	SSL-LXA228GC-TR11	LED, GREEN, LUMEX	
TP1	NU		
TP2	NU		

ITEM	PART NUMBER	DESCRIPTION	VALUE
TP3	5012K-ND	TEST POINT, KEYSTONE	
TP4	5012K-ND	TEST POINT, KEYSTONE	
TP7	5012K-ND	TEST POINT, KEYSTONE	
TP8	5012K-ND	TEST POINT, KEYSTONE	
TP12	NU		
Q1A	SI7898DP	MOSFET, N-CH, PowerPAK, VISHAY	150V, 4.8A
Q1B	NU		
Q2	BSC022N03SG	MOSFET, N-CH, PowerPAK, INFINEON	30V, 50A
QE5	SI2301	MOSFET, P-CH, SOT-23, VISHAY	
QE6	SI2301	MOSFET, P-CH, SOT-23, VISHAY	
RE1A	CRCW12068R20J	RESISTOR	8.20 Ohm
RE1B	CRCW12068R20J	RESISTOR	8.20 Ohm
RE1C	CRCW12068R20J	RESISTOR	8.20 Ohm
RE1D	CRCW12068R20J	RESISTOR	8.20 Ohm
RE2A	CRCW12068R20J	RESISTOR	8.20 Ohm
RE2B	CRCW12068R20J	RESISTOR	8.20 Ohm
RE2C	CRCW12068R20J	RESISTOR	8.20 Ohm
RE2D	CRCW12068R20J	RESISTOR	8.20 Ohm
RE3	CRCW080520R0F	RESISTOR	20 Ohm
RE4	NU		
RE5	CRCW08053321F	RESISTOR	3.32 k Ω
RE6	CRCW080524R9J	RESISTOR	24.9 Ohm
RE7	CRCW080510R0F	RESISTOR	10 Ohm
RE8	NU		
RE9	CRCW08051000F	RESISTOR	100 Ohm
RE10	NU		
RE11	NU		
RE12	CRCW08052432F	RESISTOR	24.3 k Ω
RE13	CRCW08054991F	RESISTOR	4.99 k Ω
RE14	CRCW12060R47F	RESISTOR	0.47 Ohm
RE15	CRCW12060R47F	RESISTOR	0.47 Ohm
RE16	NU		
RE17	CRCW08055900F	RESISTOR	1 k Ω
RE18	CRCW08051472F	RESISTOR	14.7 k Ω
RE19	NU		
RE20	CRCW08051001F	RESISTOR	1 k Ω
RE21	CRCW08052102F	RESISTOR	21.0 k Ω
RE22	NU		
RE23	CRCW08051582F	RESISTOR	15.8 k Ω
RE25	CRCW12060R47F	RESISTOR	0.47 Ohm
RE26	NU		
RE28	CRCW08050R0J	RESISTOR	332 Ohm
RE29	CRCW12062492F	RESISTOR	24.9 k Ω
RE34	CRCW08050R0J	RESISTOR	0 Ohm
U5	LM5072-80	POE PI AND PWM CTRL, NATIONAL	
U6	SHORT LEADS		
U7	FA2677-AL	XFMR, FLYBACK, EFD20, COILCRAFT	
U11	FA2659-AL	PULSE XFMR, 1:1, COILCRAFT	
UE2	PS2811-1-M	OPTO-COUPLER, NEC	

ITEM	PART NUMBER	DESCRIPTION	VALUE
UE3	LMV431A	REFERENCE, SOT23-3, NATIONAL	
ZE1	CMZ5944B	ZENER, 62V, SMA, CENTRAL	
ZE2	SMAJ58A	TVS, 58V, SMA, DIODE INC	
ZE3	CMPZ4619	ZENER, 3.0V, SOT23-3 CENTRAL	

Part 2. PHYTER BOM

ITEM	PART NUMBER	DESCRIPTION	VALUE
C1		CAPACITOR, TAN, CC7343	33 μ F, 35V
C2		CAPACITOR, TAN, CC7343	33 μ F, 35V
C3		CAPACITOR, CER, C0805, KEMET	33 pF, 50V
C4		CAPACITOR, CER, C0805, KEMET	33 pF, 50V
C5		CAPACITOR, TAN, CC7343	10 μ F, 35V
C6		CAPACITOR, CER, CC0603, KEMET	0.1 μ F, 50V
C7		CAPACITOR, CER, CC0603, KEMET	0.1 μ F, 50V
C8		CAPACITOR, CER, CC0603, KEMET	0.1 μ F, 50V
C9		CAPACITOR, TAN, CC3528	68 μ F, 6V
C10		CAPACITOR, CER, CC0603, KEMET	0.1 μ F, 50V
C11		CAPACITOR, CER, CC0603, KEMET	0.1 μ F, 50V
C12		CAPACITOR, TAN, CC3528	33 μ F, 6V
C13		CAPACITOR, CER, CC0603, KEMET	0.1 μ F, 50V
C14		CAPACITOR, CER, CC0603, KEMET	0.1 μ F, 50V
C15		CAPACITOR, CER, CC0603, KEMET	0.1 μ F, 50V
C16		CAPACITOR, CER, CC0603, KEMET	0.1 μ F, 50V
C17		CAPACITOR, TAN, CC7343	10 μ F, 35V
C18		CAPACITOR, CER, CC0603, KEMET	0.1 μ F, 50V
C20		CAPACITOR, TAN, CC7343	10 μ F, 35V
C21		CAPACITOR, CER, CC0603, KEMET	0.1 μ F, 50V
C22		CAPACITOR, CER, CC0603, KEMET	0.1 μ F, 50V
C23		CAPACITOR, CER, CC0603, KEMET	0.1 μ F, 50V
C49		CAPACITOR, CER, CC0603, KEMET, -E Board ONLY	8 pF, 50V
C50		CAPACITOR, CER, CC0603, KEMET, -E Board ONLY	8 pF, 50V
C53		CAPACITOR, CER, CC0603, KEMET, -E Board ONLY	8 pF, 50V
C54		CAPACITOR, CER, CC0603, KEMET, -E Board ONLY	8 pF, 50V
DS1	LTM673-R1S2-35	LED GREEN, OSRAM	
DS2	LTM673-R1S2-35	LED GREEN, OSRAM	
DS3	LTM673-R1S2-35	LED GREEN, OSRAM	
DS4	LTM673-R1S2-35	LED GREEN, OSRAM	
J1	CN MII-MALE	CONNECTOR, MII	
J2		TEST POINT, KEYSTONE	
J3		TEST POINT, KEYSTONE	
J4		TEST POINT, KEYSTONE	
J5		TEST POINT, KEYSTONE	
J6		TEST POINT, KEYSTONE	
J7		TEST POINT, KEYSTONE	
J8		TEST POINT, KEYSTONE	
J9		TEST POINT, KEYSTONE	

ITEM	PART NUMBER	DESCRIPTION	VALUE
J10	NU		
J11	NU		
J13	CN-PHONE8P8C-RA-SHLD	CONNECTOR RJ45, -E BOARD ONLY	
J15		TEST POINT, KEYSTONE	
J16		TEST POINT, KEYSTONE	
J18	NU		
R1	CRCW060333R0J	RESISTOR	33 Ohm
R2	CRCW060333R0J	RESISTOR	33 Ohm
R3	CRCW060333R0J	RESISTOR	33 Ohm
R4	CRCW060333R0J	RESISTOR	33 Ohm
R5	CRCW060333R0J	RESISTOR	33 Ohm
R6	CRCW060333R0J	RESISTOR	33 Ohm
R7	CRCW06032201F	RESISTOR	2.2 k Ω
R8	CRCW06032201F	RESISTOR	2.2 k Ω
R9	CRCW06032201F	RESISTOR	2.2 k Ω
R10	CRCW06032201F	RESISTOR	2.2 k Ω
R11	CRCW06032201F	RESISTOR	2.2 k Ω
R12	CRCW06032201F	RESISTOR	2.2 k Ω
R13	CRCW06032201F	RESISTOR	2.2 k Ω
R14	CRCW06032201F	RESISTOR	2.2 k Ω
R15	CRCW08050R0J	RESISTOR	0 Ohm
R16	CRCW06031002F	RESISTOR	10 k Ω
R17	CRCW060333R0J	RESISTOR	33 Ohm
R18	CRCW060333R0J	RESISTOR	33 Ohm
R19	CRCW060333R0J	RESISTOR	33 Ohm
R20	CRCW060333R0J	RESISTOR	33 Ohm
R21	CRCW060333R0J	RESISTOR	33 Ohm
R22	CRCW060333R0J	RESISTOR	33 Ohm
R23	CRCW060333R0J	RESISTOR	33 Ohm
R24	CRCW060333R0J	RESISTOR	33 Ohm
R25	CRCW060333R0J	RESISTOR	33 Ohm
R26	CRCW06032200F	RESISTOR	220 Ohm
R28	CRCW08051501F	RESISTOR	1.5 k Ω
R29	CRCW06032201F	RESISTOR	2.2 k Ω
R30	CRCW060324871F	RESISTOR	4.87 k Ω
R31	CRCW06032201F	RESISTOR	2.2 k Ω
R32	CRCW06032201F	RESISTOR	2.2 k Ω
R33	CRCW060349R9J	RESISTOR	49.9 Ohm
R34	CRCW060349R9J	RESISTOR	49.9 Ohm
R35	CRCW060349R9J	RESISTOR	49.9 Ohm
R36	CRCW060349R9J	RESISTOR	49.9 Ohm
R37	CRCW06032200F	RESISTOR	220 Ohm
R39	CRCW06032200F	RESISTOR	220 Ohm
R41	CRCW06032200F	RESISTOR	220 Ohm
R42	CRCW12060R0J	RESISTOR	0 Ohm
R43	CRCW12060R0J	RESISTOR	0 Ohm
R44	CRCW12060R0J	RESISTOR	0 Ohm
R45	CRCW12060R0J	RESISTOR	0 Ohm
R50	CRCW12060R0J	RESISTOR	0 Ohm

ITEM	PART NUMBER	DESCRIPTION	VALUE
R51	CRCW12060R0J	RESISTOR	0 Ohm
R52	CRCW12060R0J	RESISTOR	0 Ohm
R53	CRCW12060R0J	RESISTOR	0 Ohm
R54	CRCW12060R0J	RESISTOR	0 Ohm
R55	CRCW12060R0J	RESISTOR	0 Ohm
R56	CRCW12060R0J	RESISTOR	0 Ohm
R57	CRCW12060R0J	RESISTOR	0 Ohm
U1	DP83848-IVV	PHY TRANSCEIVER, NATIONAL	
U4	ETH1-230LD	TRANSFORMER, ETHERNET, COILCRAFT, -E BOARD ONLY	
U8	NU		
U9	NU		
U10	NU		
UE13	0838-1X1T-W6	CONNECTOR, INTEGRATED WITH ETHERNET TRANSFORMER, BEL STEWARD, -I BOARD ONLY	
Y1	FOXSLF/250F-20	CRYSTAL, HC49-US,	25 MHz

Note: NU stands for Not Used, namely not populated.

Notes

For more National Semiconductor product information and proven design tools, visit the following Web sites at:

Products		Design Support	
Amplifiers	www.national.com/amplifiers	WEBENCH	www.national.com/webench
Audio	www.national.com/audio	Analog University	www.national.com/AU
Clock Conditioners	www.national.com/timing	App Notes	www.national.com/appnotes
Data Converters	www.national.com/adc	Distributors	www.national.com/contacts
Displays	www.national.com/displays	Green Compliance	www.national.com/quality/green
Ethernet	www.national.com/ethernet	Packaging	www.national.com/packaging
Interface	www.national.com/interface	Quality and Reliability	www.national.com/quality
LVDS	www.national.com/lvds	Reference Designs	www.national.com/refdesigns
Power Management	www.national.com/power	Feedback	www.national.com/feedback
Switching Regulators	www.national.com/switchers		
LDOs	www.national.com/ldo		
LED Lighting	www.national.com/led		
PowerWise	www.national.com/powerwise		
Serial Digital Interface (SDI)	www.national.com/sdi		
Temperature Sensors	www.national.com/tempsensors		
Wireless (PLL/VCO)	www.national.com/wireless		

THE CONTENTS OF THIS DOCUMENT ARE PROVIDED IN CONNECTION WITH NATIONAL SEMICONDUCTOR CORPORATION ("NATIONAL") PRODUCTS. NATIONAL MAKES NO REPRESENTATIONS OR WARRANTIES WITH RESPECT TO THE ACCURACY OR COMPLETENESS OF THE CONTENTS OF THIS PUBLICATION AND RESERVES THE RIGHT TO MAKE CHANGES TO SPECIFICATIONS AND PRODUCT DESCRIPTIONS AT ANY TIME WITHOUT NOTICE. NO LICENSE, WHETHER EXPRESS, IMPLIED, ARISING BY ESTOPPEL OR OTHERWISE, TO ANY INTELLECTUAL PROPERTY RIGHTS IS GRANTED BY THIS DOCUMENT.

TESTING AND OTHER QUALITY CONTROLS ARE USED TO THE EXTENT NATIONAL DEEMS NECESSARY TO SUPPORT NATIONAL'S PRODUCT WARRANTY. EXCEPT WHERE MANDATED BY GOVERNMENT REQUIREMENTS, TESTING OF ALL PARAMETERS OF EACH PRODUCT IS NOT NECESSARILY PERFORMED. NATIONAL ASSUMES NO LIABILITY FOR APPLICATIONS ASSISTANCE OR BUYER PRODUCT DESIGN. BUYERS ARE RESPONSIBLE FOR THEIR PRODUCTS AND APPLICATIONS USING NATIONAL COMPONENTS. PRIOR TO USING OR DISTRIBUTING ANY PRODUCTS THAT INCLUDE NATIONAL COMPONENTS, BUYERS SHOULD PROVIDE ADEQUATE DESIGN, TESTING AND OPERATING SAFEGUARDS.

EXCEPT AS PROVIDED IN NATIONAL'S TERMS AND CONDITIONS OF SALE FOR SUCH PRODUCTS, NATIONAL ASSUMES NO LIABILITY WHATSOEVER, AND NATIONAL DISCLAIMS ANY EXPRESS OR IMPLIED WARRANTY RELATING TO THE SALE AND/OR USE OF NATIONAL PRODUCTS INCLUDING LIABILITY OR WARRANTIES RELATING TO FITNESS FOR A PARTICULAR PURPOSE, MERCHANTABILITY, OR INFRINGEMENT OF ANY PATENT, COPYRIGHT OR OTHER INTELLECTUAL PROPERTY RIGHT.

LIFE SUPPORT POLICY

NATIONAL'S PRODUCTS ARE NOT AUTHORIZED FOR USE AS CRITICAL COMPONENTS IN LIFE SUPPORT DEVICES OR SYSTEMS WITHOUT THE EXPRESS PRIOR WRITTEN APPROVAL OF THE CHIEF EXECUTIVE OFFICER AND GENERAL COUNSEL OF NATIONAL SEMICONDUCTOR CORPORATION. As used herein:

Life support devices or systems are devices which (a) are intended for surgical implant into the body, or (b) support or sustain life and whose failure to perform when properly used in accordance with instructions for use provided in the labeling can be reasonably expected to result in a significant injury to the user. A critical component is any component in a life support device or system whose failure to perform can be reasonably expected to cause the failure of the life support device or system or to affect its safety or effectiveness.

National Semiconductor and the National Semiconductor logo are registered trademarks of National Semiconductor Corporation. All other brand or product names may be trademarks or registered trademarks of their respective holders.

Copyright© 2008 National Semiconductor Corporation

For the most current product information visit us at www.national.com



**National Semiconductor
Americas Technical
Support Center**
Email:
new.feedback@nsc.com
Tel: 1-800-272-9959

**National Semiconductor Europe
Technical Support Center**
Email: europe.support@nsc.com
German Tel: +49 (0) 180 5010 771
English Tel: +44 (0) 870 850 4288

**National Semiconductor Asia
Pacific Technical Support Center**
Email: ap.support@nsc.com

**National Semiconductor Japan
Technical Support Center**
Email: jpn.feedback@nsc.com