

Liquid-Level Monitoring Using a Pressure Sensor

— By Amy Le, Applications Engineer

Liquid-level monitoring plays an important role in today's automotive, oil, water, pressure, and gas industries, to name a few. For example, pumping oil into a storage tank requires liquid-level monitoring to prevent spillage. Draining liquid out of a silo into bottles also requires liquid-level monitoring for volume control.

This article will explain how to automate a liquid monitoring system using a pressure sensor. Since obtaining the pressure is just one vital piece of the information, how to convert the sensor's output voltage into the liquid's height using an analog-to-digital converter (ADC) will also be explained. Details of the pressure sensor, ADC connections, system calibration and calculations, as well as an example application, are available to guide designers through the development phase.

Level-Sensing Theory

The height of liquid in a container can be measured using a pressure sensor. Placed at the top of the container, the pressure sensor is connected to an open-ended tube that is submerged in the container. The amount of water in the container exerts a proportional amount of pressure on the sensor via the trapped air in the tube. At its output, the sensor produces a pressure-equivalent voltage.

Essentially, the pressure sensor is a Wheatstone Bridge (*Figure 1*). Changes to the pressure on the bridge are analogous to the changes in the value of the bridge's resistors, R .

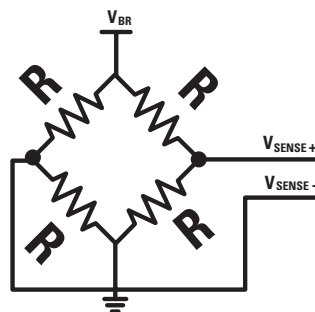

Figure 1. Bridge Sensor

Pressure Sensor

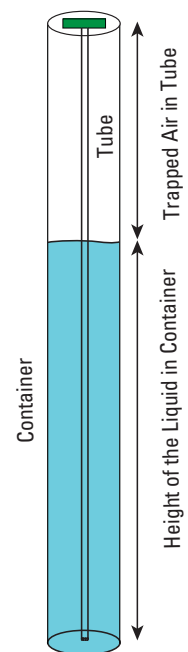

Figure 2. Container



Liquid-Level Monitoring Using a Pressure Sensor

Hardware

Pressure Sensor

The differential sensor used in the example application is GE NovaSensor's NPC-1210 series. The NPC-1210 has a typical Full Scale Output (FSO) of 50 mV for 10 inches of water. That is, 10 inches of water in the container corresponds to a typical sensor's differential output voltage of 50 mV. This linear relationship is useful information for calculating the liquid's height and determining the appropriate ADC and amplifier for the system.

This particular sensor was selected due to its low sensitivity characteristic, which means its output will be in the millivolts range. Since the example application has a small amount of liquid volume (approximately 540 inches³), a sensitive pressure sensor is adequate. It is important to select the pressure sensor appropriate for a given application. National Semiconductor's Sensor WEBENCH® online design tool (national.com/appinfo/webench/sensorpath.html) can help customers in choosing the appropriate sensor based on input range and desired accuracy.

Sensor Reference Board

National's newest sensor reference boards (*Order No: SP1202S01RB and SP1602S02RB*) are ideal sensor interface developments for liquid-level monitoring systems. The SP1202S01RB sensor reference board has a differential to single-ended configuration using an instrumentation amplifier connected to a single-ended, 12-bit, single-channel ADC121S101 converter. The latter board also has an instrumentation amplifier but uses a differential, 16-bit, single-channel ADC161S626 device in a single-ended fashion.

Both boards serve the similar function of amplifying the sensor's output voltage and converting it to an output code. However, because the resolution for the SP1602S02RB sensor reference board is higher due to the 16-bit ADC, it is more sensitive to changes in the liquid's level than the SP1202S01RB sensor reference board.

Both configurations contain the gain stage to amplify the millivolts sensor output to the reasonable 0V to 4.1V ADC operating range. The output code of the ADC is read by a microcontroller via SPI and is uploaded to a PC to be analyzed. An example block diagram of the differential to single-ended signal path can be seen in *Figure 3*.

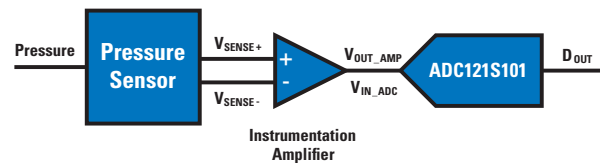

Figure 3. SP1202S01RB Sensor Reference Board Block Diagram

Pressure Sensor Calibration

Finding the linear relationship between the sensor's output voltage and height of the liquid requires calibrating the particular system. The NPC-1210 sensor datasheet states that a typical relationship is 50 mV to 10 inches of liquid. By pouring in the container 'x' inches of liquid and then measuring the sensor's differential output voltage 'Δy', where Δy is [(V_{SENSE+}) - (V_{SENSE-})], the sensor can be calibrated.

$$\Delta V_{\text{SENSOR_OUT}} = (V_{\text{SENSE+}}) - (V_{\text{SENSE-}}) \quad (1)$$

$$\Delta V_{\text{SENSOR_OUT}} = \left(\frac{\Delta y}{x} \right) \times (\text{Height}) \quad (2)$$

This linear relationship can be used to find the sensor's differential output voltage, ΔV_{SENSOR_OUT}, at a new height as seen in Equation 2.

The Liquid's Height Calculation

As shown in *Figure 3*, the liquid-level monitoring signal path has three stages. For that reason, calculating the liquid's height in terms of the ADC and amplifier requires several processes. The first step is finding the gain of the amplifier and multiplying this gain with the sensor's output voltage, ΔV_{SENSOR_OUT}, to obtain the ADC input voltage, V_{IN_ADC}.

$$V_{\text{IN_ADC}} = V_{\text{OUT_AMP}} = (\Delta V_{\text{SENSOR_OUT}}) \times (\text{Gain}) \quad (3)$$

Finding the gain of any amplifier stage can be cumbersome. For simplification, an example calculation for the instrumentation amplifier (*Figure 4*) used in the example application can be seen in a series of equations (4a – 4e). These calculations use superposition and simple op amp equations to derive the ADC input, V_{IN_ADC} , and gain of the instrumentation amplifier stage. To obtain a good common-mode rejection, RF_1 should be equal to RF_2 ; RA_1 should be equal to RA_2 ; and RB_1 should be equal to RB_2 .

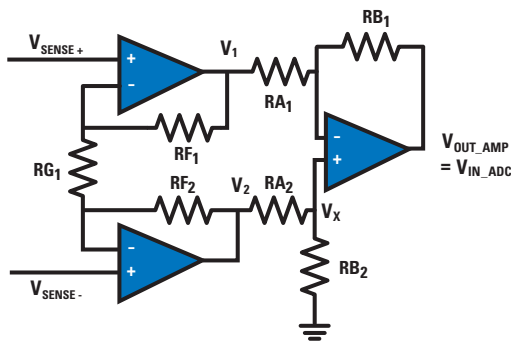

Figure 4. Instrumentation Amplifier

$$V_1 = (V_{SENSE+}) \times \left(1 + \frac{RF_1}{RG_1}\right) + (V_{SENSE-}) \times \left(\frac{-RF_1}{RG_1}\right) \quad (4a)$$

$$V_2 = (V_{SENSE+}) \times \left(\frac{-RF_2}{RG_2}\right) + (V_{SENSE-}) \times \left(1 + \frac{RF_2}{RG_2}\right) \quad (4b)$$

$$V_x = \left(\frac{RB_2}{RB_2 + RA_2}\right) \times (V_2) \quad (4c)$$

$$V_{IN_ADC} = V_{OUT_AMP} = V_x \times \left[\frac{RB_1 + RA_1}{RA_1}\right] - V_1 \times \left(\frac{RB_1}{RA_1}\right) \quad (4d)$$

$$\text{Gain} = \frac{V_{IN_ADC}}{\Delta V_{SENSOR_OUT}} \quad (4e)$$

Next, simple differential (DIFF) and single-ended (SE) ADC formulas can be used to find the ADC output code, D_{OUT} . The appropriate equation is chosen based on the type of ADC used in a given system. In both configurations, V_{REF} is the ADC reference voltage and n is the ADC-bit resolution.

$$D_{OUT_DIFF} = \left(\frac{V_{IN_ADC}}{2 \times V_{REF}}\right) \times (2^n) \quad (5a)$$

$$D_{OUT_SE} = \left(\frac{V_{IN_ADC}}{V_{REF}}\right) \times (2^n) \quad (5b)$$

Finally, the output code is converted to the liquid's height using Equation 6a for a differential ADC or 6b for a single-ended ADC. These equations are derived from Equation 2 but differ from Equation 2 because ΔV_{SENSOR_OUT} is now written in terms of the ADC and amplifier gain.

$$\text{Height}_{DIFF} = \left[\frac{x}{\Delta y}\right] \times \left(\frac{1}{\text{Gain}}\right) \times \left[\frac{(D_{OUT_DIFF}) \times (2 \times V_{REF})}{(2^n)}\right] \quad (6a)$$

$$\text{Height}_{SE} = \left[\frac{x}{\Delta y}\right] \times \left(\frac{1}{\text{Gain}}\right) \times \left[\frac{(D_{OUT_SE}) \times (V_{REF})}{(2^n)}\right] \quad (6b)$$

Example Application

An example application is illustrated in *Figure 7* in which a container full of water is measured using the NPC-1210 pressure sensor. Water is continuously drained out of the container into an external water tub that contains an electrical pump. When the water level is low, the electrical pump turns on and pumps water back into the tube. When the water level reaches a predetermined point near the top, the pump turns off and awaits the lower trip point to turn on again as water is drained out of the tube. This cycle repeats until the power is turned off.

To create this continuous fluctuation of water level, a comparator with hysteresis (*Figure 5*), an inverter, and a relay switch are added to the previously mentioned hardware connections. The ADC's input is compared to the reference voltage of the comparator, V_{REF_COMP} (not to be confused with the reference voltage of the ADC). If V_{IN_ADC} is greater than

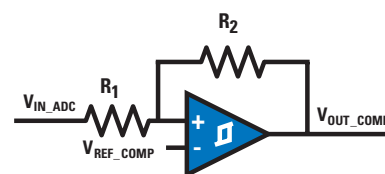

Figure 5. Comparator with Hysteresis

Liquid-Level Monitoring Using a Pressure Sensor

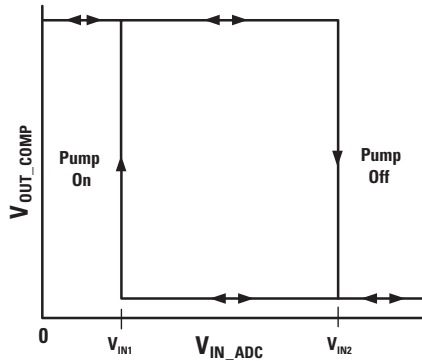

Figure 6. Hysteresis

V_{REF_COMP} , then the comparator's output is high; otherwise, it's low. As shown in *Figure 6*, hysteresis is added to the comparator to create two switching thresholds at V_{IN1} and V_{IN2} . These switching thresholds represent the positions when the pump turns on and off.

Equations 7a and 7b show how these thresholds can be easily adjusted by changing the comparator's resistors R_1 and R_2 . It is up to the designer to pick a comfortable reference voltage, V_{REF_COMP} , and available resistor values to get the desired threshold voltages.

$$V_{IN1} = \frac{[(V_{REF_COMP})(R_1 + R_2)] - [V_{CC} R_1]}{R_2} \quad (7a)$$

$$V_{IN2} = \frac{[(V_{REF_COMP}) \times (R_1 + R_2)]}{R_2} \quad (7b)$$

The comparator's output is connected to two powered FETs acting as a buffer. Although the inverter is not necessary, the FETs' main purpose is providing sufficient current to turn on the relay. Having one pin connected to AC power and the other unconnected, the relay switches between a pump-to-power connection and a pump-to-ground connection.

The application is a good demonstration for liquid-level monitoring systems that require a safety mechanism. Without depending on software, this hardware connection can turn off the pump when the water approaches the overflow point. The example application also illustrates the usefulness of the sensor reference board. Its complete signal path design makes enhancing any sensor applications significantly more convenient.

Conclusion

Liquid-level monitoring systems require the use of pressure sensors to measure the pressure, and thus the height, of the liquid. Since the sensor's output voltage is meaningless to the average users, an ADC is needed to convert the analog voltage to a digital language in which a computer's software can mathematically compute the height of the liquid. This signal path design is encapsulated in National's sensor reference boards. As illustrated in the example application, the SP1202S01RB sensor reference board is ideal for many pressure-sensor applications.

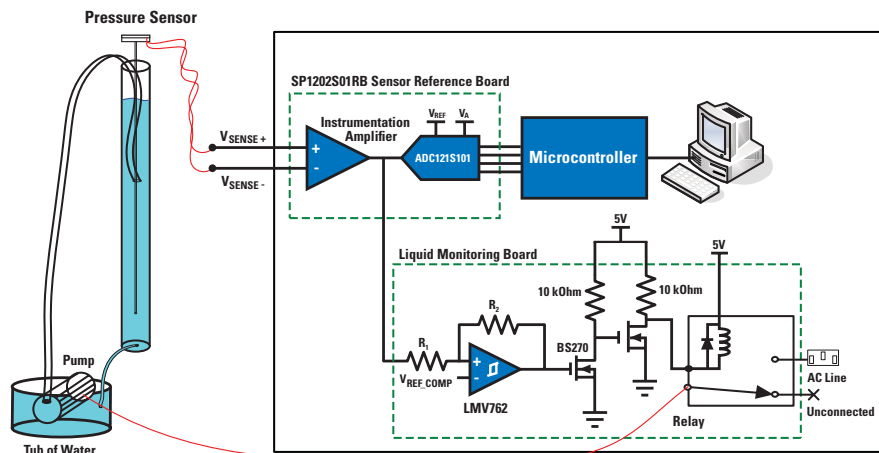

Figure 7. Liquid Monitoring System



DESIGN MADE EASY



**EXPLORE
& LEARN**

**COMPARE
& SELECT**

**DESIGN
& BUILD**

**Discover a wealth of
design resources**

Explore "how to" videos, online courses, articles, and the latest design technologies.

**Find the perfect mix of
products for your design**

Use National's online product catalog, downloadable collateral, and featured online sites to compare and select products.

**Design, build and
validate a solution**

Speed time-to-market with the new WEBENCH® Sensor Designer and enhanced WEBENCH Power Designer.

© 2008, National Semiconductor Corporation. National Semiconductor, and PowerWise are registered trademarks. All rights reserved.

national.com/easy



Design Tools

WEBENCH® Signal Path Designer® Tools

Design, simulate, and optimize amplifier circuits in this FREE online design and prototyping environment allowing you to:

- Synthesize an anti-alias filter
- Select the best amplifier/ADC combo for your system specs
- Make trade-offs based on SNR, SFDR, supply voltage
- Simulate real-world operating conditions using SPICE
- Receive samples in 24 hours

webench.national.com

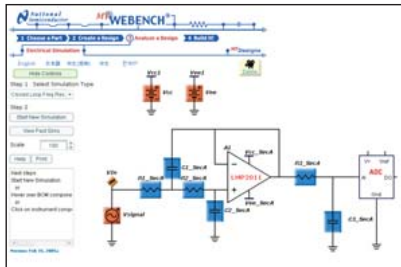

WaveVision 4.1 Evaluation Board

Test and evaluate A/D converters with National's easy-to use WaveVision 4.1 evaluation board. Each evaluation board comes complete with USB cable and support software.

Features and benefits:

- Plug-n-play ADC evaluation board
- USB 2.0 interface to PC
- PC-based data capture
- Easy data capture and evaluation
- Highlighted harmonic and SFDR frequencies
- Easy waveform examination
- Produces and displays FFT plots
- Dynamic performance parameter readout with FFT
- Produces and displays histograms



National Semiconductor
2900 Semiconductor Drive
Santa Clara, CA 95051
1 800 272 9959

Mailing address:
PO Box 58090
Santa Clara, CA 95052

Visit our website at:
www.national.com

**For more information,
send email to:**
new.feedback@nsc.com



Don't miss a single issue!

Subscribe now to receive email alerts when new issues of Signal Path Designer® are available:

signalpath.national.com/designer

Also, be sure to check out our Power Designer! View online today at:
power.national.com/designer

