



STEVAL-SPMD150V2

1.5 A bipolar stepper motor drive module (SPMD150STP) demonstration board

Data brief

Features

- Ready-to-use board for SPMD150STP demonstration
- Easy interfacing with PractiSPIN™ software
- Simulates:
 - Normal/half-step sequence and microstepping
 - Fast/slow decay
 - Forward/reverse
 - Enable
- Phase current selectable for acceleration/deceleration ramp, running and stop mode
- Possibility to program moving and waiting time sequences
- RoHS compliant

Description

This STEVAL-SPMD150V2 demonstration board is designed for evaluating the performance and the features of the SPMD150STP module. The board works in conjunction with the PractiSPIN™ HW and the PractiSPIN™.spmd SW, which allow the user to operate with the SPMD150STP module.

The SPMD150STP is part of the EASY POWER™ series of fully integrated modules designed to drive bipolar permanent-magnet stepper motors.

All EASY POWER modules offer an easy-to-use, fully-protected solution to implement precise position control, with high torque at rest, and without the need for external components. The module operates over a wide 12 V to 40 V input voltage range and supports an output maximum current of 1.5 A.

The SPMD150STP implements full/half-step and microstepping driving capability, working at a variable chopper frequency. It is possible to select



between fast and slow decay current. The module internally generates the phase sequence, significantly reducing the burden on the controller. Integration of a power MOSFET stage significantly reduces both commutation and conduction losses. The SPMD150STP offers complete output protection against all types of short conditions. The metal package acts as an integrated heatsink, with no ventilation or additional components required. The metal case also isolates the inner circuit from external agents, making the module suitable for operation in harsh environments.

The STEVAL-SPMD150V1 supports the following measurements and demonstrations: full/half-step, microstepping, CW/CCW, control behavior, motor current waveforms and measurements, movement sequences.

1 Circuit schematic

Figure 1. Circuit schematic

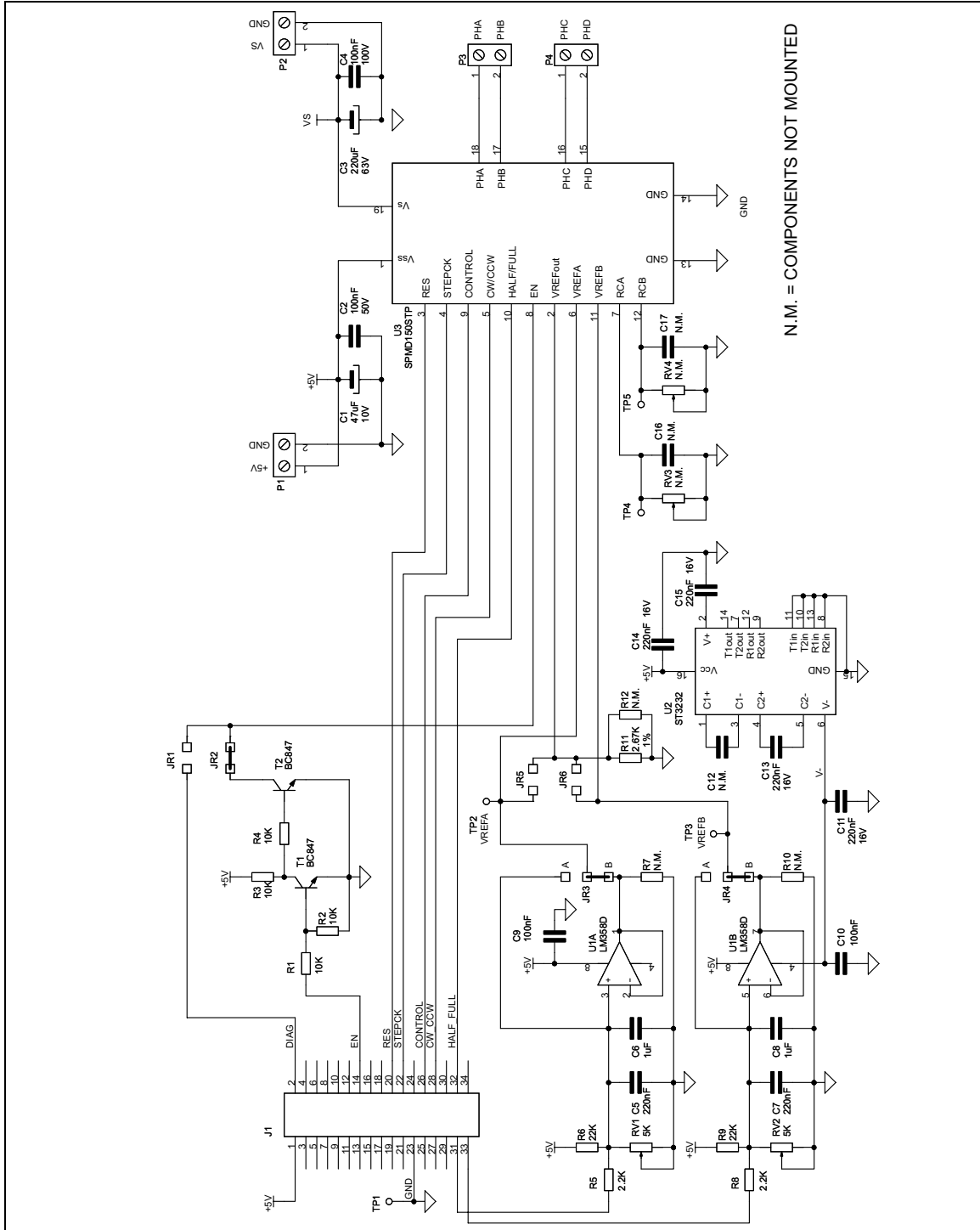

2 Revision history

Table 1. Document revision history

Date	Revision	Changes
24-Nov-2010	1	Initial release.

Please Read Carefully:

Information in this document is provided solely in connection with ST products. STMicroelectronics NV and its subsidiaries ("ST") reserve the right to make changes, corrections, modifications or improvements, to this document, and the products and services described herein at any time, without notice.

All ST products are sold pursuant to ST's terms and conditions of sale.

Purchasers are solely responsible for the choice, selection and use of the ST products and services described herein, and ST assumes no liability whatsoever relating to the choice, selection or use of the ST products and services described herein.

No license, express or implied, by estoppel or otherwise, to any intellectual property rights is granted under this document. If any part of this document refers to any third party products or services it shall not be deemed a license grant by ST for the use of such third party products or services, or any intellectual property contained therein or considered as a warranty covering the use in any manner whatsoever of such third party products or services or any intellectual property contained therein.

UNLESS OTHERWISE SET FORTH IN ST'S TERMS AND CONDITIONS OF SALE ST DISCLAIMS ANY EXPRESS OR IMPLIED WARRANTY WITH RESPECT TO THE USE AND/OR SALE OF ST PRODUCTS INCLUDING WITHOUT LIMITATION IMPLIED WARRANTIES OF MERCHANTABILITY, FITNESS FOR A PARTICULAR PURPOSE (AND THEIR EQUIVALENTS UNDER THE LAWS OF ANY JURISDICTION), OR INFRINGEMENT OF ANY PATENT, COPYRIGHT OR OTHER INTELLECTUAL PROPERTY RIGHT.

UNLESS EXPRESSLY APPROVED IN WRITING BY AN AUTHORIZED ST REPRESENTATIVE, ST PRODUCTS ARE NOT RECOMMENDED, AUTHORIZED OR WARRANTED FOR USE IN MILITARY, AIR CRAFT, SPACE, LIFE SAVING, OR LIFE SUSTAINING APPLICATIONS, NOR IN PRODUCTS OR SYSTEMS WHERE FAILURE OR MALFUNCTION MAY RESULT IN PERSONAL INJURY, DEATH, OR SEVERE PROPERTY OR ENVIRONMENTAL DAMAGE. ST PRODUCTS WHICH ARE NOT SPECIFIED AS "AUTOMOTIVE GRADE" MAY ONLY BE USED IN AUTOMOTIVE APPLICATIONS AT USER'S OWN RISK.

Resale of ST products with provisions different from the statements and/or technical features set forth in this document shall immediately void any warranty granted by ST for the ST product or service described herein and shall not create or extend in any manner whatsoever, any liability of ST.

ST and the ST logo are trademarks or registered trademarks of ST in various countries.

Information in this document supersedes and replaces all information previously supplied.

The ST logo is a registered trademark of STMicroelectronics. All other names are the property of their respective owners.

© 2010 STMicroelectronics - All rights reserved

STMicroelectronics group of companies

Australia - Belgium - Brazil - Canada - China - Czech Republic - Finland - France - Germany - Hong Kong - India - Israel - Italy - Japan - Malaysia - Malta - Morocco - Philippines - Singapore - Spain - Sweden - Switzerland - United Kingdom - United States of America

www.st.com