

NXP 74LVC169 demo board



Demonstrate a binary counter for high-speed counting applications

This compact demo board makes it easy to evaluate the 74LVC169, a binary counter with internal look-ahead carry circuitry for cascading in high-speed counting applications.

Key features and benefits

- ▶ 5 V tolerant inputs for interfacing with 5 V logic and use in 3/5 V mixed voltage applications
- ▶ Wide supply voltage range: 1.2 to 3.6 V
- ▶ CMOS low power consumption for portable applications
- ▶ Direct interface with TTL levels
- ▶ Up/down counting
- ▶ Two count enable inputs for n-bit cascading
- ▶ Built-in look-ahead carry capability
- ▶ Presetable for programmable operation
- ▶ Multiple extremely small standard and leadless packages
- ▶ Wide operating temperature range (-40 to +125 °C), suitable for industrial and automotive applications

Applications

- ▶ Portable devices
- ▶ Industrial
- ▶ Automotive

The 74LVC169 is a synchronous presetable 4-bit binary counter which features an internal look-ahead carry circuitry for cascading in high-speed counting applications. Synchronous operation is provided by having all flip-flops clocked simultaneously so that the outputs (pins Q0 to Q3) change simultaneously with each other when instructed by the count-enable (pins \overline{CEP} and \overline{CET}) inputs and internal gating. This mode of operation eliminates the output counting spikes that are normally associated with asynchronous (ripple clock) counters. A buffered clock (pin CP) input triggers the four flip-flops on the LOW-to-HIGH transition of the clock.

The counter is fully programmable; that is, the outputs may be preset to any number between 0 and its maximum count of 15. Presetting is synchronous with the clock and takes place regardless of the levels of the count enable inputs. A LOW level on the parallel enable (pin \overline{PE}) input disables the counter and causes the data at the Dn input to be loaded into the counter on the next LOW-to-HIGH transition of the clock. The direction of the counting is controlled by the up/down (pin U/\overline{D}) input. When pin U/\overline{D} is HIGH, the counter counts up, when LOW, it counts down.



The look-ahead carry circuitry is provided for cascading counters for n-bit synchronous applications without additional gating. Instrumental in accomplishing this function are two count-enable (pins $\overline{\text{CEP}}$ and $\overline{\text{CET}}$) inputs and a terminal count (pin $\overline{\text{TC}}$) output. Both count-enable (pins $\overline{\text{CEP}}$ and $\overline{\text{CET}}$) inputs must be LOW to count. Input pin $\overline{\text{CET}}$ is fed forward to enable the terminal count (pin $\overline{\text{TC}}$) output. Pin $\overline{\text{TC}}$ thus enabled will produce a LOW-level output pulse with a duration approximately equal to a HIGH level portion of pin Q0 output. The LOW level pin $\overline{\text{TC}}$ pulse is used to enable successive cascaded stages.

Schematics of 74LVC169 demo board are shown in figure below. A supply voltage of 1.2 to 3.6 V can be used for the board. In this design, the 74LVC169 is used as a clock divider that divides the main clock connected to CP pin by 2, 4, 8 and 16. By default, U/D pin is pulled low and $\overline{\text{PE}}$ pin is pulled HIGH, so counter starts counting down, when clock input edge goes from LOW to HIGH.

The main clock, when connected to the CP pin, is divided by 2 and appears at the Q0 output. There is a clock with 1/4 the frequency of the main clock at Q1. Clocks with 1/8 and 1/16 of main frequency are available at Q2 and Q3 output pins respectively.

In order to preset the outputs of the counter to a number between 0 and its maximum count, the $\overline{\text{PE}}$ pin can be pulled LOW by using jumper JP1. Data at Dn inputs can now be loaded to the outputs on next LOW-to-HIGH transition of main clock. Also, U/D pin can be pulled HIGH by providing logic high input at pin 1 of P1 connector to count up instead of counting down. Since $\overline{\text{CET}}$ pin is pulled LOW, when counter reaches terminal count (HHHH in count up mode and LLLL in count down mode), $\overline{\text{TC}}$ output, which is normally HIGH, will go LOW. The low level on $\overline{\text{TC}}$ output can be used to enable successive cascaded devices

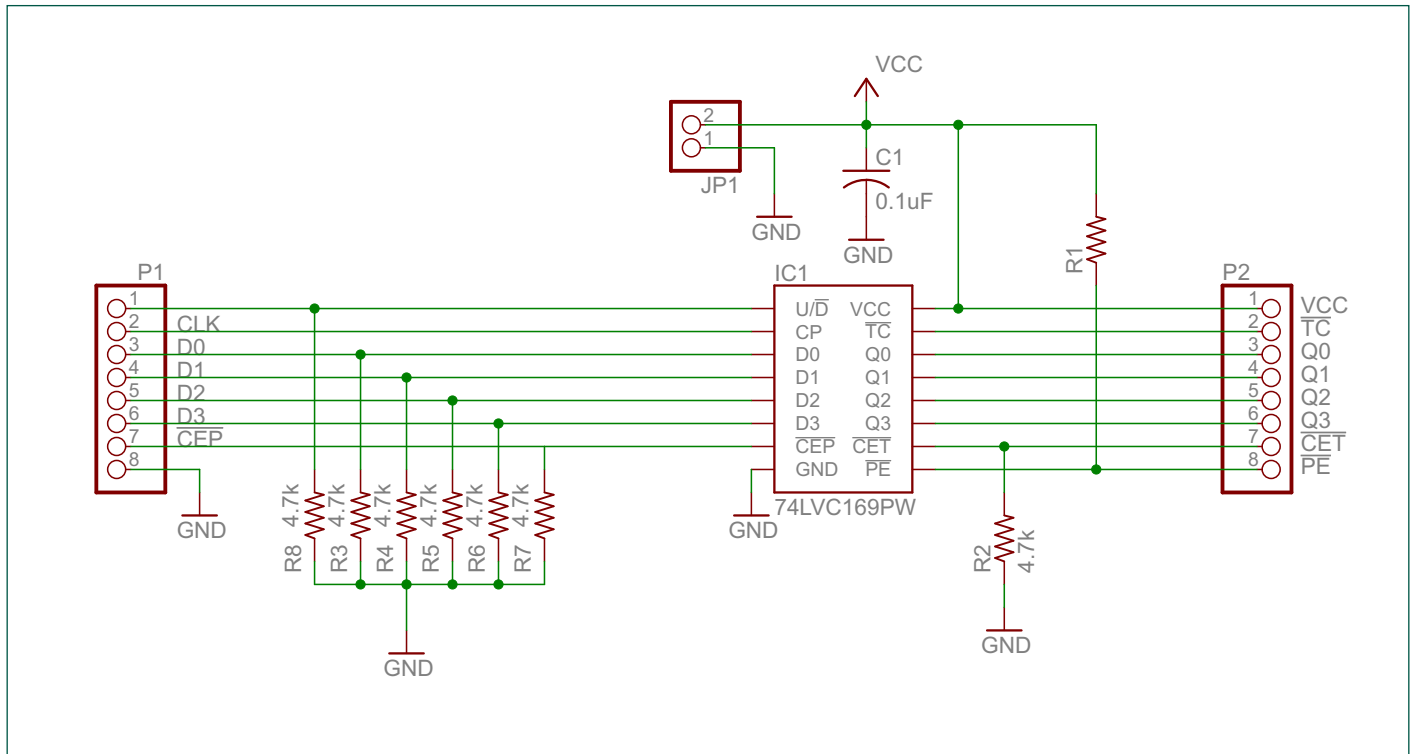

Circuit schematic of 74LVC169 demo board

Test results

Figure 1 shows a main clock of 466 kHz in green at CP input and a divided-by-2 clock output of 233 kHz in purple at Q0 pin. By default \overline{PE} pin is pulled up to V_{CC} and U/\overline{D} pin is pulled down to GND. Figure 2 shows a main clock of 500 kHz in green at CP input. The Q1 output shows a divided-by-4 clock of

approximately 166 kHz in purple. In this case, U/\overline{D} pin is pulled up so counter starts counting up on rising edge of input clock. Similarly, Figures 3 and 4 show the clock outputs of 71 and 33 kHz, which are approximately 1/8 and 1/16 of main clock respectively. Since U/\overline{D} is pulled LOW for clock output in these examples, counter is counting down.



Figure 1



Figure 2



Figure 3



Figure 4

Packages

74LVC169 is available in 16-pin SO, SSOP, TSSOP and leadless DQFN packages.

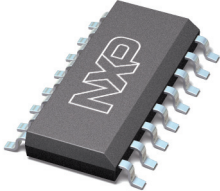
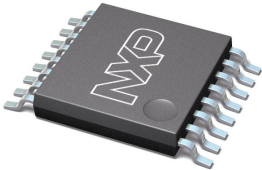
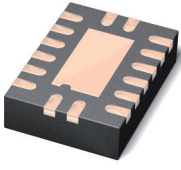
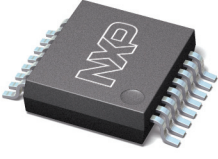
Package suffix	D	PW	BQ	DS
				
	SOT109-1	SOT403-1	SOT763-1	SOT338-1
	16-pin	16-pin	16-pin	16-pin
Width (mm)	6.0	6.4	2.5	7.75
Length (mm)	9.9	5.0	3.5	6.2
Pitch (mm)	1.27	0.65	0.5	0.65

Ordering information

Part number	Package				
	Temp. range	Name	Type	Marking	Material
74LVC169	-40 to 125 °C	SO16	Small outline	74LVC169D	Plastic
74LVC169DB	-40 to 125 °C	SSOP16	Shrink small outline	LVC169	Plastic
74LVC169PW	-40 to 125 °C	TSSOP16	Thin shrink small outline	LVC169	Plastic
74LVC169BQ	-40 to 125 °C	DHVQFN16	Dual in-line compatible thermal enhanced very thin quad flat package with no leads	LVC169	Plastic