

## A 36W Ballast Application with the NCP5104

Prepared by: Thierry Sutto



ON Semiconductor®

<http://onsemi.com>

This document describes how the NCP5104 driver can be implemented in a ballast application. The scope of this application note is to highlight the NCP5104 driver and not to explain or detailed how to build electronic ballast.

The NCP5104 is a high voltage power MOSFET driver providing two outputs for direct drive of 2 N-channel power MOSFETs arranged in a half-bridge configuration with only one input.

It uses the bootstrap technique to insure a proper drive of the High-side power switch. The driver works with one input to accommodate half-bridge topology with a fixed dead time of 520 ns.

### Demo Board Specification

- Input range : 85 Vac - 145 Vac OR 184 Vac - 265 Vac
- Ballast Output Power : 36 W (type PL-L 36W)
- Pre-Heating Current : 295 mA
- Pre-Heating Time : 1 second
- Nominal Current : 414 mA

**NOTE: BEFORE PLUGGING IN THE DEMO BOARD, MAKE SURE THE JUMPER IS ON THE CORRECT POSITION: IF J2 IS USED, THEN  $V_{in}$  MUST BE LOWER THAN 145 Vac.**

### Detailed Operation

The lamp ballast is powered via a half bridge configuration. The 2 power MOSFETs are driven with the NCP5104 driver. The driver is supplied by the  $V_{CC}$  rail, and the high side driver is supplied by the bootstrap diode: when the low side power MOSFET (Q2) is switched ON, the BRIDGE pin is pulled down to the ground, thus the capacitor connected between BRIDGE pin and VBOOT pin is refuelled via the diode D3 and the resistor R5 connected to  $V_{CC}$ . When Q2 is switched OFF the bootstrap capacitor C6 supplies the high side driver with a voltage equal to  $V_{CC}$  level minus the D3 forward voltage diode. Given the NCP5104 architecture, the driver copies the input signal to the high side driver, then it generates a fixed dead time (520 ns) before toggling the low side driver when the input pin level changes.

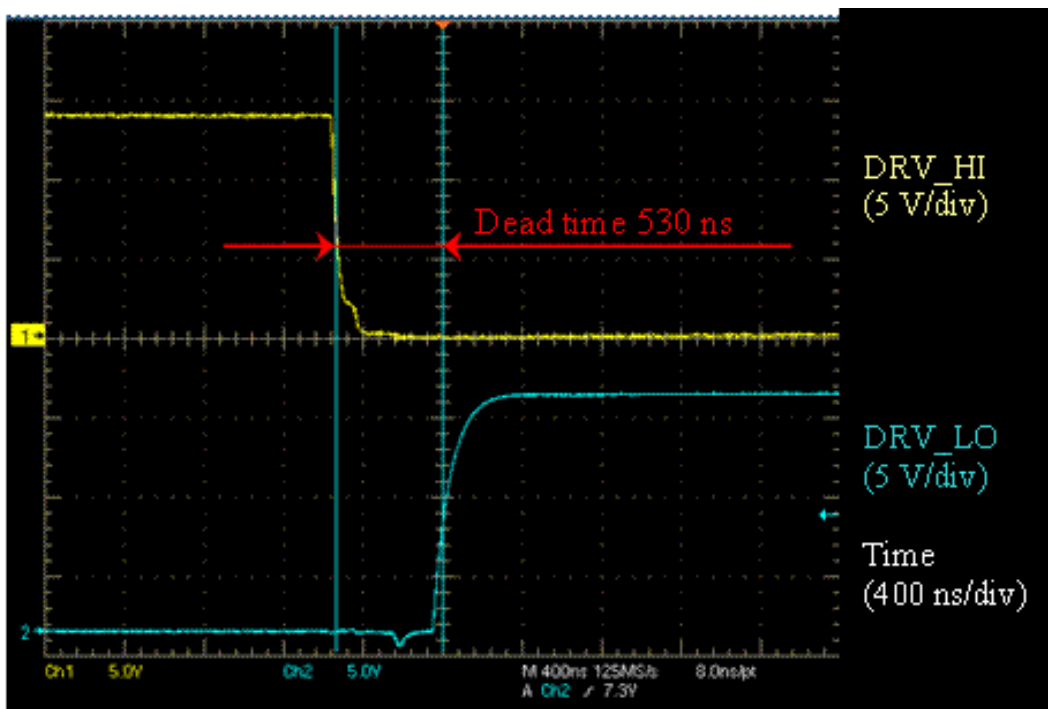

Figure 1. Dead Time Between the High and Low-Side Driver

# AND8312/D

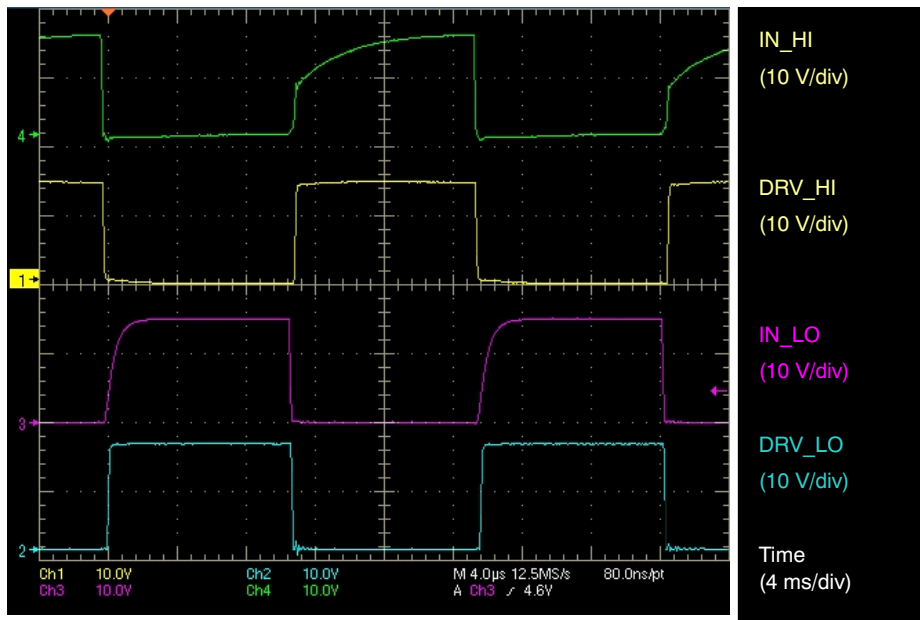

Figure 2. Input Output Timing Diagram

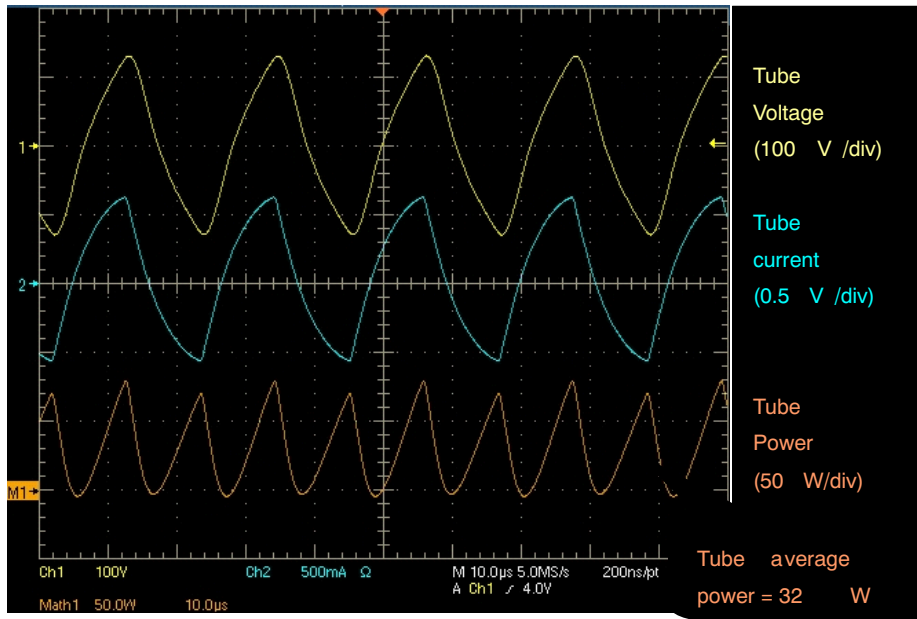

Figure 3. Tube Signals

# AND8312/D

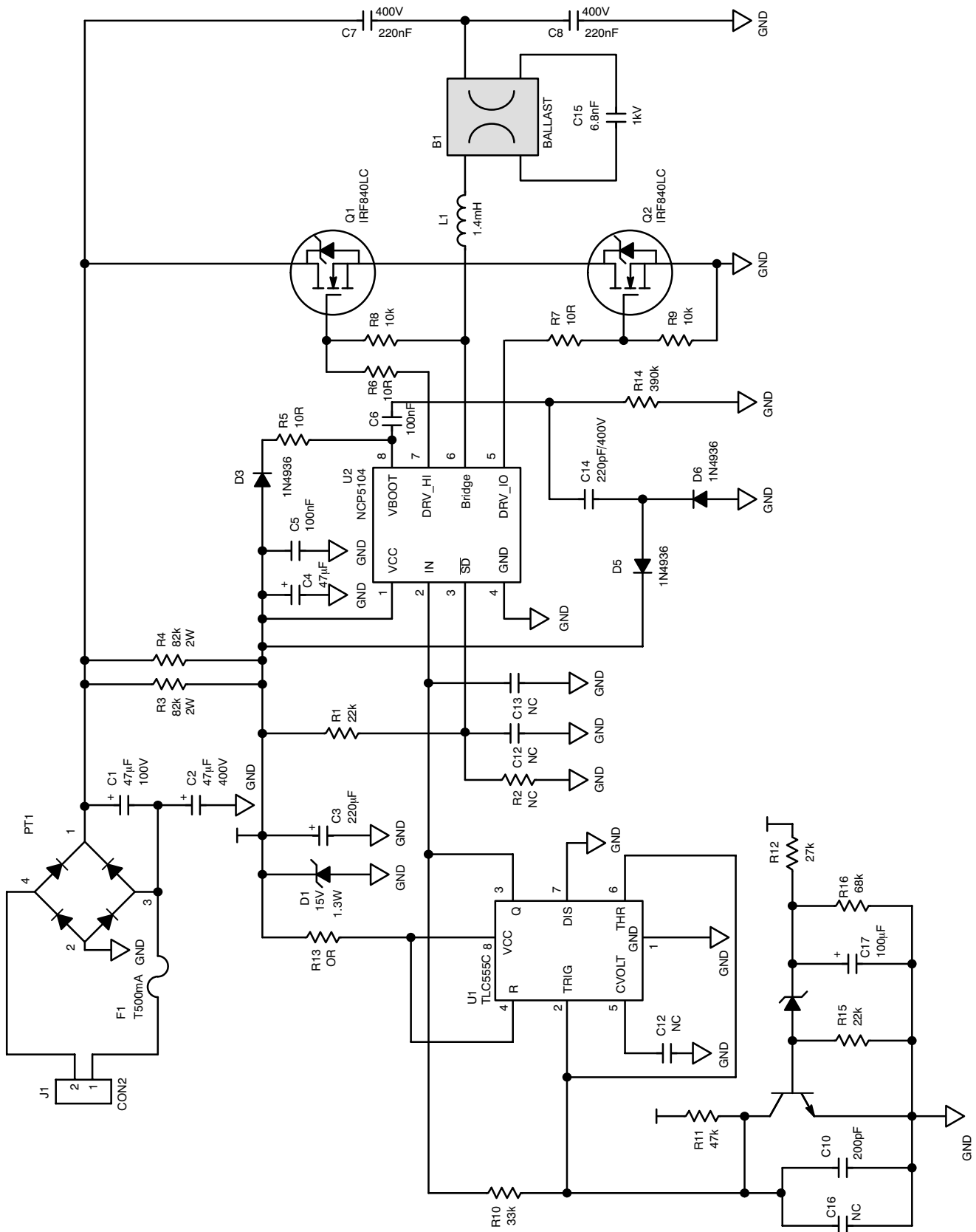

Figure 4. Demo Board Schematic

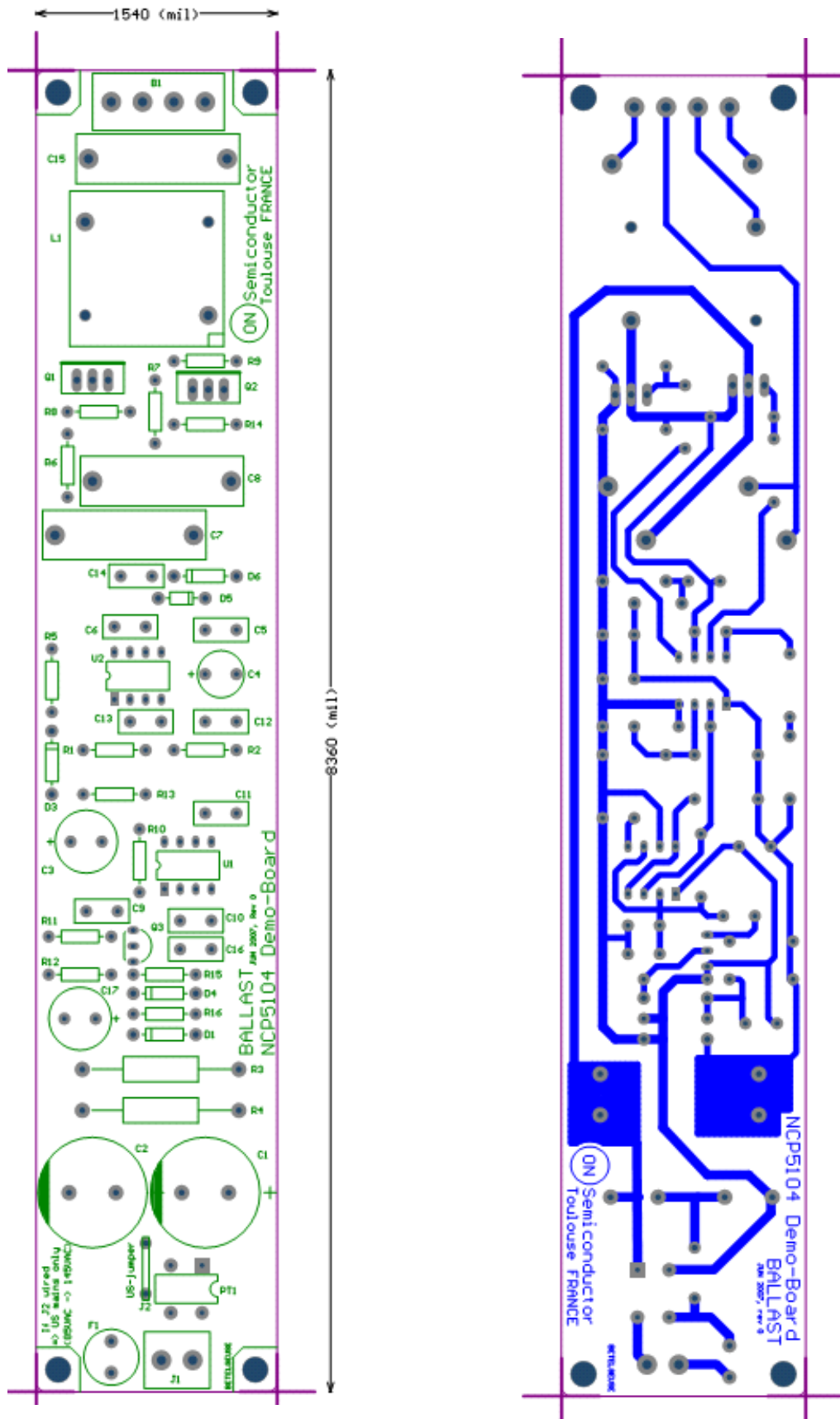

Figure 5. PCB Printout: Top and Bottom View

## AND8312/D

### BILL OF MATERIAL

Part Type	Designator	Manufacturer	Description
Connector	B1, J1	-	Connector
47uF/400V	C1, C2	Panasonic	M Series
220pF	C10	Generic	Capacitor
10nF	C11	Generic	Capacitor
NC	C12, C13	-	Capacitor
220pF /400V	C14	Generic	Capacitor
6.8nF/1kV	C15	Generic	Capacitor
NC	C16	-	Capacitor
100uF	C17	Generic	Capacitor
220uF	C3	Generic	Capacitor
4.7uF/50V	C4	Generic	Capacitor
100nF	C5	Generic	Capacitor
100nF	C6	Generic	Capacitor
220nF/400V	C7, C8	Generic	Capacitor
220pF	C9	Generic	Capacitor
BZX85C15V	D1	Generic	15V Zener diode
1N4936	D3, D5, D6	ON Semiconductor	Fast Recovery rectifier
BZX85C5V1	D4	Generic	5V1 Zener diode
T500mA	F1	Generic	Fuse
US-jumper	J2	-	Jumper for US main supply only
1.4mH	L1	VOGT	VOGT 53-044
DF06M	PT1	-	600V Diode Bridge
IRF840LC	Q1, Q2	IRF	Low Charge N-Channel MOSFET
BC547B	Q3	Generic	NPN transistor
22k	R1	Generic	Resistor
33k	R10	Generic	Resistor
47k	R11	Generic	Resistor
27k	R12	Generic	Resistor
15k	R13	Generic	Resistor
390k	R14	Generic	Resistor
22k	R15	Generic	Resistor
68k	R16	Generic	Resistor
NC	R2	-	Resistor
82k/2W	R3, R4	Generic	Resistor 2W power type
10R	R5, R6, R7	Generic	Resistor
10k	R8, R9	Generic	Resistor
TLC555C	U1	Texas Instrument	CMOS 555 timer
NCP5104	U2	ON Semiconductor	NCP5104

**ON Semiconductor** and **ON** are registered trademarks of Semiconductor Components Industries, LLC (SCILLC). SCILLC reserves the right to make changes without further notice to any products herein. SCILLC makes no warranty, representation or guarantee regarding the suitability of its products for any particular purpose, nor does SCILLC assume any liability arising out of the application or use of any product or circuit, and specifically disclaims any and all liability, including without limitation special, consequential or incidental damages. "Typical" parameters which may be provided in SCILLC data sheets and/or specifications can and do vary in different applications and actual performance may vary over time. All operating parameters, including "Typicals" must be validated for each customer application by customer's technical experts. SCILLC does not convey any license under its patent rights nor the rights of others. SCILLC products are not designed, intended, or authorized for use as components in systems intended for surgical implant into the body, or other applications intended to support or sustain life, or for any other application in which the failure of the SCILLC product could create a situation where personal injury or death may occur. Should Buyer purchase or use SCILLC products for any such unintended or unauthorized application, Buyer shall indemnify and hold SCILLC and its officers, employees, subsidiaries, affiliates, and distributors harmless against all claims, costs, damages, and expenses, and reasonable attorney fees arising out of, directly or indirectly, any claim of personal injury or death associated with such unintended or unauthorized use, even if such claim alleges that SCILLC was negligent regarding the design or manufacture of the part. SCILLC is an Equal Opportunity/Affirmative Action Employer. This literature is subject to all applicable copyright laws and is not for resale in any manner.

## PUBLICATION ORDERING INFORMATION

### LITERATURE FULFILLMENT:

Literature Distribution Center for ON Semiconductor  
P.O. Box 5163, Denver, Colorado 80217 USA  
**Phone:** 303-675-2175 or 800-344-3860 Toll Free USA/Canada  
**Fax:** 303-675-2176 or 800-344-3867 Toll Free USA/Canada  
**Email:** [orderlit@onsemi.com](mailto:orderlit@onsemi.com)

**N. American Technical Support:** 800-282-9855 Toll Free  
USA/Canada  
**Europe, Middle East and Africa Technical Support:**  
Phone: 421 33 790 2910  
**Japan Customer Focus Center**  
Phone: 81-3-5773-3850

**ON Semiconductor Website:** [www.onsemi.com](http://www.onsemi.com)  
**Order Literature:** <http://www.onsemi.com/orderlit>  
For additional information, please contact your local  
Sales Representative