



DTMF DECODER KIT USER'S GUIDE

1. Kit Contents

The DTMF Decoder Reference Design Kit includes the following items:

- DTMF Decoder Evaluation Board.
- Universal (100–240 V, 50–60 Hz) AC to DC Power Adapter.
- DTMF Decoder Kit User's Guide (this document).
- Reference Design CD containing the following items:
 - DTMF Decoder Reference Design (AN218) and associated software (AN218SW.zip).
 - Keil Software 8051 Development Tools (evaluation assembler, 2 kB limited compiler, and linker).
 - All DTMF Decoder related documentation in PDF format.

2. DTMF Decoder Overview

The DTMF Decoder Evaluation Board contains both a DTMF Decoder and DTMF Generator. The evaluation board provides a hardware platform for evaluating the software provided in the DTMF Decoder Reference Design and prototyping telephony applications using the C8051F300 MCU. The DTMF Decoder Evaluation board is shown in Figure 1.

The DTMF Decoder Reference Design (available on the CD) includes the following:

- Background and theory of DTMF decoding using the Goertzel Algorithm.
- Description of a software implementation for the C8051F300 MCU.
- Full C source code for the DTMF decoder and generator. The software is available on the Reference Design Kit CD (AN218SW.zip) and on the [Silicon Laboratories website](http://www.siliconlabs.com).

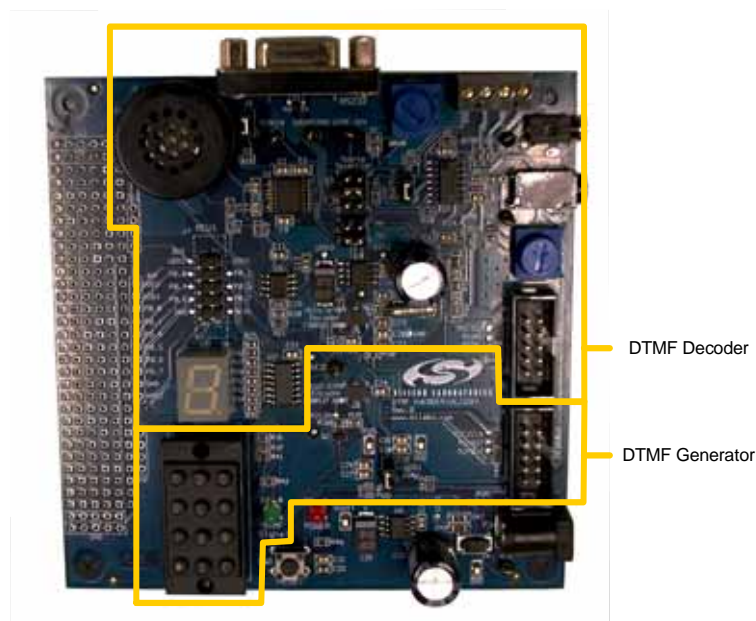

Figure 1. DTMF Decoder Evaluation Board

DTMF-RD

2.1. DTMF Decoder

The DTMF decoder section of the evaluation board can accept DTMF signals from three input sources as shown in Figure 2. The Audio Jack input source allows direct connection to a PC sound card and accepts bi-polar signals from the sound card. This allows DTMF tones to be recorded and played back from a .WAV file or generated using DTMF generation software. The bi-polar signal is converted to a uni-polar signal and conditioned before being routed to the MCU's ADC input. The user should adjust the gain and offset potentiometers such that the conditioned signal at the ADC input varies between 0 to 3 V.

The second input source, labeled *DTMF_Gen*, selects the output of the on-board DTMF Generator as the input to the DTMF decoder. See "DTMF Generator" on page 2 for more details about the on-board DTMF Generator. The third input source, *Terminal Block*, allows a stand-alone signal generator to be used for generating DTMF signals. This input is fed directly to the ADC input; therefore, the signal levels on this uni-polar input must be between 0 and 3 V.

The selected input signal is routed to the MCU's ADC input and to an amplified speaker and audio jack for listening to the input DTMF tones. Once a valid DTMF tone is detected by the decoder, the corresponding symbol is displayed on the 7-Segment LED and printed to a UART terminal.

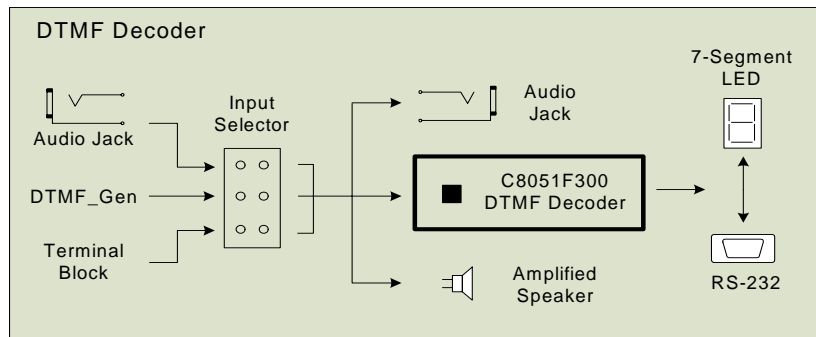

Figure 2. Demo Board (Decoder Section)

2.2. DTMF Generator

Figure 3 shows a block diagram of the DTMF Generator section of the demo board. As buttons on the keypad are pressed, DTMF tones are generated by the C8051F300. A 100 ms tone is generated for each key press. The MCU generates a digital signal corresponding to the DTMF code using the PCA. The digital signal is passed through a low pass filter to remove the high-frequency components and allow only pure tones to be passed to the output.

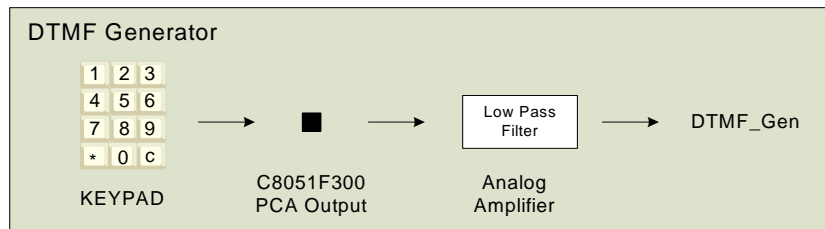

Figure 3. Demo Board (Generator Section)

3. DTMF Demonstration

The DTMF Decoder Evaluation Board is factory pre-programmed with both the DTMF decoder and generator firmware. For this demonstration, connect the output of the DTMF generator to the input of the DTMF decoder.

1. Verify that J10 (next to the red LED) is shorted. This supplies power to the decoder section of the board.
2. Verify that pins 3 and 4 (the middle pins) of J4 are shorted. The J4 header is near the RS-232 connector and is labeled "Source Selection".
3. Verify that J3 is shorted. The J3 header is located near the speaker and may be removed to disconnect the speaker.
4. Power the DTMF Decoder Evaluation Board using the supplied 9 V ac adapter. You should hear the speaker beep and the decimal point on the 7-segment LED should be displayed.
5. Press any key on the keypad. This generates a DTMF tone. When the DTMF tone is detected by the decoder, it will be displayed on the 7-segment LED.

To view the decoded characters on a UART Terminal:

1. Verify that pins 1 and 2 of J6 are shorted. This enables UART transmission.
2. Connect a UART terminal to the RS-232 connector using a serial cable.
3. Configure the terminal for 9600 Baud 8-N-1.
4. The characters should be printed to the terminal as buttons on the keypad are pressed.

4. Updating Firmware

If the DTMF Decoder Evaluation Board is used to develop software for the C8051F300, the original firmware can be restored by downloading the HEX files provided in the AN218.zip file. A USB Debug Adapter or Serial Debug Adapter is required to download the hex files. A USB Debug Adapter is included in the C8051F300 Development Kit. See the [Silicon Laboratories website](#) for more details.

Note: The evaluation compiler included on the Reference Design CD is limited to 2 kB object code generation. The evaluation compiler included on the Development Kit CD is limited to 4 kB object code generation. The DTMF Decoder example software has an object code size of 3866 bytes when compiled at optimization level 9. The Development Kit CD is included in each Silicon Laboratories Development Kit and can also be ordered from the [Silicon Laboratories website](#) as a separate item.



5. Schematic

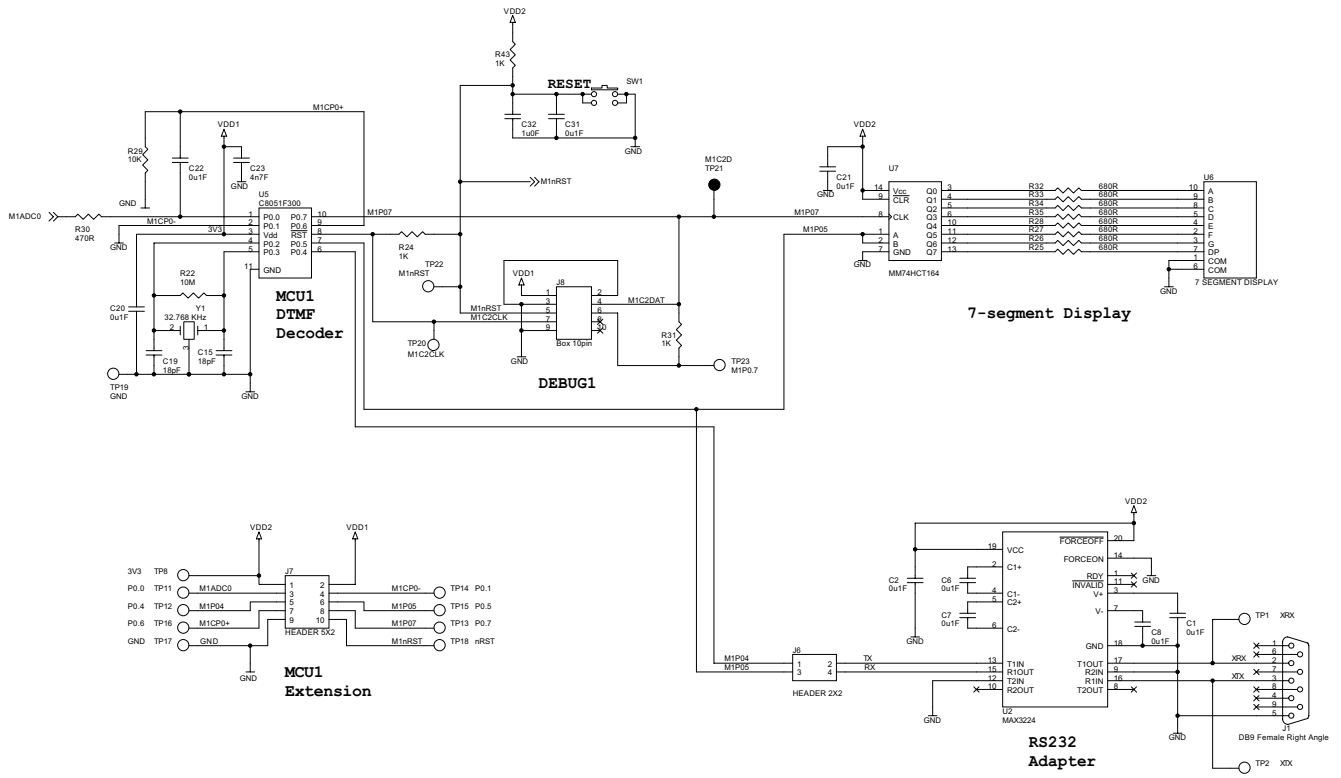

Figure 4. DTMF Decoder Evaluation Board (Schematic 1 of 4)

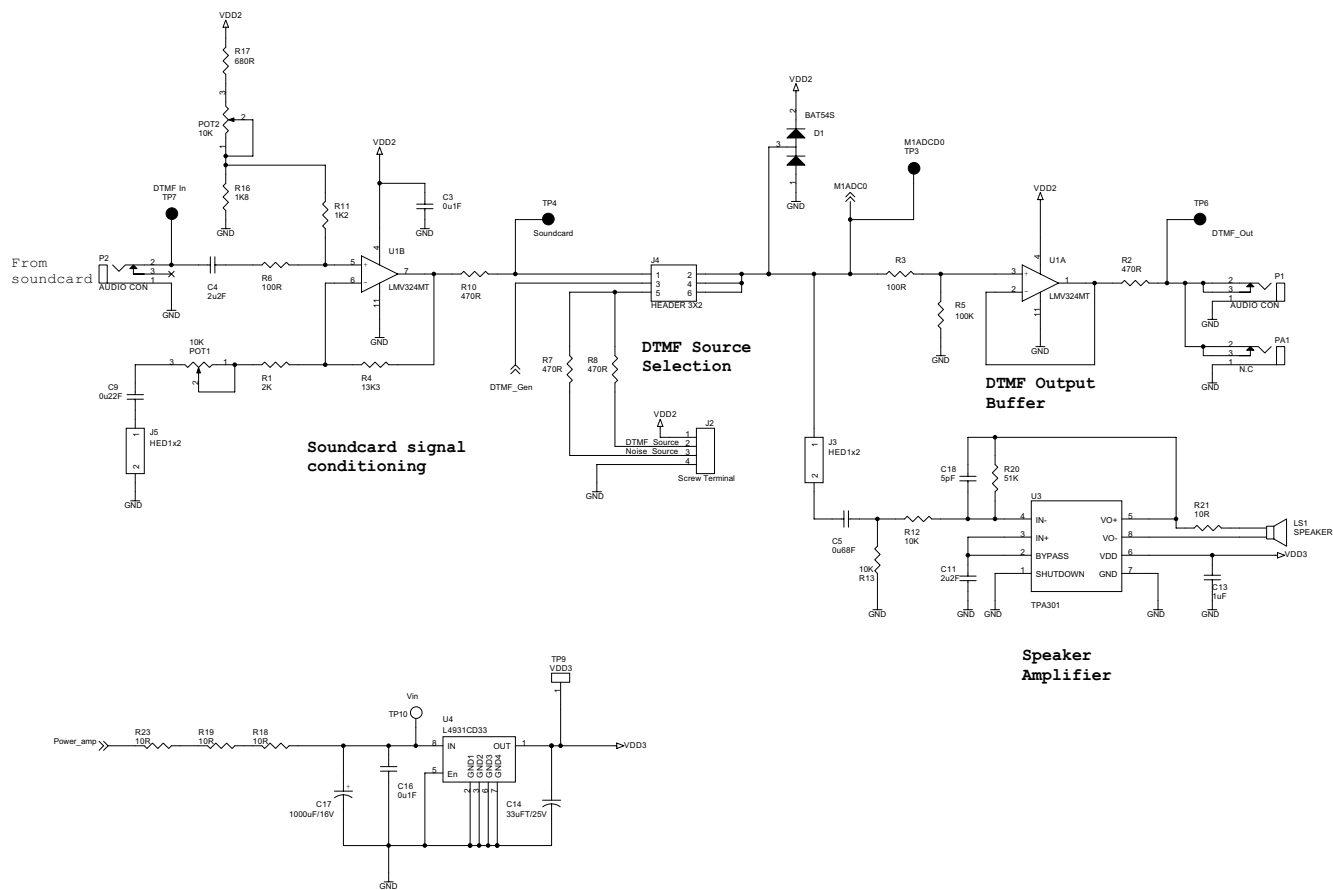

Figure 5. DTMF Decoder Evaluation Board (Schematic 2 of 4)



DTMF-RD

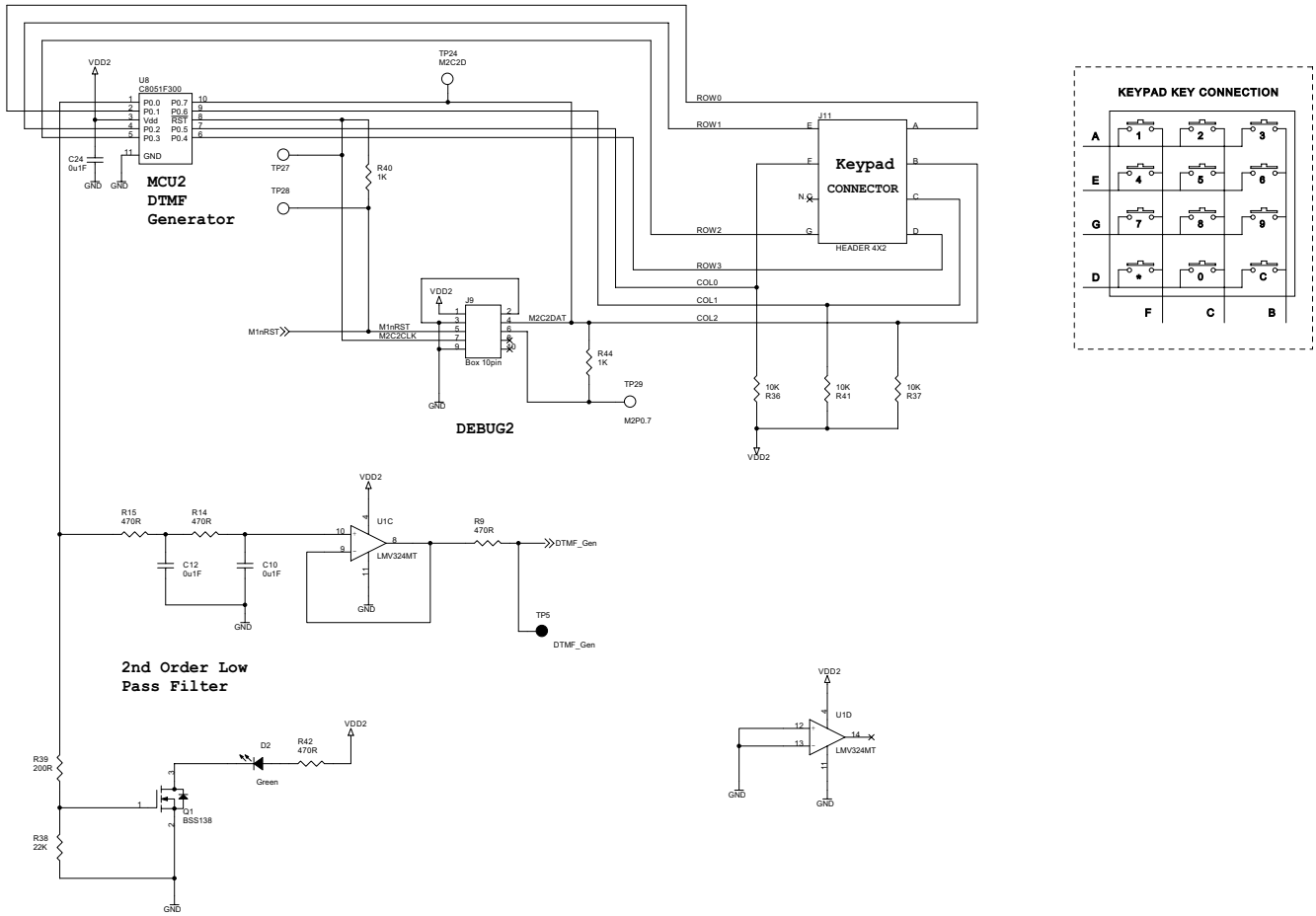

Figure 6. DTMF Decoder Evaluation Board (Schematic 3 of 4)

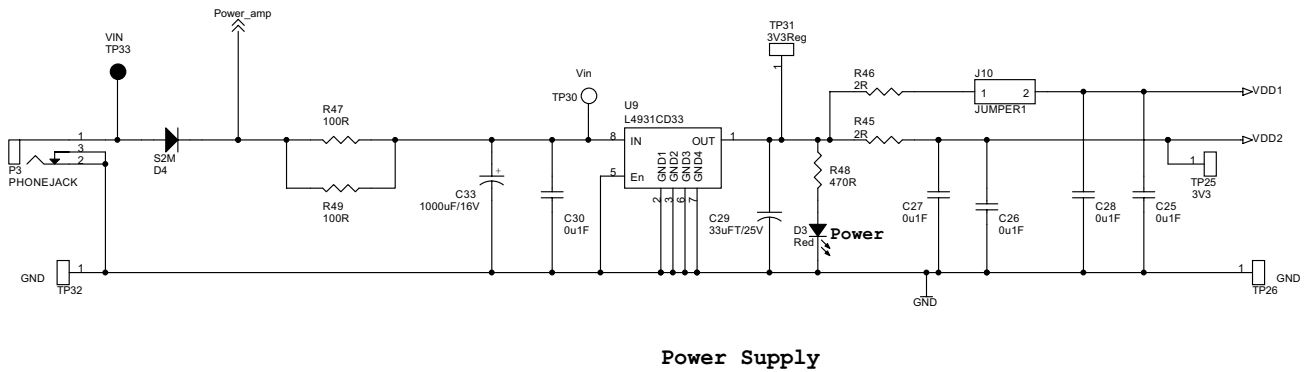

Figure 7. DTMF Decoder Evaluation Board (Schematic 4 of 4)

NOTES:



CONTACT INFORMATION

Silicon Laboratories Inc.

4635 Boston Lane
Austin, TX 78735
Email: MCUinfo@silabs.com
Internet: www.silabs.com

The information in this document is believed to be accurate in all respects at the time of publication but is subject to change without notice. Silicon Laboratories assumes no responsibility for errors and omissions, and disclaims responsibility for any consequences resulting from the use of information included herein. Additionally, Silicon Laboratories assumes no responsibility for the functioning of undescribed features or parameters. Silicon Laboratories reserves the right to make changes without further notice. Silicon Laboratories makes no warranty, representation or guarantee regarding the suitability of its products for any particular purpose, nor does Silicon Laboratories assume any liability arising out of the application or use of any product or circuit, and specifically disclaims any and all liability, including without limitation consequential or incidental damages. Silicon Laboratories products are not designed, intended, or authorized for use in applications intended to support or sustain life, or for any other application in which the failure of the Silicon Laboratories product could create a situation where personal injury or death may occur. Should Buyer purchase or use Silicon Laboratories products for any such unintended or unauthorized application, Buyer shall indemnify and hold Silicon Laboratories harmless against all claims and damages.

Silicon Laboratories and Silicon Labs are trademarks of Silicon Laboratories Inc.

Other products or brandnames mentioned herein are trademarks or registered trademarks of their respective holders.