

Evaluation Kit for MSA240KC and MSA260KC

INTRODUCTION

This easy-to-use kit provides a platform for the evaluation of PWM circuits using the MSA240KC/260KC pin out. With ample bread boarding areas it is flexible enough to analyze a multitude of standard or proprietary circuit configurations. Critical connections for power supply bypassing are pre-wired. Components not usually readily available in engineering labs are provided. External connection to the evaluation kit can be made via the terminal block and banana jacks at the edges of the circuit board.

BEFORE YOU GET STARTED

- All Apex Precision Power amplifiers should be handled using proper ESD precautions.
- Do not change connections while the circuit is powered.
- Initially set all power supplies to the minimum operating voltage allowed in the device data sheet.

PARTS LIST

Ref	Apex Part No.	Description/Vendor	Qty
NA	HS28	Heat Sink, Apex Precision Power	2
NA	HS26	Heat Sink, Apex Precision Power	1
NA	MS11	30-pin socket carrier strip	2
NA	EVAL56	PC Board	1
NA	60SPG00004	Spacer Grommets/ Micro Plastics	4
BJ1-4	BJ1	Banana Jack/ Deltron 164-6218	4
C1,3	ZX7R105KTL	1uf 500V Cap/ Novacap	2
For identification note this capacitor has "legs":			
C2*	EC05	2200uF 100V/ United Chemi-Con 82DA222M100KC2D	1
C2*	EC06	470uF 450V/ United Chemi-Con KMH450VN471M35X50T2	1
TS1	TS02	Terminal Strip	1
R1,2*	CSR22	0.020Ω Resistor/ Isotek PBV-R020-1	2
R1,2*	CSR20	0.010Ω Resistor/ Isotek PBV-R010-1	2
R1,2*	CSR21	0.015Ω Resistor/2 Isotek PBV-R015-1	2

*Chosen per directions

ASSEMBLY

During assembly refer to Figure 1 and the data sheet for the product you are using, either the MSA240KC or MSA260KC. 1. Note that each side of the circuit board is identified as either the component side or "DUT side".

- Two 30-pin socket strips have been supplied with this kit that have been loaded with cage jacks. Using wire cutters trim the carrier to remove two sockets from one of the strips. Insert the socket strips from the "DUT side" of the board and solder the jacks from the "component side" of the board, making sure that each socket strip is fully seated before soldering. After soldering the jacks remove and discard the plastic carrier.
- Solder the surface mount capacitors at C1 and C3 on the "component side" of the board.
- From the "component side" mount banana jacks at BJ1-4 and solder from the "DUT Side" of the circuit board. Cut off excess lead lengths. Note that BJ1 is connected to SIG GND.
- Several low ohm value resistors are provided with this evaluation kit: 0.020Ω, 0.015Ω and 0.010Ω. These are used to implement current limiting in the output circuit. Select the value most appropriate for your application. Refer to the product data sheet to determine which resistor value you should use.
- From the "component side" of the PCB mount the HS28 heat sink closest to C2 (to be added later) and solder the mounting tabs of the heat sink from the "DUT side" with a high capacity soldering iron.
- Apply a thin layer of thermal grease on the back of the chosen current limiting sense resistor R2 and insert the resistor into the PCB. Mount the resistor to the HS28 heat sink using #4 screw and nut hardware (not supplied). Place the screw into the mounting hole from the narrow-channel side of the heat sink and place the nut on the screw from the wide-channel side of the heat sink. Do not over tighten the screw. Finally, solder the resistor terminals to the PCB and **cut off the excess lead length.**
- Mount the remaining HS28 heat sink similarly to step 6.
- Repeat step 7 for R1 and the second HS28 heat sink.
- Mount the electrolytic capacitor at C2 from the "component side" of the PCB. Match the polarity markings on the capacitor with the polarity markings on the PCB. Use the correct voltage capacitors for the product you are using: A 100V capacitor for the MSA240KC, or a 450V capacitor for the MSA260KC. Be sure the capacitors have snapped into the PCB and solder from the "DUT side" of the PCB. Be sure to fill the holes with solder.
- Mount the terminal strip to the "component side" of the PCB. Make sure the terminal strip is fully seated and solder the pins from the "DUT side" of the PCB. Be sure to fill the mounting holes with solder.
- Mount a BNC connector (not supplied) to the PCB at location 5 (near the banana jacks) if desired. The body of the BNC connector is tied to SIG GND.
- Mount other components to complete your application circuit using the pads and holes provided. Refer to the data sheet for your model and note on page 4 that:

$$R_{RAMP} = 2 \times R_{OSC}$$

It is therefore convenient to use 3 resistors of equal value and make up R_{RAMP} from two of those resistors. Note on the PCB locations for R_{RAMP1} and R_{RAMP2} to do this.

ASSEMBLY CONT.

14. From the "DUT side" of the PCB snap the spacer-grommets into the holes at the four corners of the PCB. Notice that the holes are slightly rectangular and match the spacer-grommet's long and short sides to the holes in the PCB.
15. Apply a thin, uniform layer of thermal grease to the amplifier; a straight edge may be useful here. Position the amplifier over the mounting holes in the heatsink. Firmly push the amplifier onto the heatsink while slightly rotating the amplifier back and forth, ending with the mounting holes of the amplifier over the mounting holes in the heatsink.
16. Attach the amplifier to the heatsink with 4-40x½" male-female hex spacers (not supplied). These spacers serve as alignment pins and aide in the assembly of the PCB to the heatsink. Alternatively, use 4-40x¼" machine screws to mount the amplifier to the heatsink. Do not over-tighten the spacers or screws as this provides no thermal benefit and may break the hardware.
17. Place the PCB assembly on the heatsink/amplifier assembly so that the hex spacers come through the aligning holes near the corners of the amplifier location in the PCB. Carefully lower the PCB assembly until the pins of the amplifier engage the cage jacks. Alternately, sight through the aligning holes in the PCB and match-up the PCB to the screws used to mount the amplifier. In either case be sure the pins of the amplifier are engaged with the cage jacks and then continue pushing the PCB assembly in the area between the amplifier's pins until the four spacer grommets at the four corners of the PCB touch the heatsink. At this point the PCB should not be bowed.
18. Using #8 X 1" sheet metal screws (not provided) mount the PCB to the heat sink at the four spacer-grommets.
19. Hook up power and signals as necessary. The amplifier is now ready for testing.

FIGURE 1: SCHEMATIC DIAGRAM

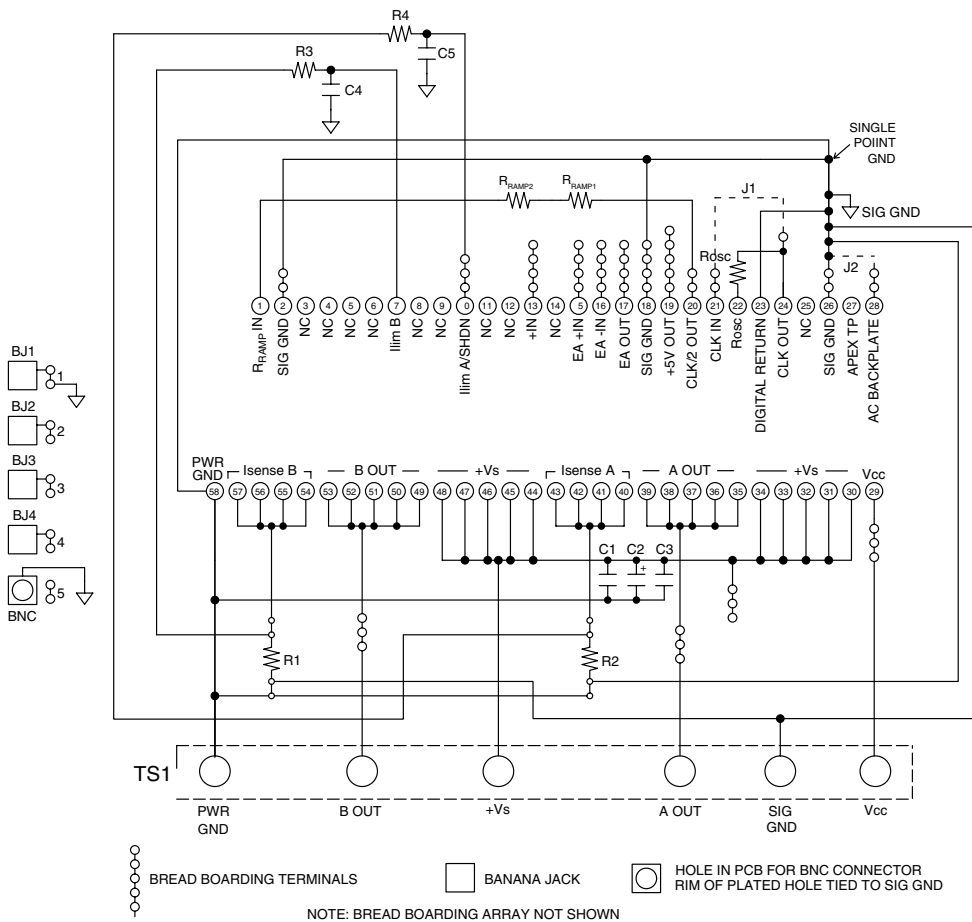

FIGURE 2:

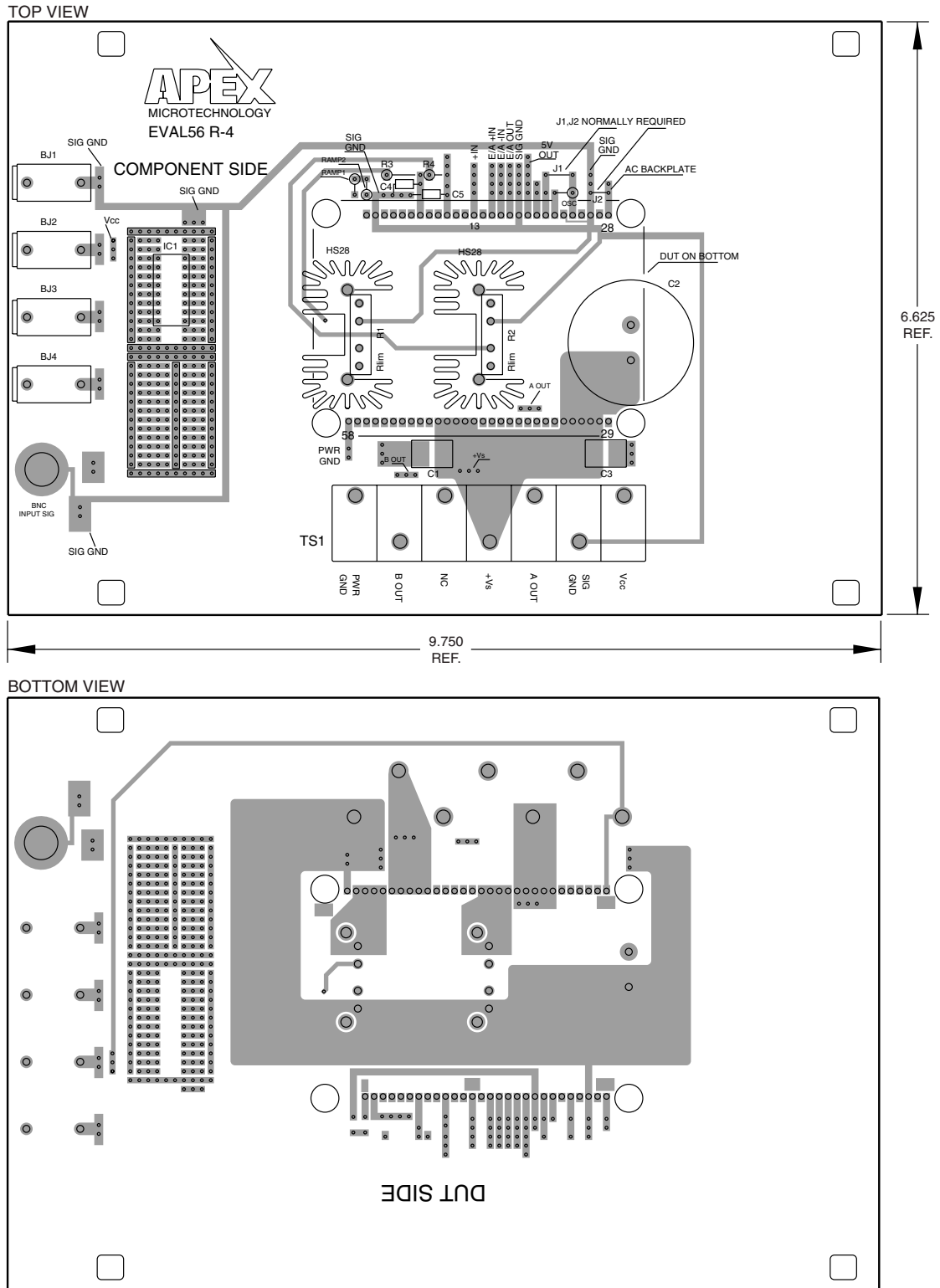
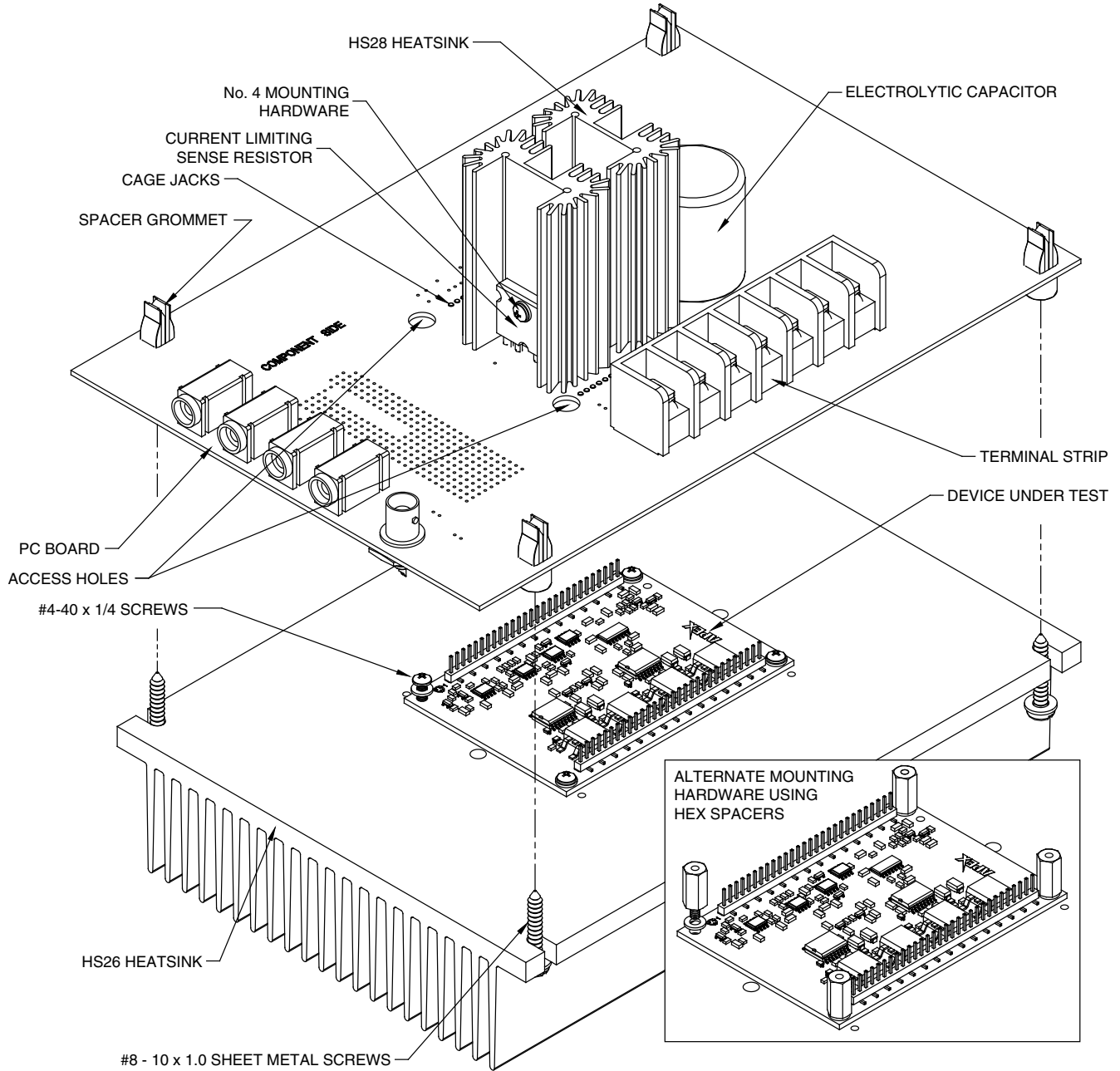

FIGURE 3:





CONTACTING CIRRUS LOGIC SUPPORT

For all Apex Precision Power product questions and inquiries, call toll free 800-546-2739 in North America.

For inquiries via email, please contact apex.support@cirrus.com.

International customers can also request support by contacting their local Cirrus Logic Sales Representative.

To find the one nearest to you, go to www.cirrus.com

IMPORTANT NOTICE

Cirrus Logic, Inc. and its subsidiaries ("Cirrus") believe that the information contained in this document is accurate and reliable. However, the information is subject to change without notice and is provided "AS IS" without warranty of any kind (express or implied). Customers are advised to obtain the latest version of relevant information to verify, before placing orders, that information being relied on is current and complete. All products are sold subject to the terms and conditions of sale supplied at the time of order acknowledgment, including those pertaining to warranty, indemnification, and limitation of liability. No responsibility is assumed by Cirrus for the use of this information, including use of this information as the basis for manufacture or sale of any items, or for infringement of patents or other rights of third parties. This document is the property of Cirrus and by furnishing this information, Cirrus grants no license, express or implied under any patents, mask work rights, copyrights, trademarks, trade secrets or other intellectual property rights. Cirrus owns the copyrights associated with the information contained herein and gives consent for copies to be made of the information only for use within your organization with respect to Cirrus integrated circuits or other products of Cirrus. This consent does not extend to other copying such as copying for general distribution, advertising or promotional purposes, or for creating any work for resale.

CERTAIN APPLICATIONS USING SEMICONDUCTOR PRODUCTS MAY INVOLVE POTENTIAL RISKS OF DEATH, PERSONAL INJURY, OR SEVERE PROPERTY OR ENVIRONMENTAL DAMAGE ("CRITICAL APPLICATIONS"). CIRRUS PRODUCTS ARE NOT DESIGNED, AUTHORIZED OR WARRANTED TO BE SUITABLE FOR USE IN PRODUCTS SURGICALLY IMPLANTED INTO THE BODY, AUTOMOTIVE SAFETY OR SECURITY DEVICES, LIFE SUPPORT PRODUCTS OR OTHER CRITICAL APPLICATIONS. INCLUSION OF CIRRUS PRODUCTS IN SUCH APPLICATIONS IS UNDERSTOOD TO BE FULLY AT THE CUSTOMER'S RISK AND CIRRUS DISCLAIMS AND MAKES NO WARRANTY, EXPRESS, STATUTORY OR IMPLIED, INCLUDING THE IMPLIED WARRANTIES OF MERCHANTABILITY AND FITNESS FOR PARTICULAR PURPOSE, WITH REGARD TO ANY CIRRUS PRODUCT THAT IS USED IN SUCH A MANNER. IF THE CUSTOMER OR CUSTOMER'S CUSTOMER USES OR PERMITS THE USE OF CIRRUS PRODUCTS IN CRITICAL APPLICATIONS, CUSTOMER AGREES, BY SUCH USE, TO FULLY INDEMNIFY CIRRUS, ITS OFFICERS, DIRECTORS, EMPLOYEES, DISTRIBUTORS AND OTHER AGENTS FROM ANY AND ALL LIABILITY, INCLUDING ATTORNEYS' FEES AND COSTS, THAT MAY RESULT FROM OR ARISE IN CONNECTION WITH THESE USES.

Cirrus Logic, Cirrus, and the Cirrus Logic logo designs, Apex Precision Power, Apex and the Apex Precision Power logo designs are trademarks of Cirrus Logic, Inc. All other brand and product names in this document may be trademarks or service marks of their respective owners.
