

FEATURES

- Sequencing of 3.3 V, 2.5 V, and 1.8 V power supplies
- Red, yellow, and green LEDs indicate power supply status, giving visual demonstration of power-up sequence
- Dedicated power and enable/disable switches
- On-board test points allow examination of ADM1087 and regulator I/O signals
- Sockets allow external through-hole capacitors to be connected manually for customizable time delays

EVALUATION KIT CONTENTS

- ADM1087 evaluation board
- 9 V battery
- 2 100 nF ceramic capacitors
- 4 samples (1 presoldered to on-board adapter)

GENERAL DESCRIPTION

The EVAL-ADM1087EB Evaluation Kit demonstrates how the ADM1087 Simple Sequencer™ can be used to provide time-based sequencing in multiple-supply systems. A pair of ADM1087s are cascaded with three ADP3334 LDO regulators, which supply voltage levels of 3.3 V, 2.5 V, and 1.8 V. In this configuration, the 3.3 V supply switches on as soon as power from a 9 V battery is applied, and the 2.5 V and 1.8 V regulators are enabled by delayed detection signals from the outputs of the previous regulators in the circuit.

Red, yellow, and green LEDs provide a visual indication of the status of each of the three supplies, and two pairs of wire wrap pins allow for experimentation with different capacitor values for different enable time delays. A dedicated enable/disable switch connects directly to the ENIN ADM1087 inputs to demonstrate how a supply can be switched off by driving this pin low with an external logic signal.

EVALUATION BOARD BLOCK DIAGRAM

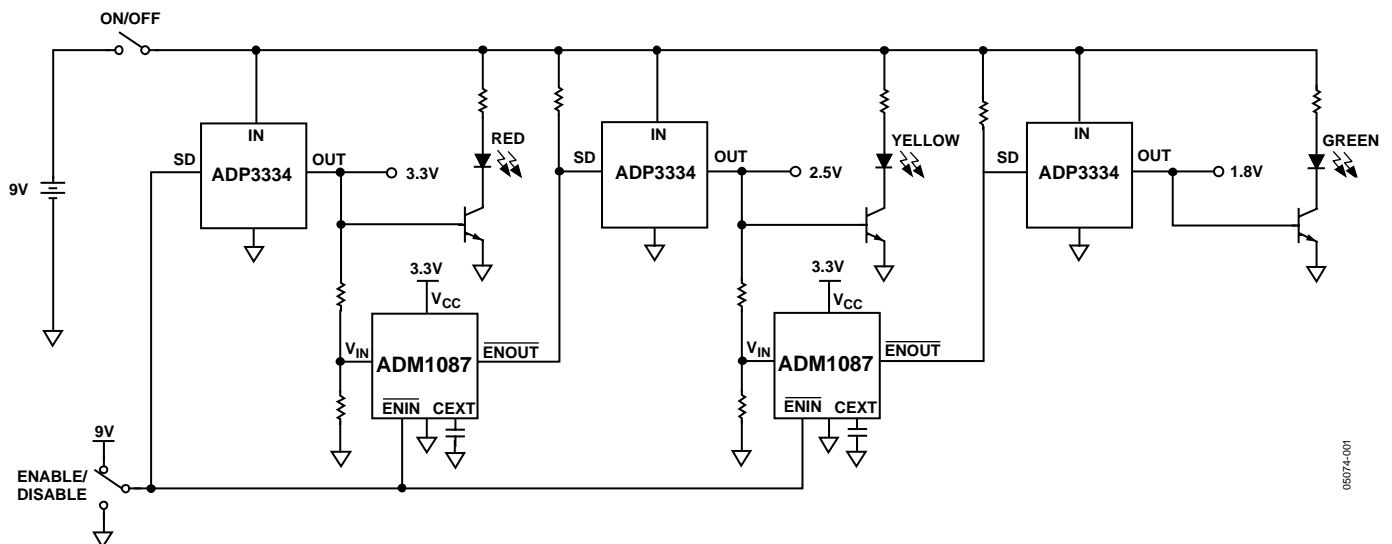

Figure 1.

Rev. 0

Information furnished by Analog Devices is believed to be accurate and reliable. However, no responsibility is assumed by Analog Devices for its use, nor for any infringements of patents or other rights of third parties that may result from its use. Specifications subject to change without notice. No license is granted by implication or otherwise under any patent or patent rights of Analog Devices. Trademarks and registered trademarks are the property of their respective owners.

One Technology Way, P.O. Box 9106, Norwood, MA 02062-9106, U.S.A.
Tel: 781.329.4700 www.analog.com
Fax: 781.326.8703 © 2004 Analog Devices, Inc. All rights reserved.

EVAL-ADM1087EB

TABLE OF CONTENTS

Power-Up/Power-Down Waveforms.....	3	Ordering Information.....	6
EVAL-ADM1087EB Schematic	4	EVAL-ADM1087EB Bill of Materials	6
Evaluation Board Layout Graphics	5	Ordering Guide	7

REVISION HISTORY

9/04—Revision 0: Initial Version

POWER-UP/POWER-DOWN WAVEFORMS

Figure 2 shows the LDO output sequence when battery power is applied and removed. Channel 1 is the 9 V power signal, which is switched on and off via the S1 switch. Channels 2, 3, and 4 are the 3.3 V, 2.5 V, and 1.8 V ADP3334 LDO outputs, respectively. When the 9 V supply is switched on, the 3.3 V, 2.5 V, and 1.8 V supplies power up in sequence, with 4.7 nF external capacitors used to give delays of 22.5 ms between the enabling of the respective LDOs.

The relationship between the size of the external capacitance and the duration of the enable time delay is given by the following formula:

$$t_{EN} = (C \times 4.8 \times 10^6) + 35 \mu\text{s}$$

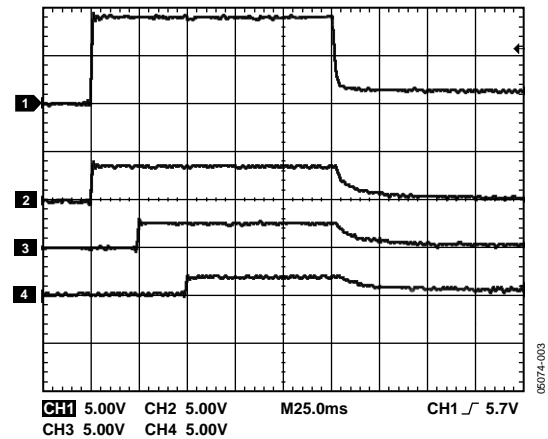

Figure 2. Sequenced Waveforms

EVAL-ADM1087EB

EVAL-ADM1087EB SCHEMATIC

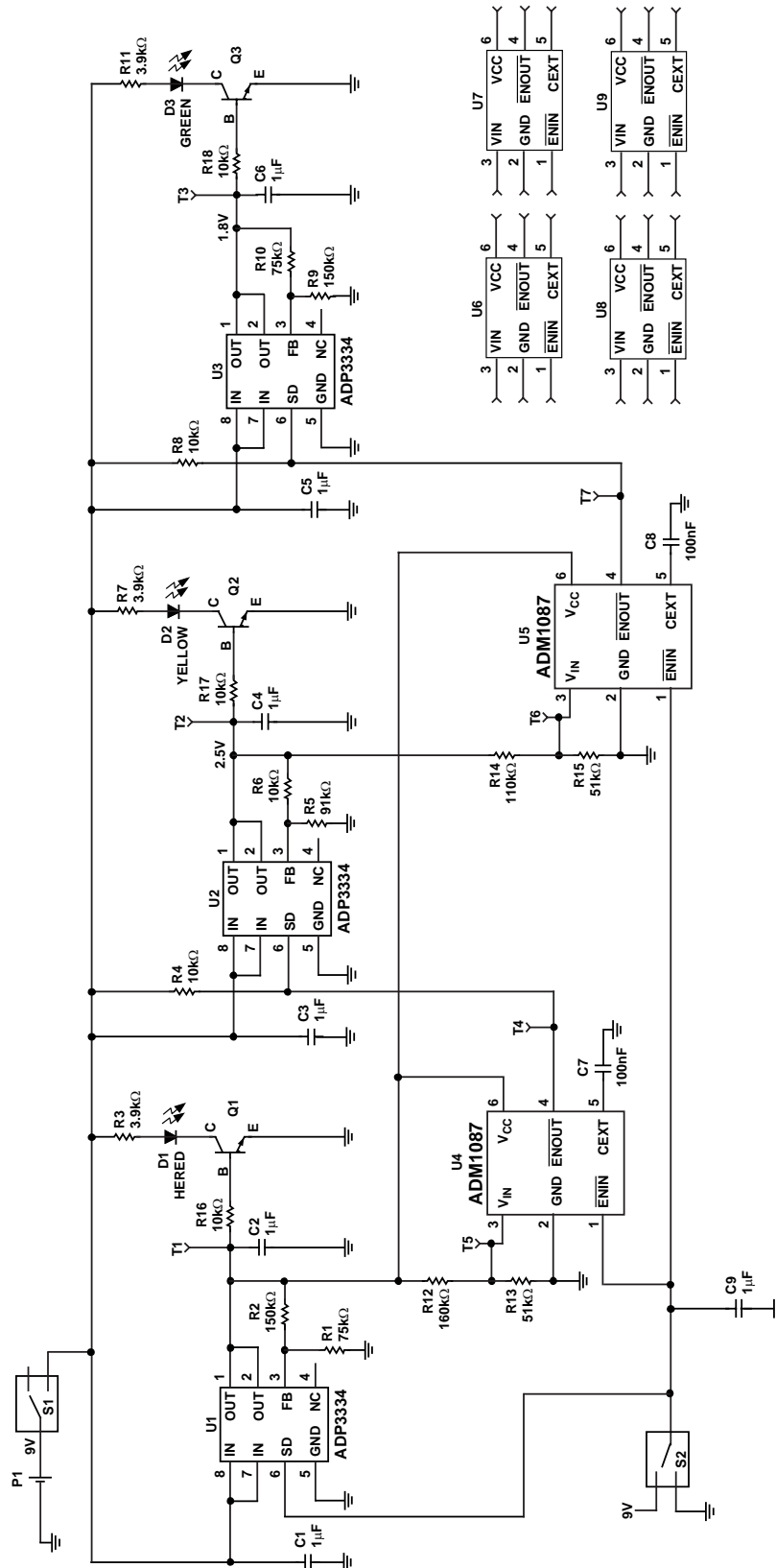

Figure 3.

EVALUATION BOARD LAYOUT GRAPHICS

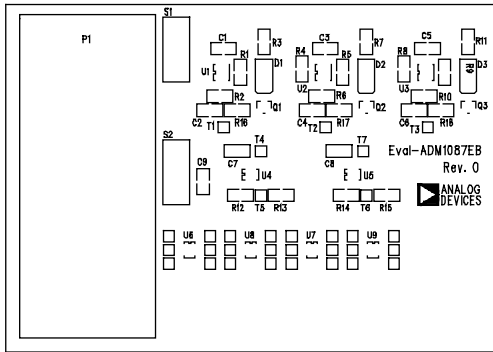

Figure 4. Evaluation Board Layout

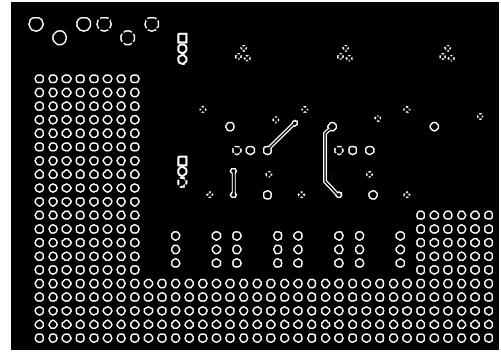

Figure 6. Solder-Side Silkscreen

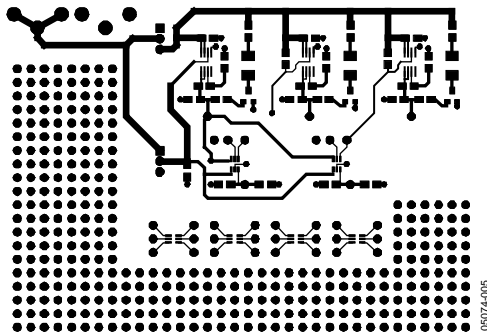

Figure 5. Component-Side Silkscreen

EVAL-ADM1087EB

ORDERING INFORMATION

EVAL-ADM1087EB BILL OF MATERIALS

Table 1.

Name	Part Type	Value	PCB Decal	Part Description	Source	Part Number
C1	CAP	1 μ F	0805	16 V Y5V Ceramic Capacitor	Farnell	FEC 318-8899
C2	CAP	1 μ F	0805	16 V Y5V Ceramic Capacitor	Farnell	FEC 318-8899
C3	CAP	1 μ F	0805	16 V Y5V Ceramic Capacitor	Farnell	FEC 318-8899
C4	CAP	1 μ F	0805	16 V Y5V Ceramic Capacitor	Farnell	FEC 318-8899
C5	CAP	1 μ F	0805	16 V Y5V Ceramic Capacitor	Farnell	FEC 318-8899
C6	CAP	1 μ F	0805	16 V Y5V Ceramic Capacitor	Farnell	FEC 318-8899
C7	Wire Wrap Pins		CAPVMR04	Wire Wrap Pins \times 2		
C8	Wire Wrap Pins		CAPVMR04	Wire Wrap Pins \times 2		
C9	CAP	1 μ F	0805	16 V Y5V Ceramic Capacitor	Farnell	FEC 318-8899
D1	LED		LED_SMT	HE Red LED	Farnell	FEC 515-607
D2	LED		LED_SMT	Yellow LED	Farnell	FEC 515-619
D3	LED		LED_SMT	Green LED	Farnell	FEC 515-620
P1	BATT_PP3		BATT_PP3	Pair Battery Connectors	Farnell	FEC 723-988
Q1	BC850B		SOT23	npn BJT	Farnell	FEC 305-0506
Q2	BC850B		SOT23	npn BJT	Farnell	FEC 305-0506
Q3	BC850B		SOT23	npn BJT	Farnell	FEC 305-0506
R1	RES	75 k Ω	0805	0.1 W Resistor	Farnell	FEC 321-8284
R2	RES	150 k Ω	0805	0.1 W Resistor	Farnell	FEC 912-116
R3	RES	3.9 k Ω	0805	0.1 W Resistor	Farnell	FEC 911-926
R4	RES	10 k Ω	0805	0.1 W Resistor	Farnell	FEC 911-975
R5	RES	91 k Ω	0805	0.1 W Resistor	Farnell	FEC 32108296
R6	RES	110 k Ω	0805	0.1 W Resistor	Farnell	FEC 321-8302
R7	RES	3.9 k Ω	0805	0.1 W Resistor	Farnell	FEC 911-926
R8	RES	10k Ω	0805	0.1 W Resistor	Farnell	FEC 911-975
R9	RES	150 k Ω	0805	0.1 W Resistor	Farnell	FEC 912-116
R10	RES	75 k Ω	0805	0.1 W Resistor	Farnell	FEC 321-8284
R11	RES	3.9 k Ω	0805	0.1 W Resistor	Farnell	FEC 911-926
R12	RES	160 k Ω	0805	0.1 W Resistor	Farnell	FEC 321-8326
R13	RES	51 k Ω	0805	0.1 W Resistor	Farnell	FEC 321-8260
R14	RES	110 k Ω	0805	0.1 W Resistor	Farnell	FEC 321-8302
R15	RES	51 k Ω	0805	0.1 W Resistor	Farnell	FEC 321-8260
R16	RES	10 k Ω	0805	0.1 W Resistor	Farnell	FEC 911-975
R17	RES	10 k Ω	0805	0.1 W Resistor	Farnell	FEC 911-975
R18	RES	10 k Ω	0805	0.1 W Resistor	Farnell	FEC 911-975
S1	SW-SPDT-SLIDE		SW-SPDT-SLIDE	SPDT Slide Switch	Farnell	FEC 733-647
S2	SW-SPDT-SLIDE		SW-SPDT-SLIDE	SPDT Slide Switch	Farnell	FEC 733-647
T1	TESTPOINT		TESTPOINT	Testpoint	Farnell	FEC 200-207
T2	TESTPOINT		TESTPOINT	Testpoint	Farnell	FEC 200-207
T3	TESTPOINT		TESTPOINT	Testpoint	Farnell	FEC 200-207
T4	TESTPOINT		TESTPOINT	Testpoint	Farnell	FEC 200-207
T5	TESTPOINT		TESTPOINT	Testpoint	Farnell	FEC 200-207
T6	TESTPOINT		TESTPOINT	Testpoint	Farnell	FEC 200-207
T7	TESTPOINT		TESTPOINT	Testpoint	Farnell	FEC 200-207
U1	ADP3334		MSO8	LDO Regulator	Analog Devices	ADP3334ARM
U2	ADP3334		MSO8	LDO Regulator	Analog Devices	ADP3334ARM
U3	ADP3334		MSO8	LDO Regulator	Analog Devices	ADP3334ARM
U4	ADM1087		SC70-6	Simple Sequencer	Analog Devices	ADM1087AKS

EVAL-ADM1087EB

Name	Part Type	Value	PCB Decal	Part Description	Source	Part Number
U5	ADM1087		SC70-6	Simple Sequencer	Analog Devices	ADM1087AKS
U6	ADM1085-TEMP		SC70-6	Simple Sequencer	Analog Devices	ADM1085AKS
U7	ADM1086-TEMP		SC70-6	Simple Sequencer	Analog Devices	ADM1086AKS
U8	ADM1087-TEMP		SC70-6	Simple Sequencer	Analog Devices	ADM1087AKS
U9	ADM1088-TEMP Feet		SC70-6	Simple Sequencer Rubber Stick-On Feet	Analog Devices 3M	ADM1088AKS FEC 148-922

ORDERING GUIDE

Model	Package Description
EVAL-ADM1087EB	Evaluation Board for ADM1087 Simple Sequencer

ESD CAUTION

ESD (electrostatic discharge) sensitive device. Electrostatic charges as high as 4000 V readily accumulate on the human body and test equipment and can discharge without detection. Although this product features proprietary ESD protection circuitry, permanent damage may occur on devices subjected to high energy electrostatic discharges. Therefore, proper ESD precautions are recommended to avoid performance degradation or loss of functionality.



EVAL-ADM1087EB

NOTES