

Totally Logical

Z8937100ZAC

Z89371 ACCESSORY KIT

GENERAL DESCRIPTION

The Z89371 Accessory Kit is specifically designed to enable the Z8932101ZEM or Z8932102ZEM Emulator to program the Z89371 OTPs (the adapters are included with the Z8932102ZEM).

SUPPORTED DEVICES

Packages	OTP Programming
44-pin PLCC	Z89371
44-pin QFP	Z89371

SPECIFICATIONS

Operating Temperature

20°C, ±10°C

Operating Humidity

10%–90% RH (noncondensing)

PACKAGE CONTENTS

Hardware

Z89371 PLCC Programming Adapter (99C0599-001)

Z89371 QFP Programming Adapter (99C0386-001)

Documentation

Data Sheet

Additional Items Required (Not Supplied)

Z8932101ZEM or Z8932102ZEM Emulator as OTP Programmer

DSP ICE GUI Software, version C3.12A or later

PROGRAMMING ADAPTER INSTALLATION PROCEDURE

1. Ensure that all the necessary hardware and software is properly installed.
2. Plug the appropriate Programming Adapter into the 40-pin DIP socket of the ZEM emulator. Carefully align pin 1 of the adapter to pin 1 of the 40-pin socket.
3. Power up the system.
4. Start the DSP GUI application.
5. Open either the DSP Code Memory window or the Debug window.
6. Select the File menu to download the object code to be programmed.
7. Select the OTP menu item.
8. Make sure the device label faces up. Plug a Z89371 OTP device into the 44-pin ZIF socket of the programming adapter. Carefully align pin 1 of the OTP with the silk screen marker of pin 1 on the programming adapter board. Insert the OTP device gently, and let it sit tight and flat inside the ZIF socket. For QFP devices, close the lid of the socket.
9. Begin programming by clicking the Program button on the DSP GUI.
10. After successful programming, remove the device by pushing the socket down and popping the OTP device out of the socket.

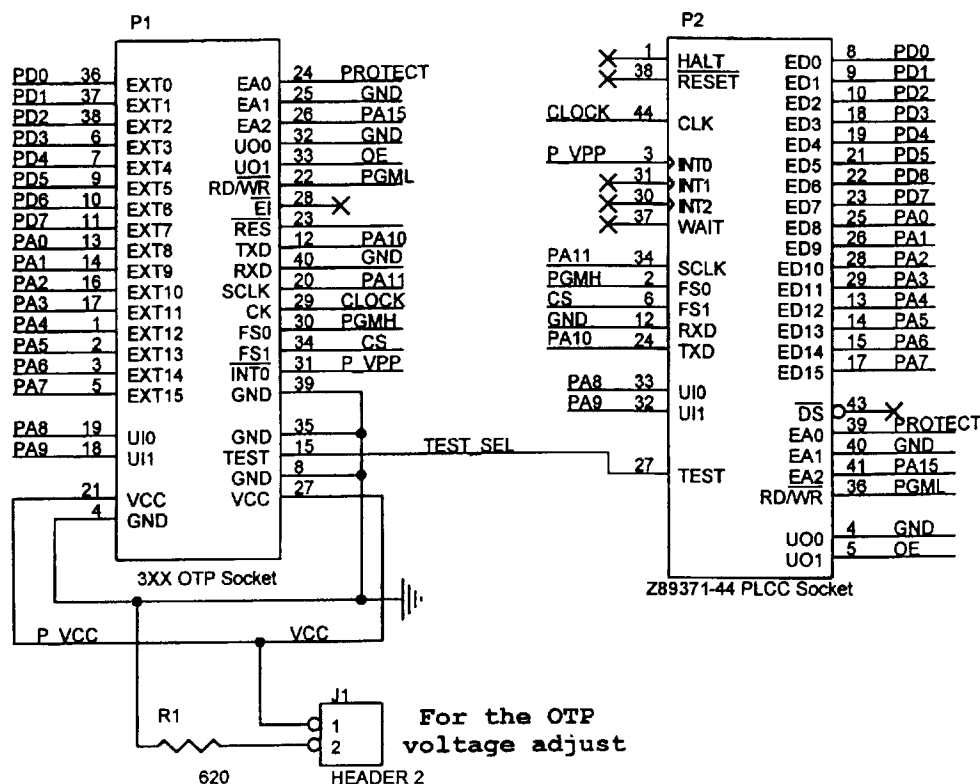

Figure 1. Schematic for Z89371 PLCC Programming Adapter

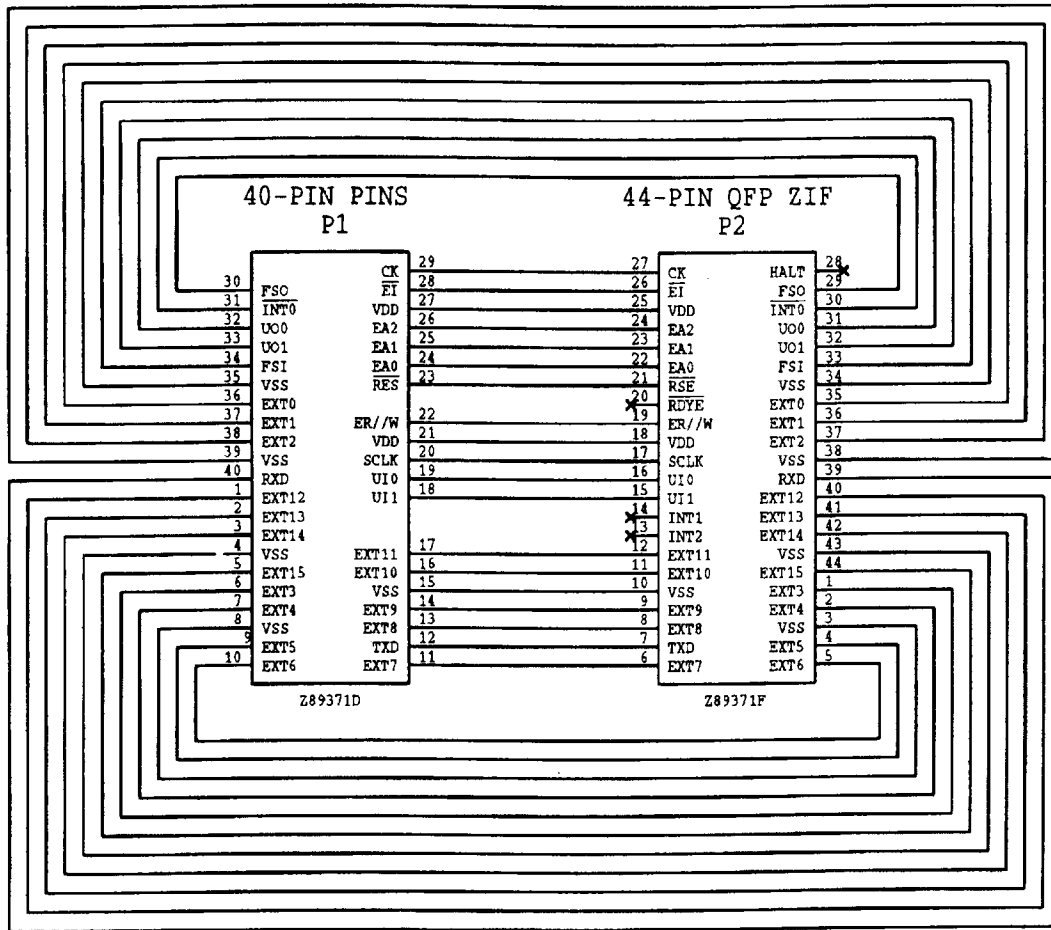

Figure 2. Schematic for Z89371 QFP Programming Adapter

© 1998 by ZiLOG, Inc. All rights reserved. No part of this document may be copied or reproduced in any form or by any means without the prior written consent of ZiLOG, Inc. The information in this document is subject to change without notice. Devices sold by ZiLOG, Inc. are covered by warranty and patent indemnification provisions appearing in ZiLOG, Inc. Terms and Conditions of Sale only.

ZILOG, INC. MAKES NO WARRANTY, EXPRESS, STATUTORY, IMPLIED OR BY DESCRIPTION, REGARDING THE INFORMATION SET FORTH HEREIN OR REGARDING THE FREEDOM OF THE DESCRIBED DEVICES FROM INTELLECTUAL PROPERTY INFRINGEMENT. ZILOG, INC. MAKES NO WARRANTY OF MERCHANTABILITY OR FITNESS FOR ANY PURPOSE.

ZiLOG, Inc. shall not be responsible for any errors that may appear in this document. ZiLOG, Inc. makes no commitment to

update or keep current the information contained in this document.

ZiLOG's products are not authorized for use as critical components in life support devices or systems unless a specific written agreement pertaining to such intended use is executed between the customer and ZiLOG prior to use. Life support devices or systems are those which are intended for surgical implantation into the body, or which sustains life whose failure to perform, when properly used in accordance with instructions for use provided in the labeling, can be reasonably expected to result in significant injury to the user.

ZiLOG, Inc.
910 East Hamilton Avenue, Suite 110
Campbell, CA 95008
Telephone (408) 558-8500
FAX 408 558-8300
Internet: <http://www.zilog.com>
