

Automatic Calibration Circuitry

OCB 100 Series



Features

- Automatic Calibration Circuitry for Optoelectronic Devices
- Calibration point 50% of Vcc
- Logic Trip Points either 1/3 and 2/3 Vcc
- Can be used with Reflective or Interruptive Devices
- Vcc 4.5 V to 5.5 Volts
- Logic and Analog Outputs

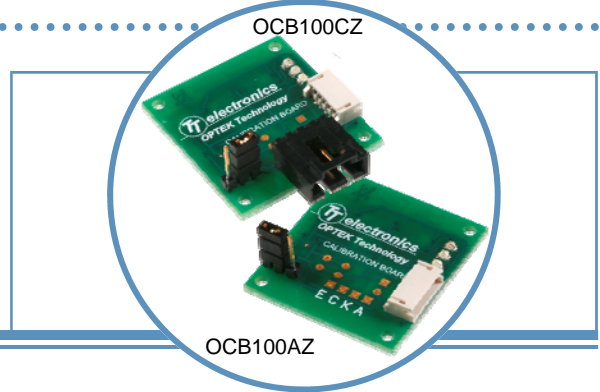

The **OCB100** series OPTEK Circuit Boards are configured to optimize the design effort needed to use a reflective or interruptive device. The **OCB100** series are easy to use requiring only an optical device and power supply. Four lights are provided on the board that acknowledge when the device is calibrated (**Green** LED), that the device could not be calibrated (**Red** LED) and when the analog output has reached the logical trip higher than the calibration point (**Blue** LED) or lower than the calibration point (**Green** LED). The internal phototransistor load resistance can be set for three different values (~2.5K, ~9.6K or ~27K Ohms). A Reset/Clear pin is provided for remote signaling to calibrate of the system.

The **OCB100AZ** comes with a PCBoard, interface cable OCB100-MC24 and all electronics ready for an optical device with a 0.320" [8.13 mm] X 0.100" [2.54 mm] spacing between the leads.

The **OCB100CZ** comes with a PCBoard, interface cable OCB100-MC24 and a Molex (70553-0038) connector to interface with a remote device. (See OCBKIT-100 for examples).

See "Theory of Operation" for detailed information.

For a custom PCBoard design for your unique situation, contact your OPTEK representative.

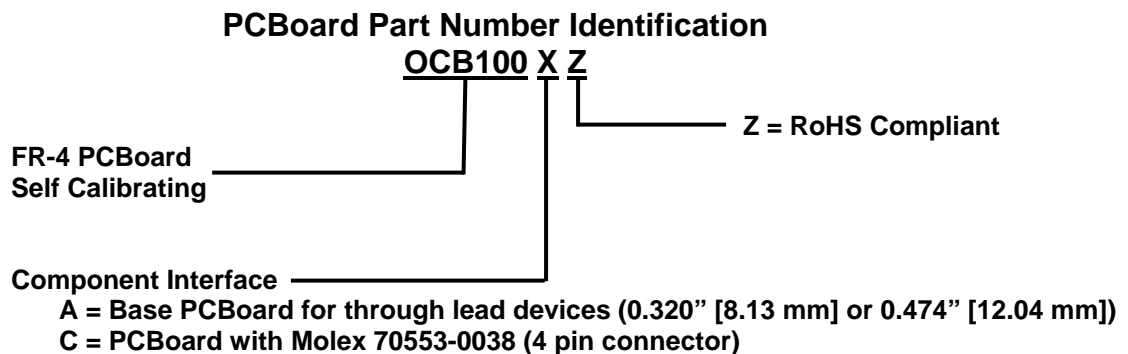

RoHS

Comes with OCB100-MC24 interface cable.

OPTEK reserves the right to make changes at any time in order to improve design and to supply the best product possible.

Automatic Calibration Circuitry

OCB 100 Series



Theory of operation:

The OCB100 series is designed to minimize the change of optical devices due to manufacturing variance. This system can be used to calibrate either reflective or interruptive devices and provide a consistent output eliminating the requirement to confirm either the LED drive resistance or Phototransistor Load Resistor to provide a consistent output steady state condition. With the OCB100, the design engineer can narrow the expected startup output state providing a device that will operate the same for years with the same startup state thus enhancing the reliability and consistence of the system. Degradation of the LED or phototransistor is compensated for each time the system is calibrated allowing the system to provide a known, consistent output level resulting in years of consistent quality. The OCB100 series are designed to maintain the calibrated setting even if power is lost. This allows faster startup without the need for calibration every time the device is initiated. The designer can initiate the calibration procedure at any time by momentarily grounding J1-Pin-4 (green wire). This allows the device to be remotely calibrated then mounted in the equipment.

The PCBoard has a set of shorting pins allowing the user to change the phototransistor load resistor. By arranging the shorting bar to the appropriate location (see table), the load resistance can be changed from approximately 2.5K to 27 K Ω . Increasing the load resistor increases the sensitivity of the device.

When the "Calibrate" pin (#4) is momentarily grounded, the system begins its calibration process and raises the current through the LED, from 0 mA to 14 mA, until the phototransistor reaches the preset calibration point. A green calibration light will blink 3 times when the preset phototransistor output level is reached. At this time, the LED drive current is locked and maintained until Reset/Clear pin is grounded. If for some reason, the LED drive current reaches the maximum allowable value, a RED warning light will be turned on. During the calibration process, remote monitoring of J1-Pin3 allows the designer to ensure the system is calibrated (this output should be at the preset calibrated output level when the calibration procedure is completed). Adjusting the phototransistor load resistor may allow the system to calibrate properly.

After the calibration process is complete, the device is ready for acknowledgement of a change in the signal. The design engineer can monitor either the Analog Output (J1-Pin 5) or Logical Output (J1-Pin 2 or J1-Pin 3).

The Analog Output allows the design engineer to set any reference point to recognize an optical change for the device being monitored. The Analog Output can be used with reflective devices to monitor small changes in the distance from the device. The further the target is away from the device, the lower the reflected signal.

The Logical output will change state once the preset optical light condition is reached. The "Logic Out A" switches when the optical signal increases above approximately 2/3 of V_{CC} while "Logic Out B" switches when the optical signal decreases below approximately 1/3 of V_{CC} .

As with all optical devices, the switching condition is consistent with the phototransistor receiving a preset light level. This switching position and light level may vary dependent on several possible factors such as:

- Ambient light variation ((reduced or eliminated with periodic recalibration)
- LED and phototransistor pair degradation (eliminated with periodic recalibration)
- Contamination in front of either the LED or phototransistor (reduced or eliminated with periodic cleaning)
- System power variation (reduced or eliminated with periodic recalibration)
- Temperature changes (reduced or eliminated with periodic recalibration)

The OCB100 PCBoard can be wired directly to any Optical device with an LED and Phototransistor.

- Interruptive devices / slotted switches / interruptive encoders
- Reflective devices / reflective switches / reflective encoders
- Specialty devices / fluid sensors
- Etc.

OPTEK reserves the right to make changes at any time in order to improve design and to supply the best product possible.

Automatic Calibration Circuitry

OCB 100 Series

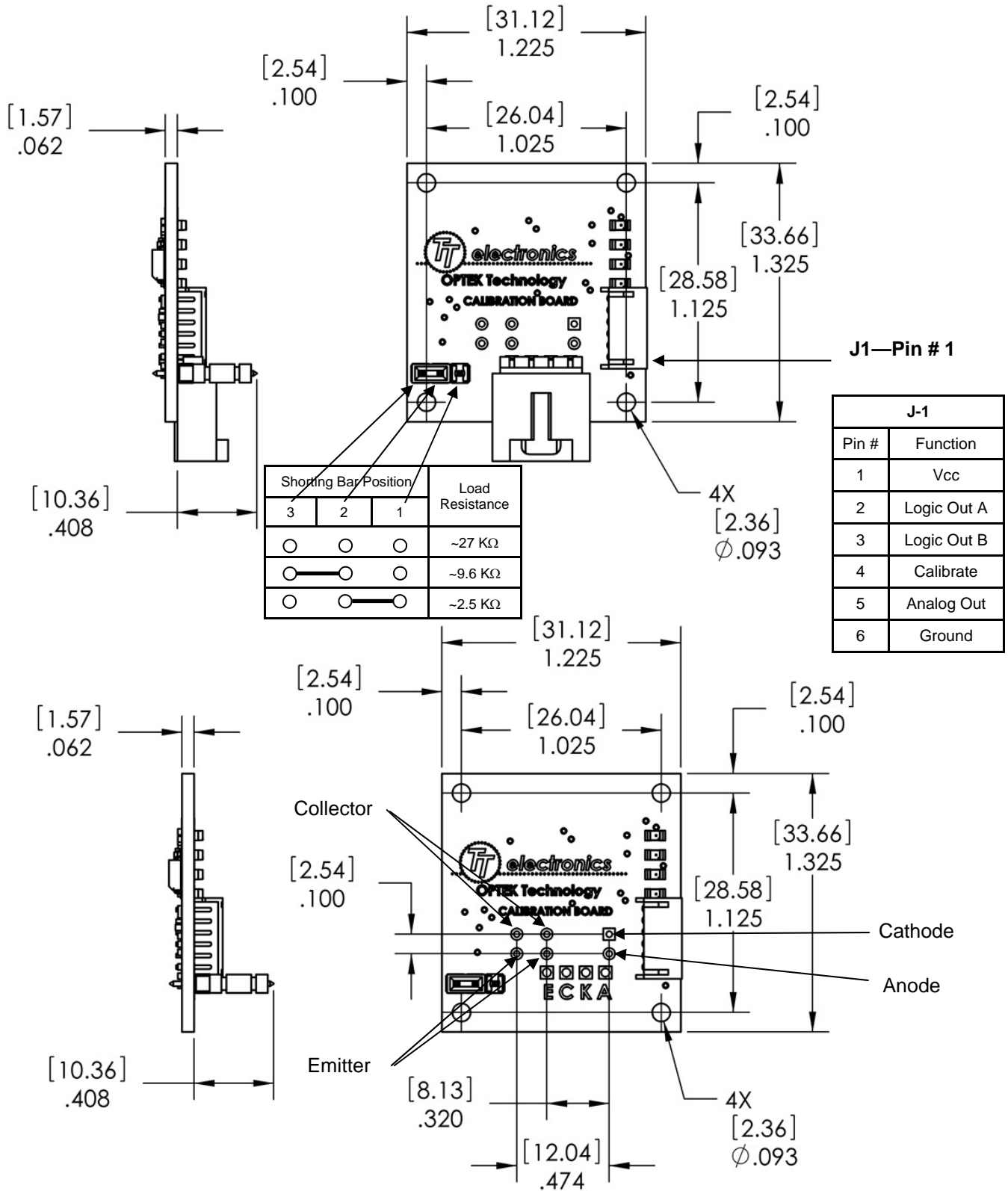

OPTEK reserves the right to make changes at any time in order to improve design and to supply the best product possible.

Automatic Calibration Circuitry

OCB 100 Series



Absolute Maximum Ratings (T_A=25°C unless otherwise noted)

Storage & Operating Temperature Range	-40°C to +85°C
Lead Soldering Temperature [1/16 inch (1.6mm) from the case for 5 sec. with soldering iron]	260°C

Electrical Characteristics (T_A = 25°C unless otherwise noted)

Symbol	Parameter	Min	Max	Units	Conditions
V _{CC}	Supply Voltage	4.5	5.5	V	
I _{CC}	Supply Current	-	35	mA	V _{CC} = 5.0 Volts
V _{OL}	Low Level Output Voltage	-	1.2	V	V _{CC} = 5.0 Volts, V _{OUT} < 2.2 Volts
V _{OH}	High Level Output Voltage	3.5	-	V	V _{CC} = 5.0 Volts, V _{OUT} > 2.8 Volts

Schematic for OCB100 PCBoard

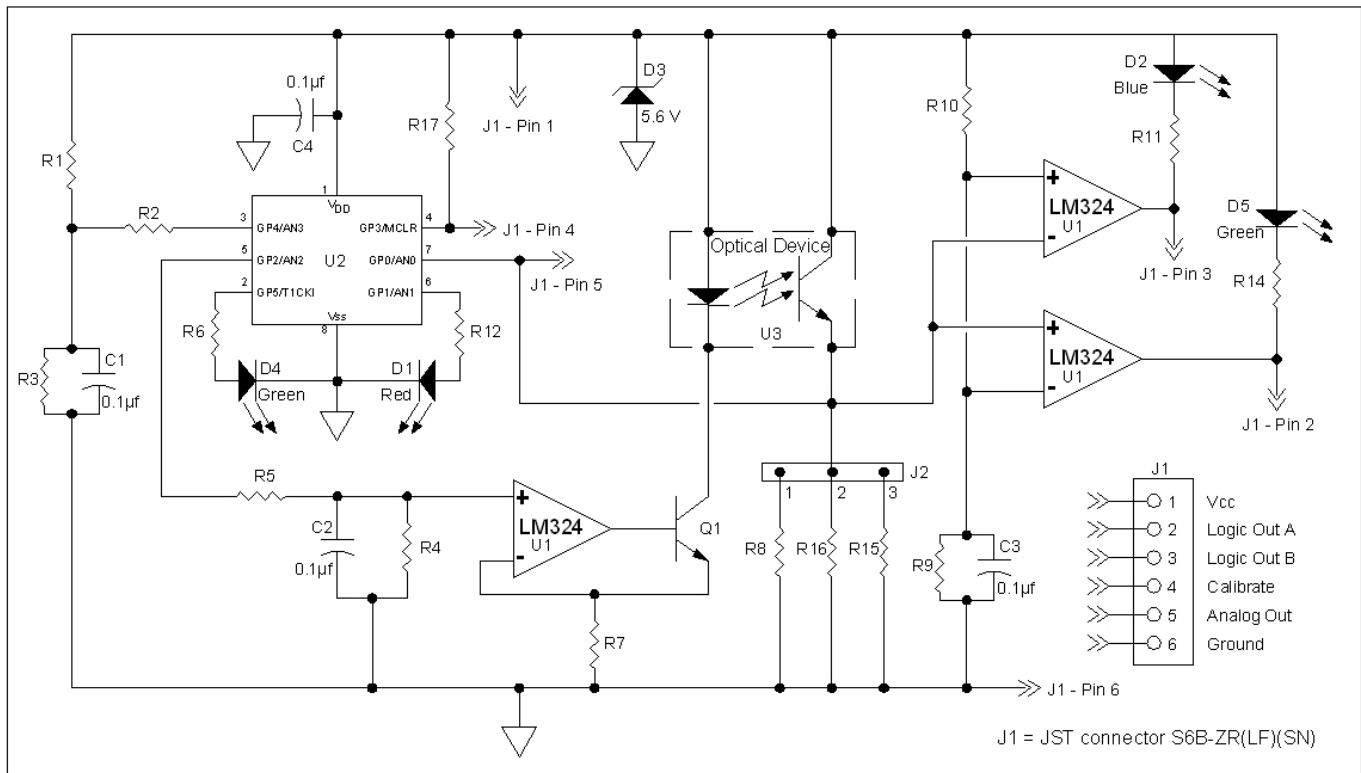

OCB100-MC24

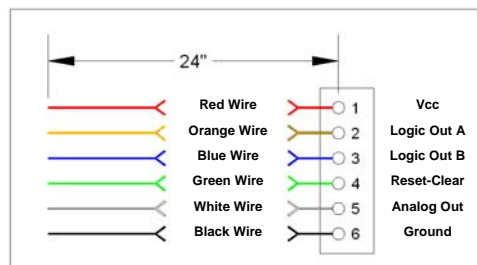

OPTEK reserves the right to make changes at any time in order to improve design and to supply the best product possible.