



MAXSPCSPARTAN6+ Evaluation Kit

General Description

The MAXSPCSPARTAN6+ evaluation kit (EV kit) is designed to facilitate the use of Maxim ADCs and DACs with any evaluation board made for Xilinx® Spartan® 6 series FPGAs. The EV kit contains the MAX11612 and MAX11040 ADCs and two cascaded MAX5135 DACs. The MAX11612 is a very-low-power, 4-channel, 2-wire, 12-bit, SAR ADC. This ADC operates with a 5V supply and has an internal reference of 4.096V.

The MAX11040 is an SPI™-compatible, 4-channel, simultaneous-sampling, cascadable, 24-bit, sigma-delta ADC. The MAX5135 is the industry's smallest, 12-bit, voltage-output DAC.

Features

- ◆ 12-Bit, 2-/4-Channel, SAR ADC Support (MAX11612)
- ◆ 24-Bit, 4-Channel, Programmable Data Rate, Sigma-Delta ADC Support (MAX11040)
- ◆ 12-Bit, 4-Channel DAC Support (MAX5135)
- ◆ Connects with any Spartan 6 Evaluation Boards Through a Standard FMC VITA-57.1 LPC Connector

Ordering Information

PART	TYPE
MAXSPCSPARTAN6+	EV Kit

+Denotes lead(Pb)-free and RoHS compliant.

Component List

DESIGNATION	QTY	DESCRIPTION
C1	1	10μF ±20%, 25V ceramic capacitor (1206)
C2, C3, C11–C14, C21–C26, C29–C32	16	0.1μF ±10%, 50V ceramic capacitors (0603)
C4, C15–C20, C27, C28	9	1μF ±10%, 25V ceramic capacitors (0603)
C5, C6	2	18pF ±5%, 50V C0G ceramic capacitors (0603)
C7–C10	4	0.01μF ±5%, 25V ceramic capacitors (0603)
C33, C34	2	47pF, 50V ceramic capacitors (0603)
C35, C36	2	4.7μF ±10%, 10V ceramic capacitors (0603)
D1, D2	2	Orange SMT LEDs (0603)
D3, D4, D5	3	Green SMT LEDs (0603)
J1	1	FMC LPC connector (VITA-57.1)
J2	1	8 x 2-pin R/A header (2.54mm)
J3, J4	2	8 x 2-pin headers (2.54mm)
J5	1	8-pin inline receptacle, 0.1in centers
J6, J7	2	3-pin headers (2.54mm)

DESIGNATION	QTY	DESCRIPTION
L1	1	10μH ±5% inductor (0603, 0)
R1, R2, R16, R17	4	2.2kΩ ±5% resistors (0603)
R3–R10	8	49.9Ω ±0.1% resistors (0603)
R11–R14	4	100Ω ±1% resistors (0603)
R15, R21–R24	5	4.7kΩ ±0.1% resistors (0603)
R18, R19, R20	3	0Ω ±1% resistors (0603)
U1	1	Step-down converter (6 SOT23) Maxim MAX1837EUT50#G16
U2	1	Low-power ADC (8 μMAX®) Maxim MAX11612EUA+
U3	1	Sigma-delta ADC (38 TSSOP) Maxim MAX11040GUU+
U4	1	Bidirectional level translator (12 TQFN-EP*) Maxim MAX3395EETC+
U5	1	8-channel level translator (20 TSSOP) Maxim MAX3002EUP
U6, U7	2	Quad 12-bit DACs (24 TQFN-EP*) Maxim MAX5135GTG+
Y1	1	24.576MHz, 18pF crystal
—	1	PCB: MAXSPCSPARTAN6+

*EP = Exposed pad.

Xilinx and Spartan are registered trademarks of Xilinx.
SPI is a trademark of Motorola, Inc.
μMAX is a registered trademark of Maxim Integrated Products, Inc.



Maxim Integrated Products 1

For pricing, delivery, and ordering information, please contact Maxim Direct at 1-888-629-4642, or visit Maxim's website at www.maxim-ic.com.

Evaluates: MAX5135/MAX11040/MAX11612

MAXSPCSPARTAN6+ Evaluation Kit

Quick Start

The MAXSPCSPARTAN6+ board can be plugged in to any Spartan 6 series FPGA evaluation board. A two-step configuration is needed to use this card with the FPGA evaluation board:

- 1) Place a shunt on pins 2-3 of header J7 (i.e., +3V3FMC to +3V3).
- 2) Place a shunt on pins 2-3 of header J6 (i.e., +5VREG to +5V).

Now connect the MAXSPCSPARTAN6+ board to the FPGA EV kit. On power-up, LEDs D3, D4, and D5 should glow, indicating a power-up state.

Detailed Description of Hardware

The MAXSPCSPARTAN6+ board is loaded with Maxim's ADCs and DACs and makes it very easy to integrate the FPGA with any analog interface.

Communication with the MAX11612

The MAX11612 is a 12-bit, 2-/4-channel, I²C-compatible ADC. The FPGA can drive commands for data acquisition from the MAX11612 on the I²C slave address 0110100. The MAX11612 can work with the internal reference of 4.096V or the external reference connected at the AD3 port of J2. If internal reference is used; all 4 channels can be sampled from AD0–AD3. For more information, refer to the MAX11612 IC data sheet.

Communication with the MAX11040

The MAX11040 is a 24-bit, 4-channel, SPI-compatible, sigma-delta ADC with programmable output data rate. It has an internal reference of 2.5V with ± 2.2 V input range. Input ports are marked as AD0-/AD0+ to AD3-/AD3+ on J3. External reference can also be applied. The MAX11040 does simultaneous sampling and data for all 4 channels and can be acquired in one read.

This ADC has four standard connections for SPI communication. It also has an extra signal (DRDYOUT) that interrupts the FPGA at every end-of-conversion to sample the data. For more information, refer to the MAX11040 IC data sheet.

Communication with the MAX5135

The MAX5135 is a 12-bit, 4-channel, voltage output, SPI-compatible DAC. The MAXSPCSPARTAN6+ board contains two MAX5135 ICs in a cascaded configuration. The DAC channels are marked as DA0–DA3 on J2 and DA4–DA7 on J3. For more information, refer to the MAX5135 IC data sheet.

Table 1. MAXSPCSPARTAN6+ Connector J2 Description

J2 PIN NO.	LABEL	FUNCTION
1	+5V	+5V, 250mA supply for external circuit
2	N.C.	Not connected
3	GND	Ground
4	DA0	DAC output from channel 0 of U6 (MAX5135)
5	GND	Ground
6	DA1	DAC output from channel 1 of U6 (MAX5135)
7	GND	Ground
8	DA2	DAC output from channel 2 of U6 (MAX5135)
9	GND	Ground
10	DA3	DAC output from channel 3 of U6 (MAX5135)
11	AD1	ADC input to channel 1 of U2 (MAX11612)
12	AD0	ADC input to channel 0 of U2 (MAX11612)
13	GND	Ground
14	I/O	Digital input/output connected to FMC connector at C18
15	AD3	ADC input to channel 3 of U2 (MAX11612)
16	AD2	ADC input to channel 2 of U2 (MAX11612)

MAXSPCSPARTAN6+ Evaluation Kit

Table 2. MAXSPCSPARTAN6+ Connector J3 Description

J3 PIN NO.	LABEL	FUNCTION
1	+5V	+5V, 250mA supply for external circuit
2	N.C.	Not connected
3	AD3-	ADC negative input to channel 3 of U3 (MAX11040)
4	AD3+	ADC positive input to channel 3 of U3 (MAX11040)
5	AD2-	ADC negative input to channel 2 of U3 (MAX11040)
6	AD2+	ADC positive input to channel 2 of U3 (MAX11040)
7	AD1-	ADC negative input to channel 1 of U3 (MAX11040)
8	AD1+	ADC positive input to channel 1 of U3 (MAX11040)
9	AD0-	ADC negative input to channel 0 of U3 (MAX11040)
10	AD0+	ADC positive input to channel 0 of U3 (MAX11040)
11	DA5	DAC output from channel 1 of U7 (MAX5135)
12	DA4	DAC output from channel 0 of U7 (MAX5135)
13	GND	Ground
14	N.C.	Not connected
15	DA7	DAC output from channel 2 of U7 (MAX5135)
16	DA6	DAC output from channel 2 of U7 (MAX5135)

Table 3. MAXSPCSPARTAN6+ Connector J4 Description

J4 PIN NO.	LABEL	FUNCTION
1	GND	Ground
2	N.C.	Not connected
3	DRDY	DRDYOUT of MAX11040 going to the FMC connector at C26*
4	N.C.	Not connected
5	GPIO	Digital I/O going to the FMC connector at C18 from J2*
6	N.C.	Not connected
7	MOSI	SPI: MOSI connected to the FMC connector at C14 from the DAC (MAX5135) and ADC (MAX11040)*
8	N.C.	Not connected
9	CS_AD	ADC (MAX11040) CS connected to the FMC connector at C11*
10	CS_DAC	DAC (MAX5135) CS connected to the FMC connector at C22*
11	SCLK	SPI: SCLK connected to the FMC connector at C10 and going to the DAC (MAX5135) and ADC (MAX1100)*
12	N.C.	Not connected
13	MISO	SPI: MISO connected to the FMC connector at C15 and going to the DAC (MAX5135) and ADC (MAX1100)*
14	SCL	I ² C: SCL connected to the FMC connector at C30 and going to the ADC (MAX11612)*
15	+3V3USB	Not connected
16	SDA	I ² C: SDA connected to the FMC connector at C31 and going to the ADC (MAX11612)*

*Connected with J4 for probing only.

Evaluates: MAX5135/MAX11040/MAX11612

Evaluates: MAX5135/MAX11040/MAX11612

MAXSPCSPARTAN6+ Evaluation Kit

MAX3002

+1.2V to +5.5V, 15kV ESD-Protected, 0.1A, 35Mbps, 8-Channel Level Translators

**Bidirectional Level Translation Without Direction
20Mbps Guaranteed Data Rate Options**

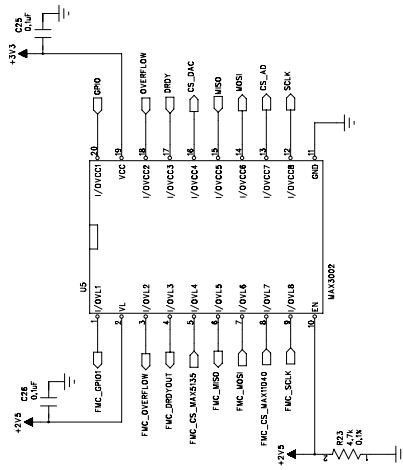

MAX3395

15kV ESD-Protected, High-Drive Current, Dual-/Quad-/Octal-Level Translators with Speed-Up Circuitry

Bidirectional Level Translation Without Direction

6Mbps Push-Pull/1Mbps Open-Drain Guaranteed

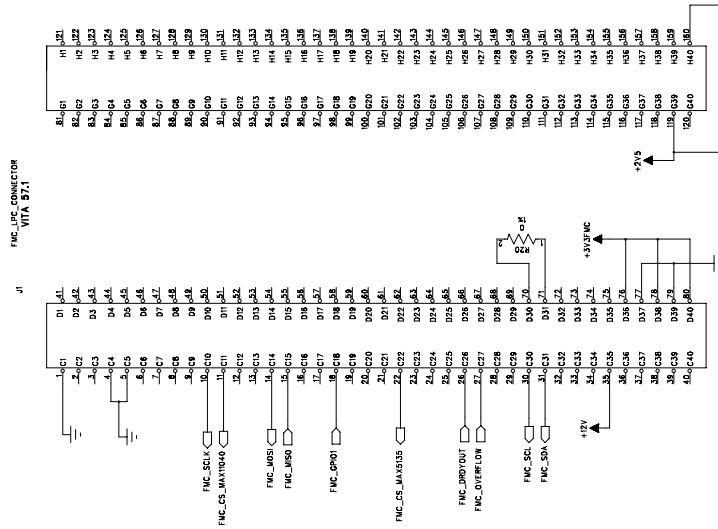
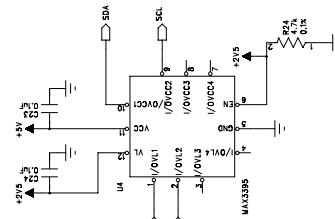

Figure 1a. MAXSPCSPARTAN6+ EV Kit Schematic (Sheet 1 of 4)

MAXSPCSPARTAN6+ Evaluation Kit

Evaluates: MAX5135/MAX11040/MAX11612

MAX11040

24-Bit, 4-Channel, Simultaneous-Sampling, Cascadable, Sigma-Delta ADC

2.2V Full-Scale Input Range

SPI-/QSPI-/MICROWIRE-/DSP-Compatible
4-Wire Serial Interface

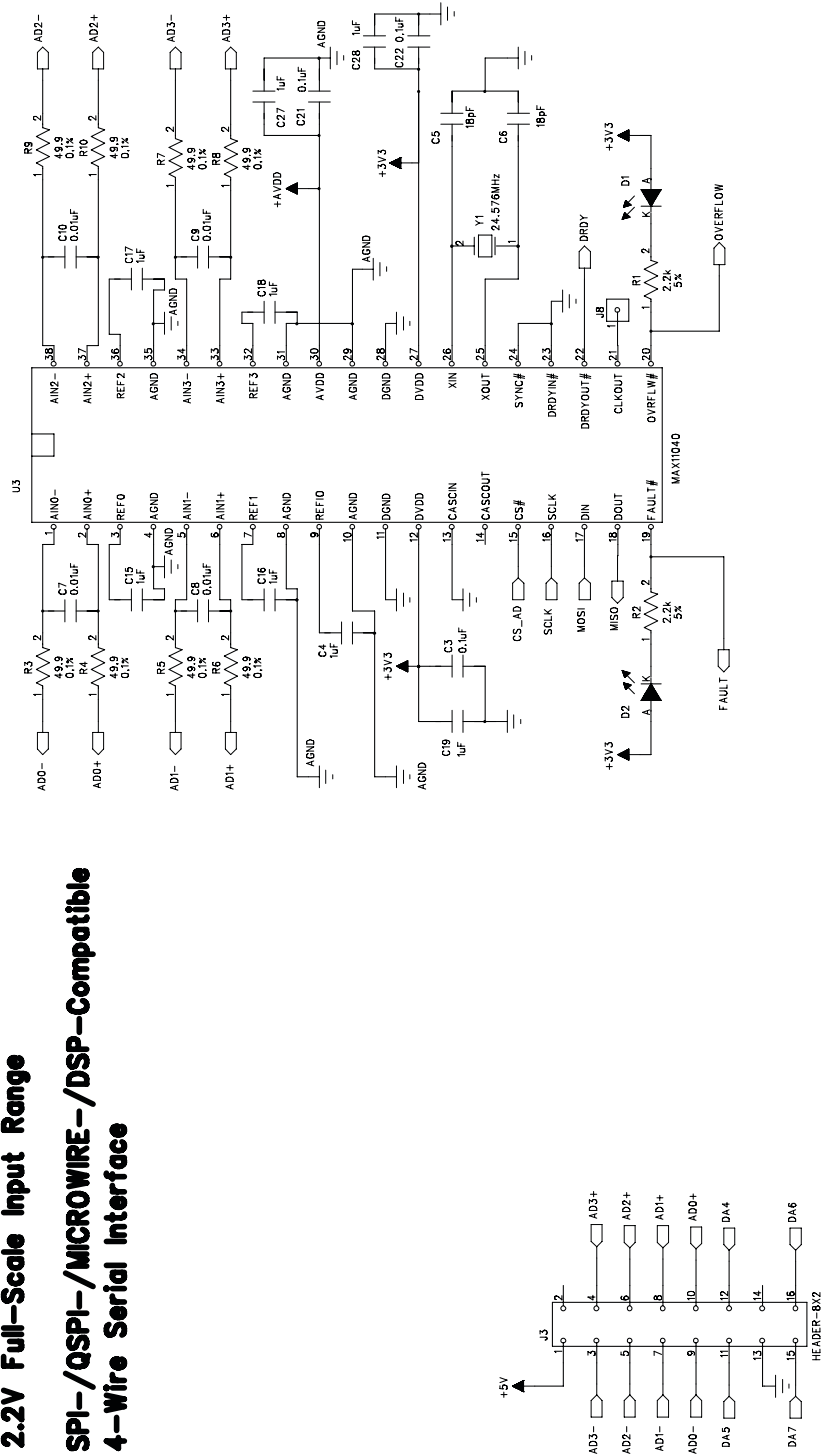

Figure 1b. MAXSPCSPARTAN6+ EV Kit Schematic (Sheet 2 of 4)

MAXSPCSPARTAN6+ Evaluation Kit

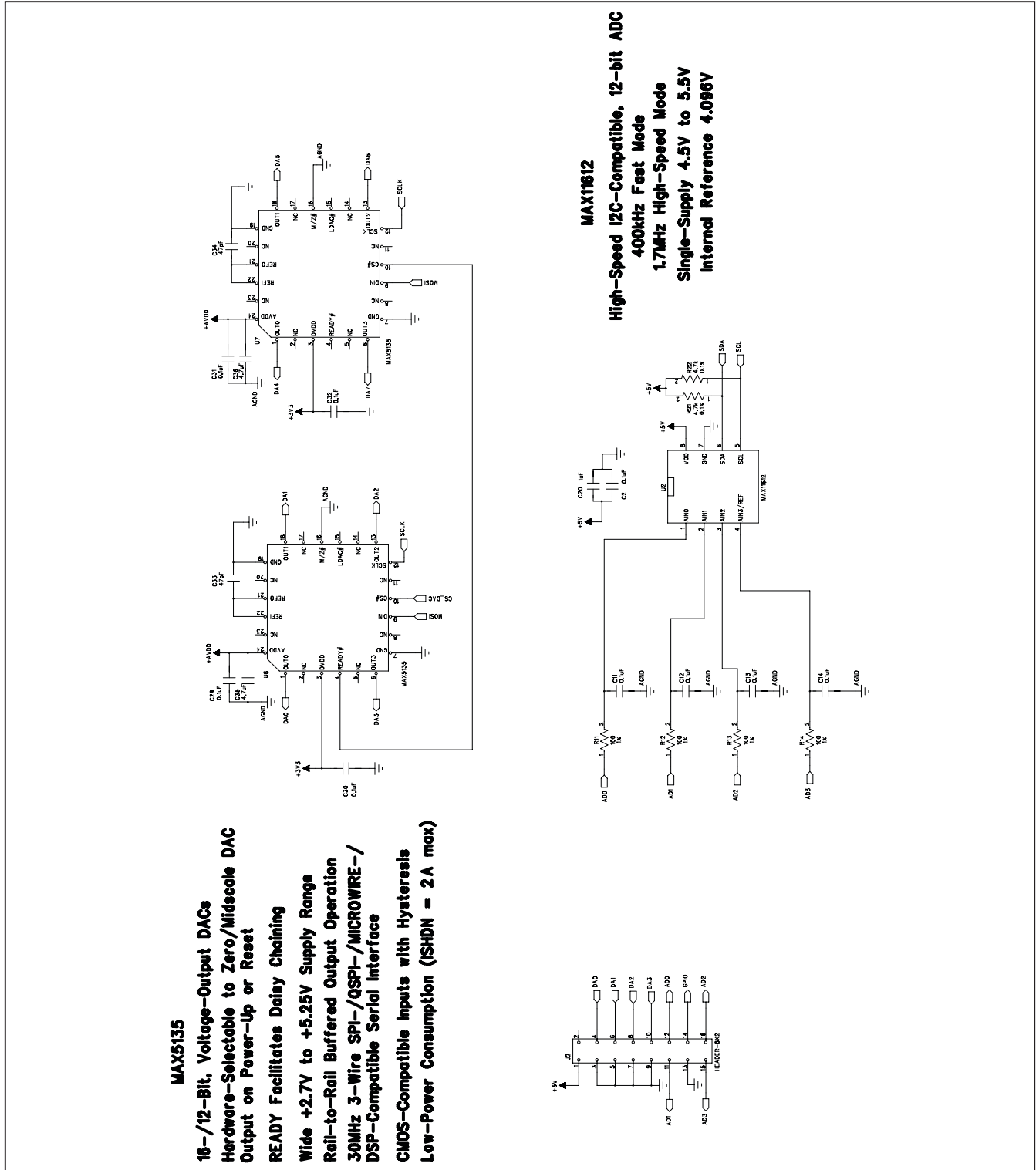

Figure 1c. MAXSPCSPARTAN6+ EV Kit Schematic (Sheet 3 of 4)

MAXSPCSPARTAN6+ Evaluation Kit

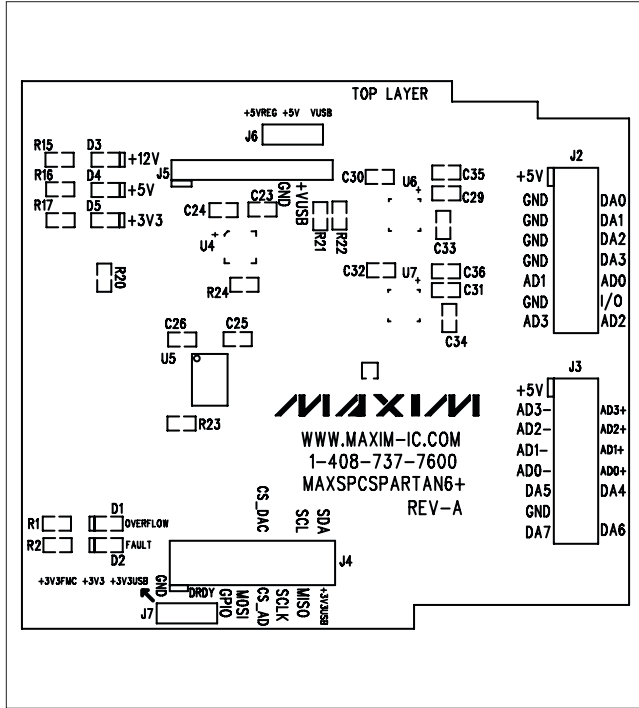

Figure 2. MAXSPCSPARTAN6+ Component Placement Guide—Component Side

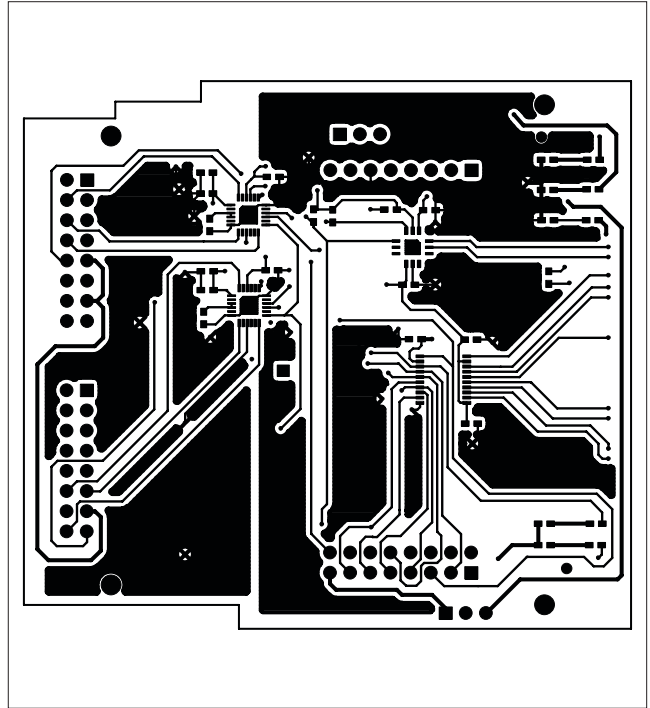

Figure 4. MAXSPCSPARTAN6+ PCB Layout—Component Side

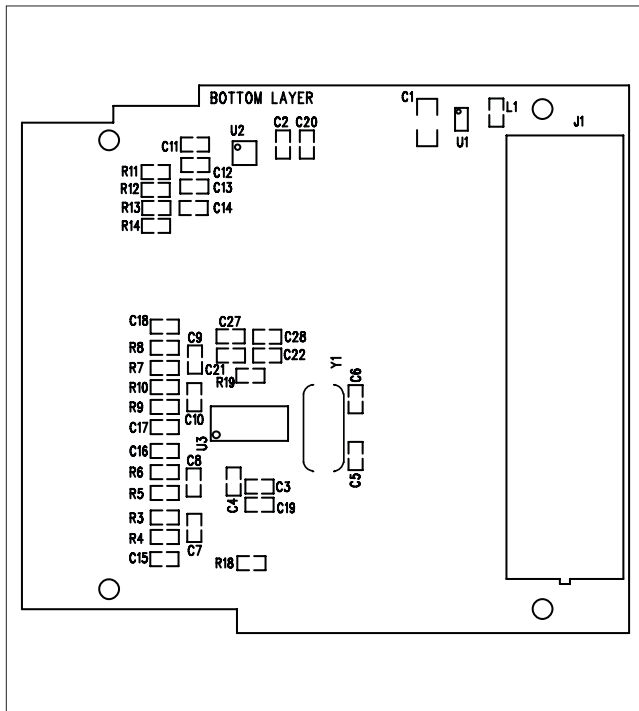

Figure 3. MAXSPCSPARTAN6+ Component Placement Guide—Solder Side

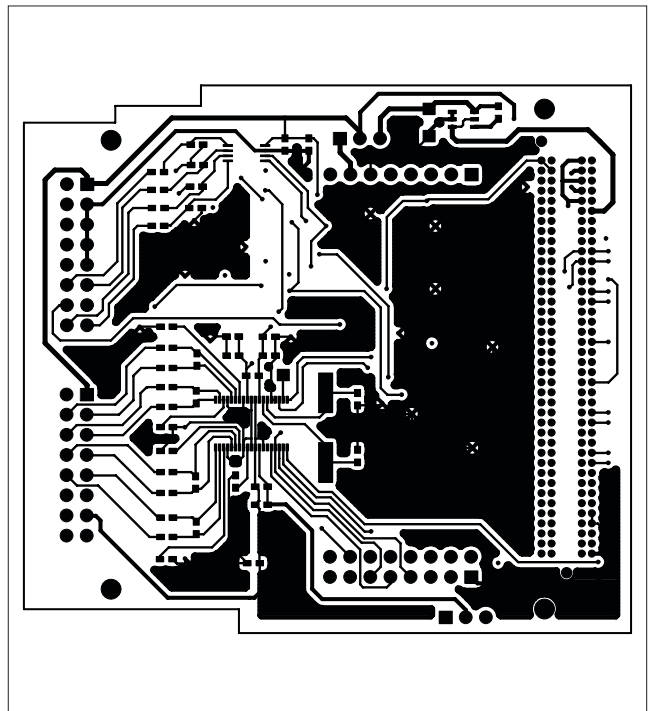

Figure 5. MAXSPCSPARTAN6+ PCB Layout—Solder Side

MAXSPCSPARTAN6+ Evaluation Kit

Revision History

REVISION NUMBER	REVISION DATE	DESCRIPTION	PAGES CHANGED
0	5/10	Initial release	—

Evaluates: MAX5135/MAX11040/MAX11612

Maxim cannot assume responsibility for use of any circuitry other than circuitry entirely embodied in a Maxim product. No circuit patent licenses are implied. Maxim reserves the right to change the circuitry and specifications without notice at any time.

Maxim Integrated Products, 120 San Gabriel Drive, Sunnyvale, CA 94086 408-737-7600 _____ 9

© 2010 Maxim Integrated Products

Maxim is a registered trademark of Maxim Integrated Products, Inc.