

THDB-SUM

Terasic HSMC to Santa Cruz Daughter Board User Manual

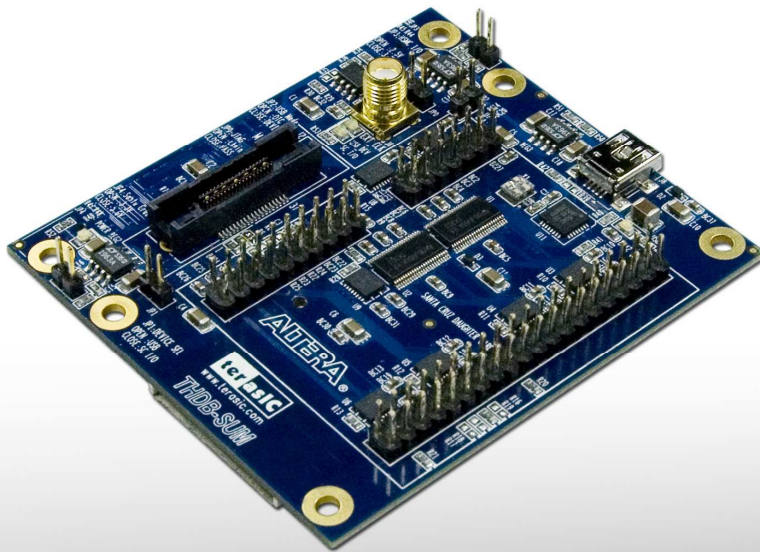

INTRODUCTION.....	1
1.1 FEATURES.....	1
1.2 GETTING HELP.....	2
ARCHITECTURE.....	3
2.1 LAYOUT AND COMPONENTS.....	3
2.2 BLOCK DIAGRAM.....	5
BOARD COMPONENTS.....	6
3.1 THE HSMC CONNECTOR.....	6
3.2 SANTA CRUZ CONNECTOR.....	10
3.3 USB ON-THE-GO TRANSCEIVER.....	14
3.4 MICTOR CONNECTOR.....	16
3.5 SD CARD INTERFACE.....	18
3.6 SMA CONNECTOR.....	19
3.7 I2C SERIAL EEPROM.....	20
3.8 POWER SUPPLY.....	21
DEMONSTRATION.....	22
4.1 CONNECTING THDB-SUM BOARD TO CYCLONE III START BOARD.....	22
APPENDIX.....	24
5.1 REVISION HISTORY.....	24
5.2 ALWAYS VISIT THDB-SUM WEBPAGE FOR NEW MAIN BOARD.....	24

1 Introduction

THDB-SUM (HSMC to Santa Cruz / USB / Mictor Daughter Board) is an adapter board to convert High Speed Mezzanine Connector (HSMC) interface to Santa Cruz (SC), USB, Mictor, and SD Card interface. It allows users to use these interface on a host board with a HSMC connector.

Because of limited I/O numbers of the HSMC interface, the SC interface and USB port have to share the same I/O pins. Users can choose which interface to be enabled by jumper selection.

Finally, the source signals from the HSMC interface to the SC header on the THDB-SUM board will be passed through level shifters to adjust the logic level difference between the HSMC and SC interface board.

Features

Figure 1.1 shows the photo of the THDB-SUM board. The important features are listed below:

- One HSMC connector for interface conversion
- One Santa Cruz interface
- Adjustable logic levels between HSMC and SC interface signals
- One Hi-Speed USB On-The-Go transceiver
- One Mictor Connector
- One SMA Connector for external clock input
- One SD Card Socket

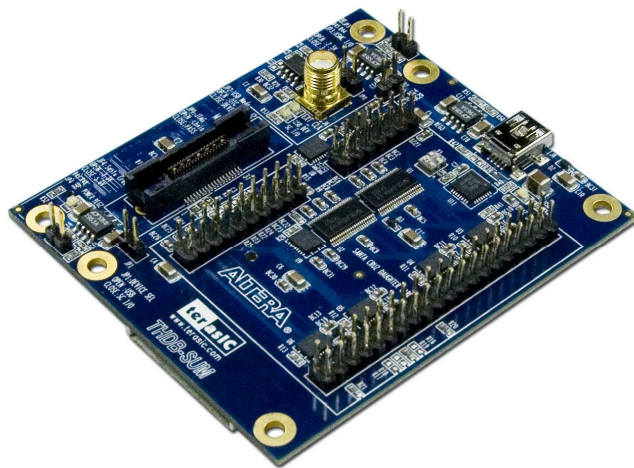

Figure 1.1. The THDB-SUM board

Getting Help

Here are some places to get help if you encounter any problem:

- ✓ Email to support@terasic.com
- ✓ Taiwan & China: +886-3-550-8800
- ✓ Korea : +82-2-512-7661
- ✓ Japan: +81-428-77-7000

2 Architecture

This chapter describes the architecture of the THDB-SUM board including its PCB and block diagram.

Layout and Components

The picture of the TDRB-SUM board is shown in Figure 2.1 and Figure 2.2. It depicts the layout of the board and indicates the location of the connectors and key components.

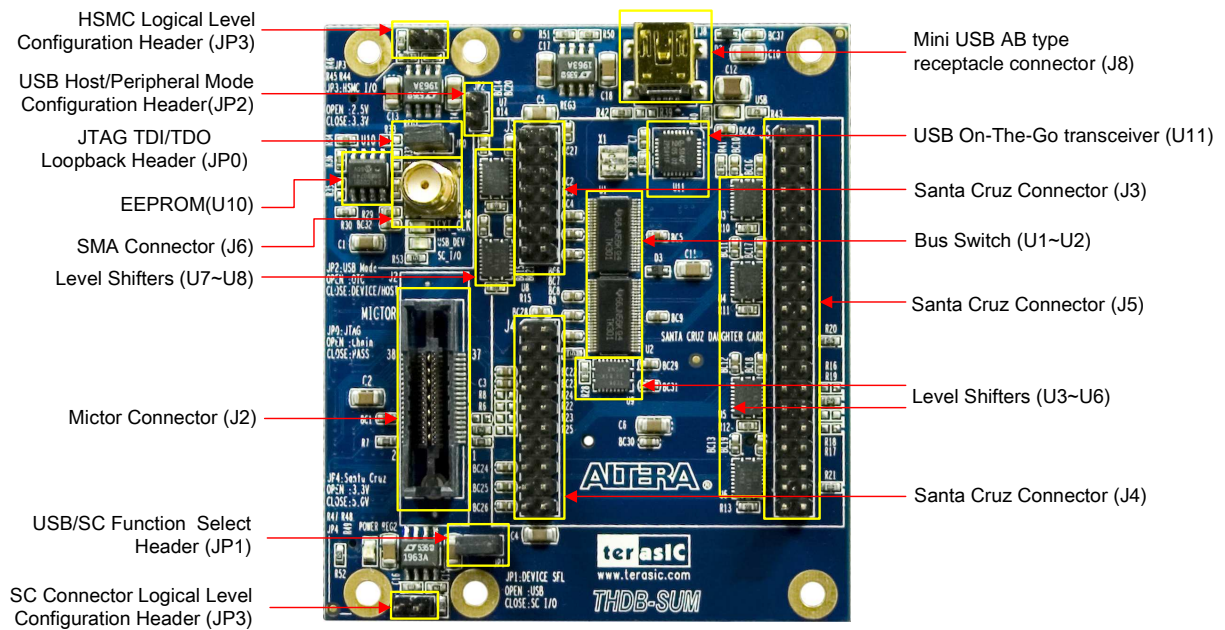

Figure 2.1. The THDB-SUM PCB and component diagram

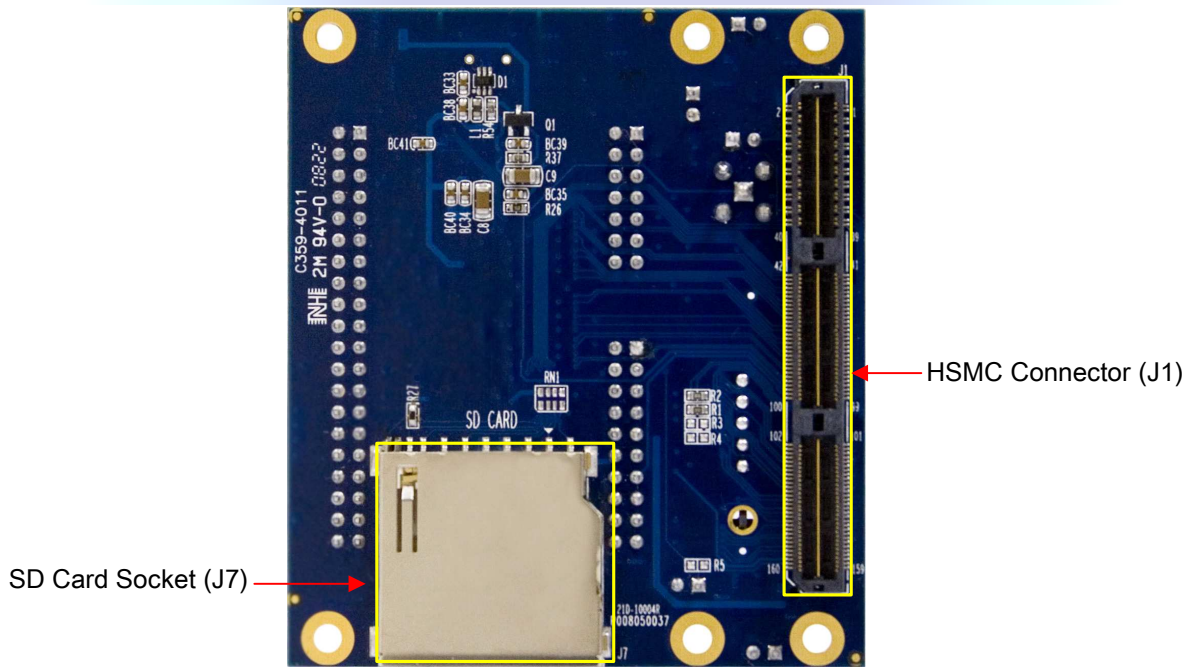

Figure 2.2. The THDB-SUM Back side – HSMC connector view

The following components are provided on the THDB-SUM board :

- HSMC expansion connector (J1)
- Santa Cruz Headers(J3,J4,J5)
- Mictor connector (J2)
- SMA connector (J6)
- Hi-Speed USB On-The-Go transceiver (U11)
 - Fully compliant with Universal Serial Bus Specification Rev. 2.0
 - Supplement to the USB 2.0 Specification Rev. 1.3
 - Supplement UTMI+ Low Pin Interface (ULPI) Specification Rev. 1.1
- Mini USB AB type receptacle connector(J8)
- Logic level configuration headers (JP3,JP4)
- SD Card socket(J7)
- I2C serial EEPROM (U10)
- Level translator (U3~U9)
- Bus Switches (U1~U2)

Block Diagram

Figure 2.3 shows the block diagram of the THDB-SUM board

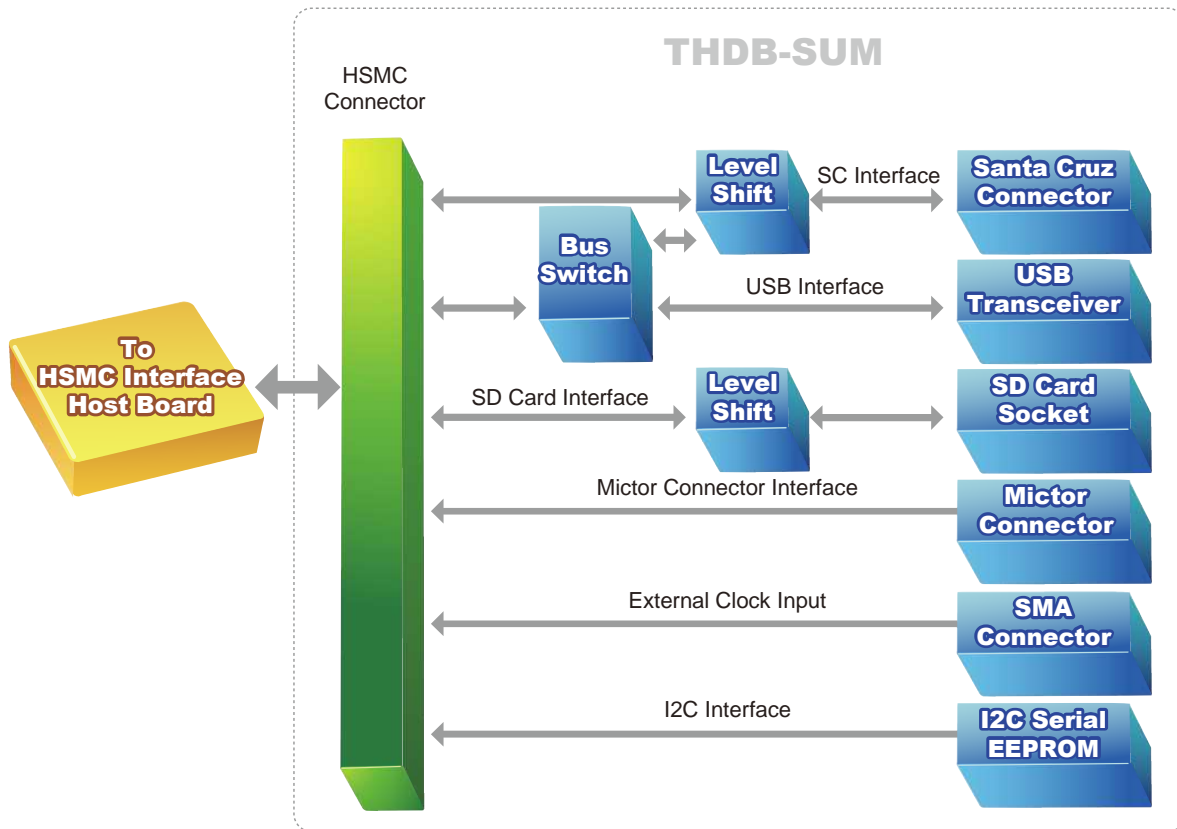

Figure 2.3. The block diagram of the THDB-SUM board

This section will describe the detailed information of the components, connector interfaces, and the pin mapping tables of the THDB-SUM board

The HSMC Connector

This section describes the HSMC connector on the THDB-SUM board

THDB-SUM board contains an Altera standard HSMC connector. All the other connector interfaces on the THDB-SUM board are connected to the HSMC connector. Figure 3.1, Figure 3.2, and Figure 3.3 show the pin-outs of the HSMC connector. Also, the JTAG interface of the HSMC connector is shown in the Figure 3.4. If users don't need to use the JTAG interface on the THDB-SUM board, please short the header JP0 to loopback the TDI and TDO signals on the HSMC connector.

Board Components

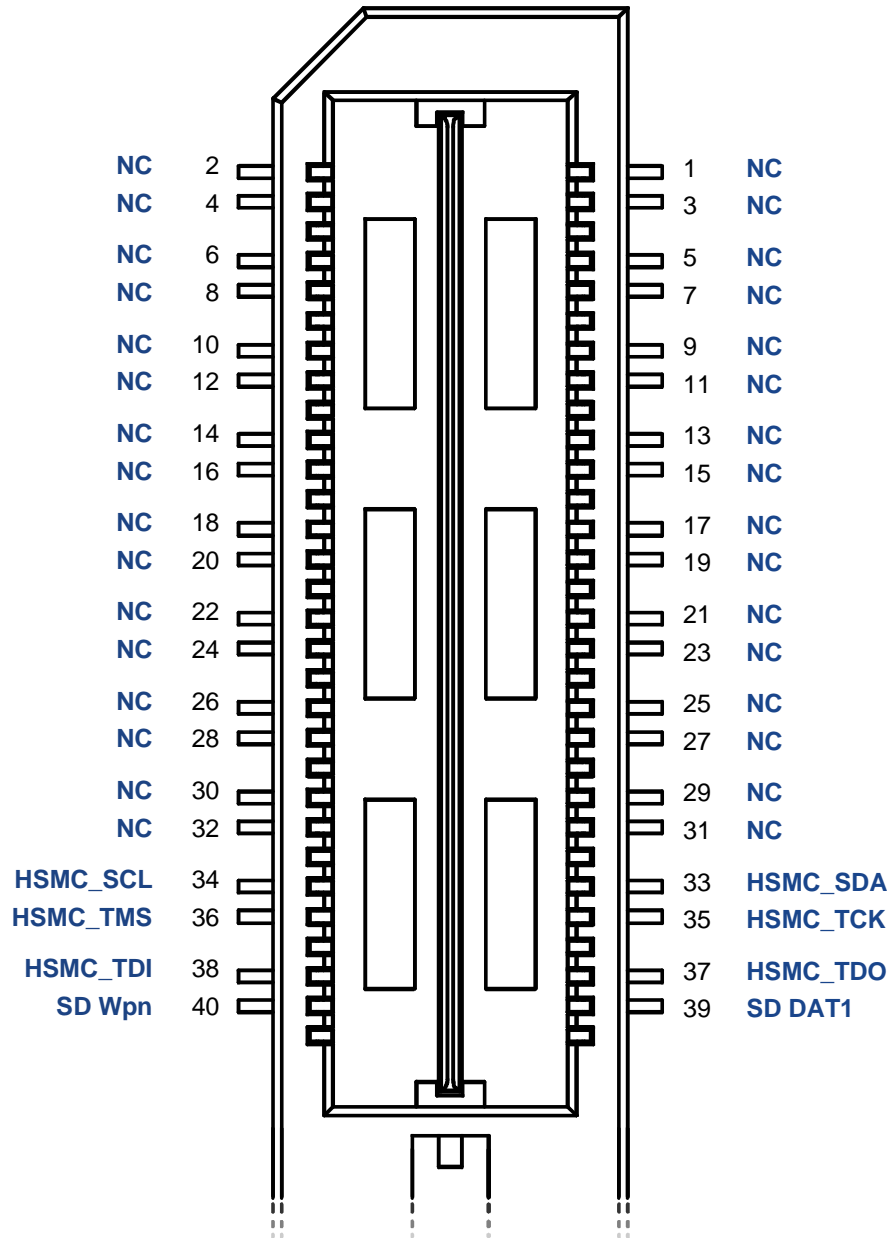

Figure 3.1. The pin-outs of Bank 1 on the HSMC connector

Board Components

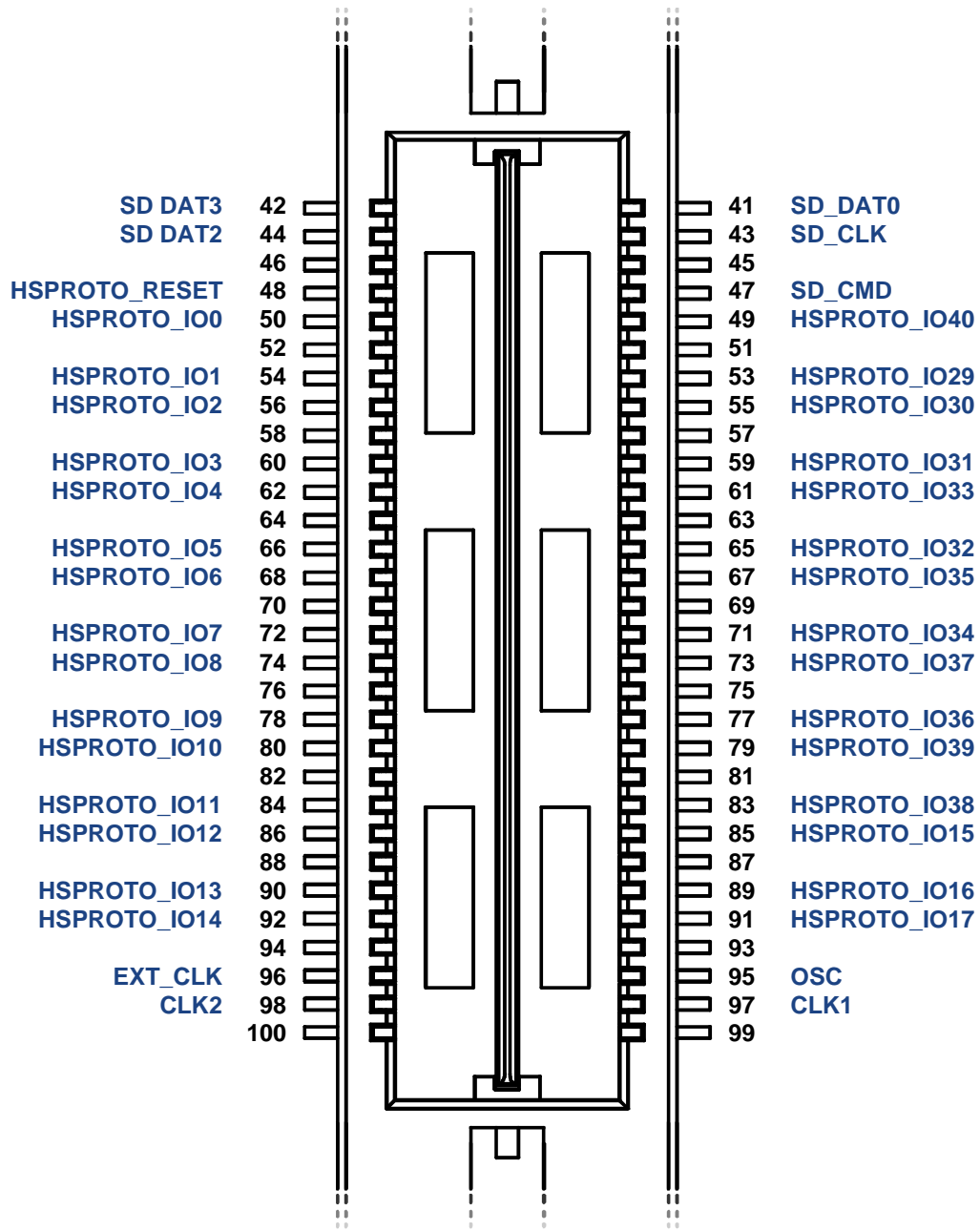

Figure 3.2. The pin-outs of Bank 2 of the HSMC connector.

Board Components

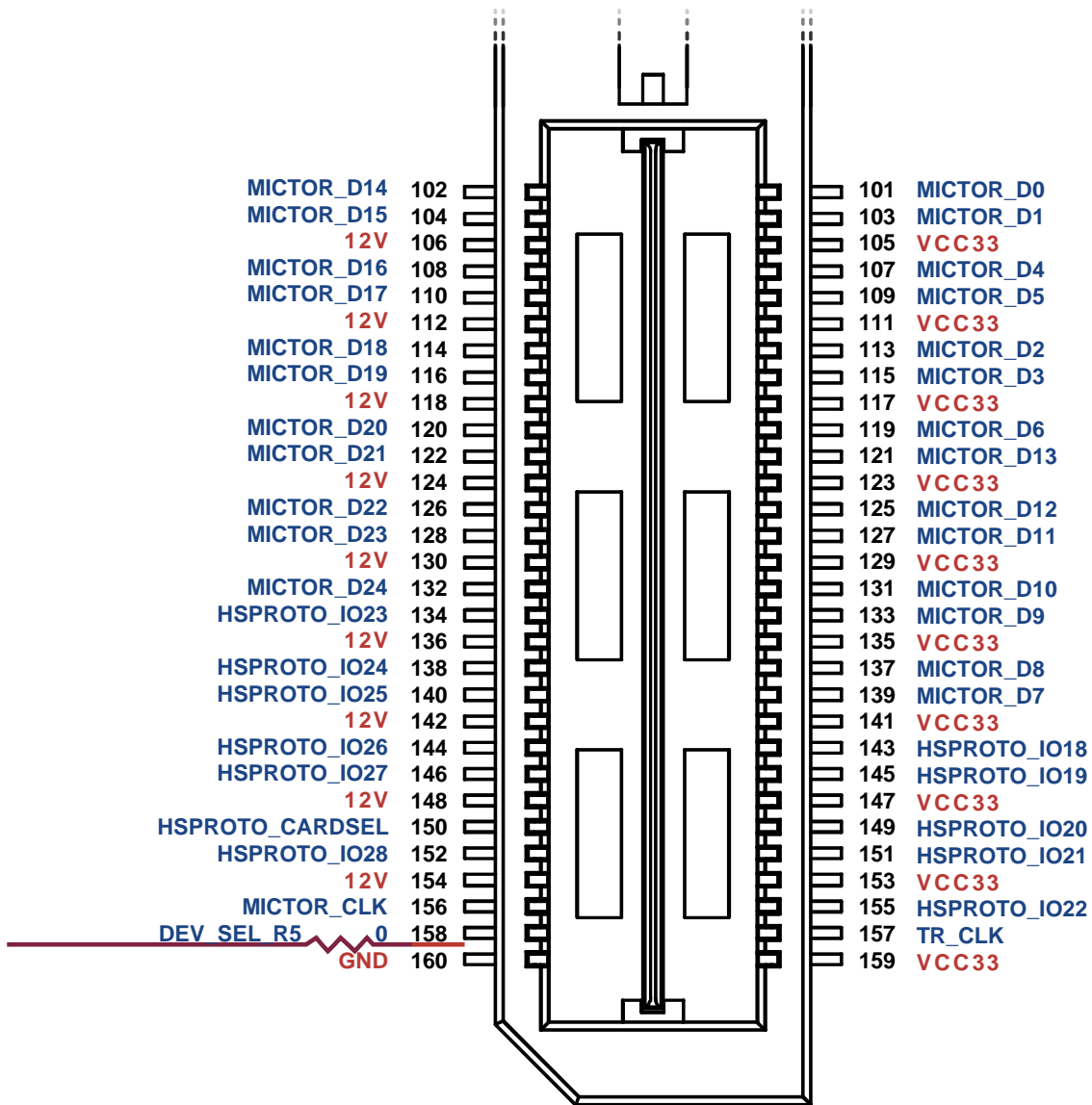

Figure 3.3. The pin-outs of Bank 3 of the HSMC connector

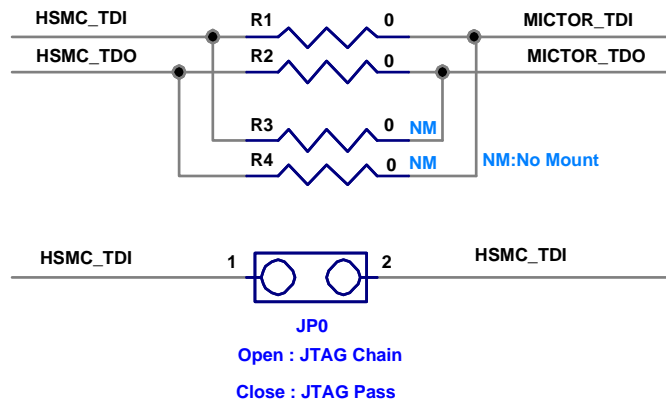

Figure 3.4. The JTAG interface setting of the HSMC connector.

Santa Cruz Connector

This section describes the Santa Cruz connector on the THDB-SUM board

The THDB-SUM board comes with Santa Cruz connectors (J3, J4 and J5) to connect to a daughter board with Santa Cruz interface. On the THDB-SUM, the pin of SC connector not directly connects with HSMC connector. Owing to the limitation of number of HSMC connector I/O pins, SC connector and USB transceiver share some I/O pins together, Please refer to [Figure 3.5](#), those I/O pass through a Bus Switch chip first and then connect with HSMC connector. Therefore users can only choose one function between SC connector and USB transceiver. Users can refer to [Table 3.1](#) and use JP2 to choose a function

In addition, from the [Figure 3.6](#), there are several level shift chips between HSMC and SC. These level shift chips convert the logic levels of the signals between the HSMC and Santa Cruz connectors according to the configurations of the headers (JP3, JP4). With this feature, users can use different I/O standards between the HSMC host board and SC interface daughter board. [Table 3.2](#) and [Table 3.3](#) list the configurations of the voltage level of the HSPROTO_IO BUS and the PROTO_IO BUS, respectively.

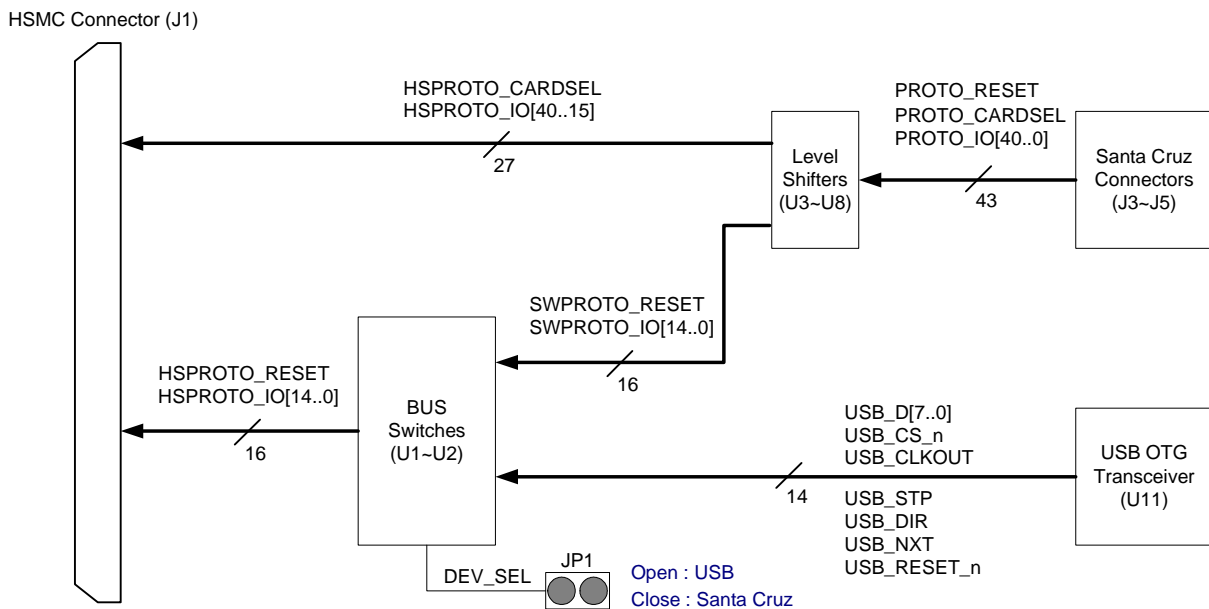

Figure 3.5. The I/O distribution of the HSMC, Santa Cruz, and USB transceiver interface.

JP1 setting	Enable Function
Open	USB OTC Transceiver
Close	Santa Cruz conenctor

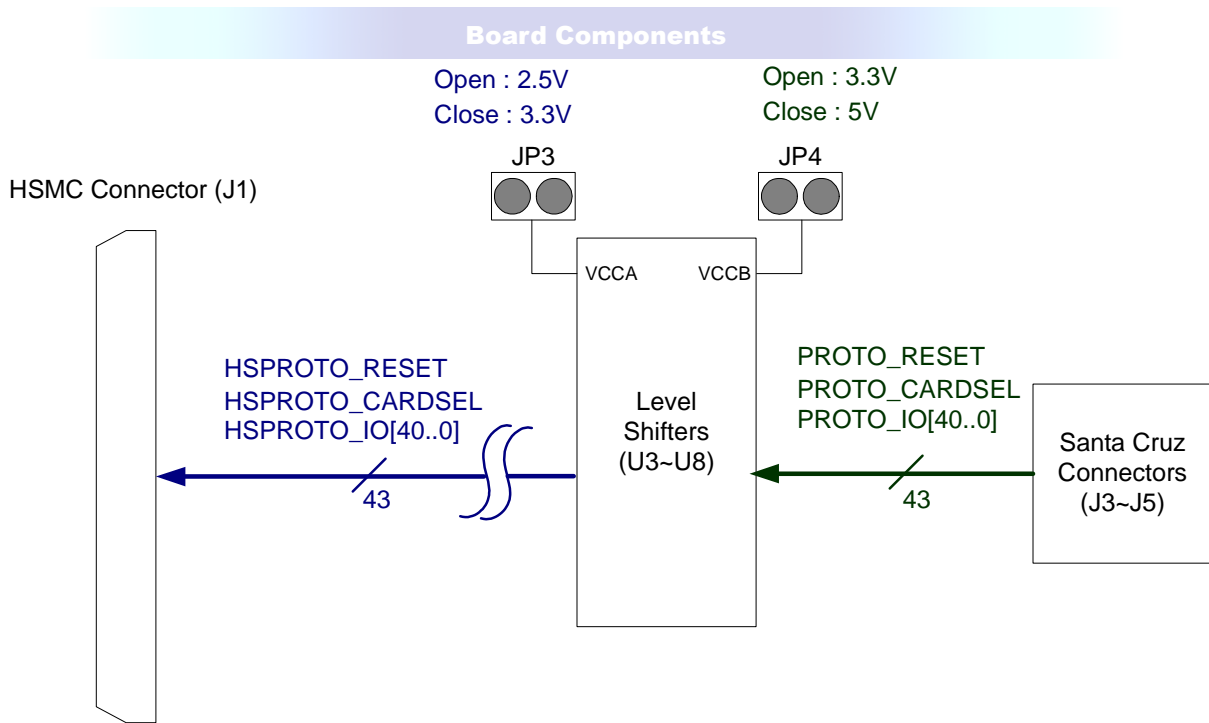

Figure 3.6 The diagram of the logic level transform block

Table 3.2 The configuration of the logic level on the HSPROTO_IO BUS	
JP3 setting	Logic level of the HSPROTO_IO BUS
Open	2.5V
Close	3.3V

Table 3.3 The configuration of the logic level on the PROTO_IO BUS	
JP4 setting	Logic level of the PROTO_IO BUS
Open	3.3V
Close	5V

Finally, [Figure 3.5](#) shows the pin-outs of the Santa Cruz connector. Detailed pin mappings between J3, J4, and J5 to the HSMC connector is listed in [Table 3.4](#), [Table 3.5](#), and [Table 3.6](#), respectively.

Note:

Because of the characteristic of the level translators, the data rate of the HSPROTO_IO and PROTO_IO bus should be under 100 Mbps.

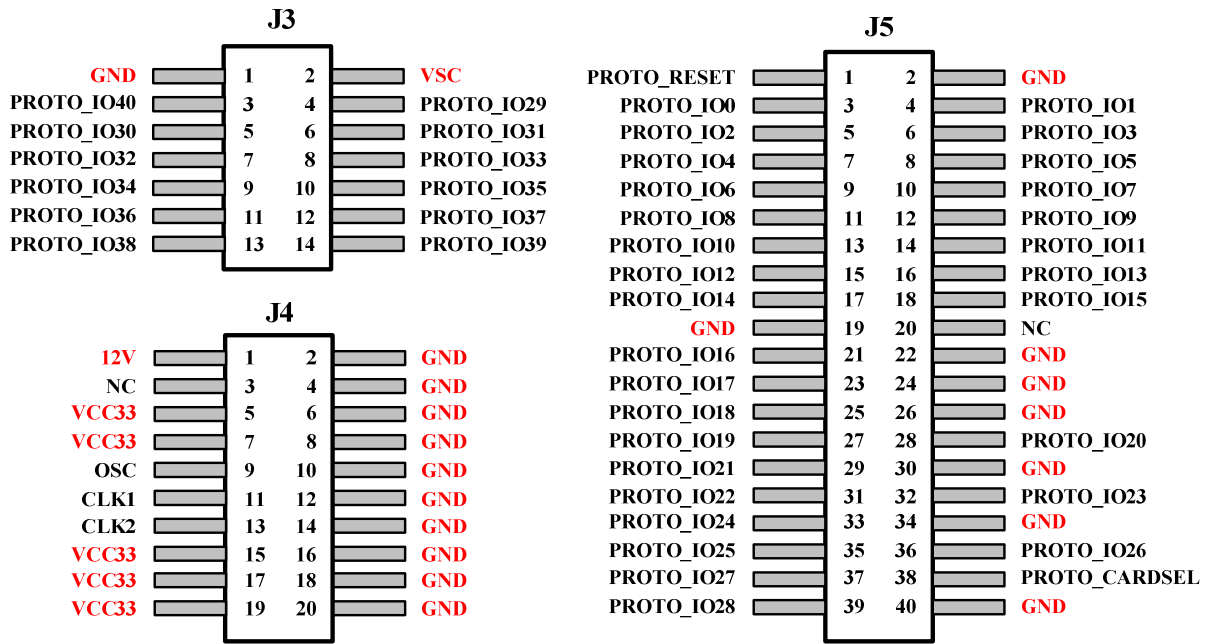

Figure 3.7 Santa Cruz connector pin-outs

Table 3.4 The pin assignments of the Santa Cruz connector J3

SC Pin Number	SC Signal Name	HSMC Pin Number	HSMC Signal Name	HSMC Pin Name
3	PROTO_IO40	49	HSPROTO_IO40	HSMC_TX_N0
4	PROTO_IO29	53	HSPROTO_IO29	HSMC_TX_P1
5	PROTO_IO30	55	HSPROTO_IO30	HSMC_TX_N1
6	PROTO_IO31	59	HSPROTO_IO31	HSMC_TX_P2
7	PROTO_IO32	65	HSPROTO_IO32	HSMC_TX_P3
8	PROTO_IO33	61	HSPROTO_IO33	HSMC_TX_N2
9	PROTO_IO34	71	HSPROTO_IO34	HSMC_TX_P4
10	PROTO_IO35	67	HSPROTO_IO35	HSMC_TX_N3
11	PROTO_IO36	77	HSPROTO_IO36	HSMC_TX_P5
12	PROTO_IO37	73	HSPROTO_IO37	HSMC_TX_N4
13	PROTO_IO38	83	HSPROTO_IO38	HSMC_TX_P6
14	PROTO_IO39	79	HSPROTO_IO39	HSMC_TX_N5

Table 3.5 The pin assignments of the Santa Cruz connector J4

SC Pin Number	SC Signal Name	HSMC Pin Number	HSMC Signal Name	HSMC Pin Name
9	OSC	95	OSC	HSMC_CLKOUT_P1
11	CLK1	97	CLK1	HSMC_CLKOUT_N1
13	CLK2	98	CLK2	HSMC_CLKIN_N1

SC Pin Number	SC Signal Name	HSMC Pin Number	HSMC Signal Name	HSMC Pin Name
1	PROTO_RESET	48	HSPROTO_RESET	HSMC_RX_P0
3	PROTO_IO0	50	HSPROTO_IO0	HSMC_RX_N0
4	PROTO_IO1	54	HSPROTO_IO1	HSMC_RX_P1
5	PROTO_IO2	56	HSPROTO_IO2	HSMC_RX_N1
6	PROTO_IO3	60	HSPROTO_IO3	HSMC_RX_P2
7	PROTO_IO4	62	HSPROTO_IO4	HSMC_RX_N2
8	PROTO_IO5	66	HSPROTO_IO5	HSMC_RX_P3
9	PROTO_IO6	68	HSPROTO_IO6	HSMC_RX_N3
10	PROTO_IO7	72	HSPROTO_IO7	HSMC_RX_P4
11	PROTO_IO8	74	HSPROTO_IO8	HSMC_RX_N4
12	PROTO_IO9	78	HSPROTO_IO9	HSMC_RX_P5
13	PROTO_IO10	80	HSPROTO_IO10	HSMC_RX_N5
14	PROTO_IO11	84	HSPROTO_IO11	HSMC_RX_P6
15	PROTO_IO12	86	HSPROTO_IO12	HSMC_RX_N6
16	PROTO_IO13	90	HSPROTO_IO13	HSMC_RX_P7
17	PROTO_IO14	92	HSPROTO_IO14	HSMC_RX_N7
18	PROTO_IO15	85	HSPROTO_IO15	HSMC_TX_N6
21	PROTO_IO16	89	HSPROTO_IO16	HSMC_TX_P7
23	PROTO_IO17	91	HSPROTO_IO17	HSMC_TX_N7
25	PROTO_IO18	143	HSPROTO_IO18	HSMC_TX_P15
27	PROTO_IO19	145	HSPROTO_IO19	HSMC_TX_N15
28	PROTO_IO20	149	HSPROTO_IO20	HSMC_TX_P16
29	PROTO_IO21	151	HSPROTO_IO21	HSMC_TX_N16
31	PROTO_IO22	155	HSPROTO_IO22	HSMC_CLKOUT_P2
32	PROTO_IO23	134	HSPROTO_IO23	HSMC_RX_N13
33	PROTO_IO24	138	HSPROTO_IO24	HSMC_RX_P14
35	PROTO_IO25	140	HSPROTO_IO25	HSMC_RX_N14
36	PROTO_IO26	144	HSPROTO_IO26	HSMC_RX_P15
37	PROTO_IO27	146	HSPROTO_IO27	HSMC_RX_N15
38	PROTO_CARDSEL	150	HSPROTO_CARDSEL	HSMC_RX_P16
39	PROTO_IO28	152	HSPROTO_IO28	HSMC_RX_N16

USB On-The-Go transceiver

This section describes the USB On-The-Go transceiver on the THDB-SUM board

The THDB-SUM is equipped with a NXP ISP1504C USB On-The-Go transceiver (U11) and Mini USB AB type receptacle connector (J8) to provide USB interface to the HSMC interface host board. The ISP1504 is a Universal Serial Bus (USB) On-The-Go (OTG) transceiver that is fully compliant with Universal Serial Bus Specification Rev. 2.0, On-The-Go Supplement to the USB 2.0 Specification Rev. 1.3 and UTMI+ Low Pin Interface (ULPI) Specification Rev. 1.1.

The pervious section, Santa Cruz Connector, has mentioned that USB transceiver and Santa Cruz connector share the I/Os which connect to HSMC connector, which means users can only choose one function between USB and Satan Cruz interface, If users would like to choose the function of USB transceiver, please turn on JP2. For more detailed information about this transceiver, please refer to the datasheet which can be found in the NXP's website.

In addition, for OTG implementations, a 2-pin header named JP1 is connected with ID (identification) pin of the USB OTG transceiver and micro-USB receptacle. As shown in [Figure 3.8](#), The logic level of the ID pin on the USB OTG transceiver can be configured to logic high or low via JP1. As defined in On-The-Go supplement to the USB 2.0 specification Rev. 1.3, the ID pin dictates the initial role of the link. If ID is detected as HIGH, the link must assume the role of a peripheral. If ID is detected as LOW, the link must assume a host role. [Table 3.7](#) shows the JP1 configuration setting for the ID.

Finally, the detailed pin mappings between the USB On-The-Go transceiver and the HSMC connector are shown in [Table3.8](#).

JP2 setting	Host or peripheral role
Open	Peripheral
Close	Host

Board Components

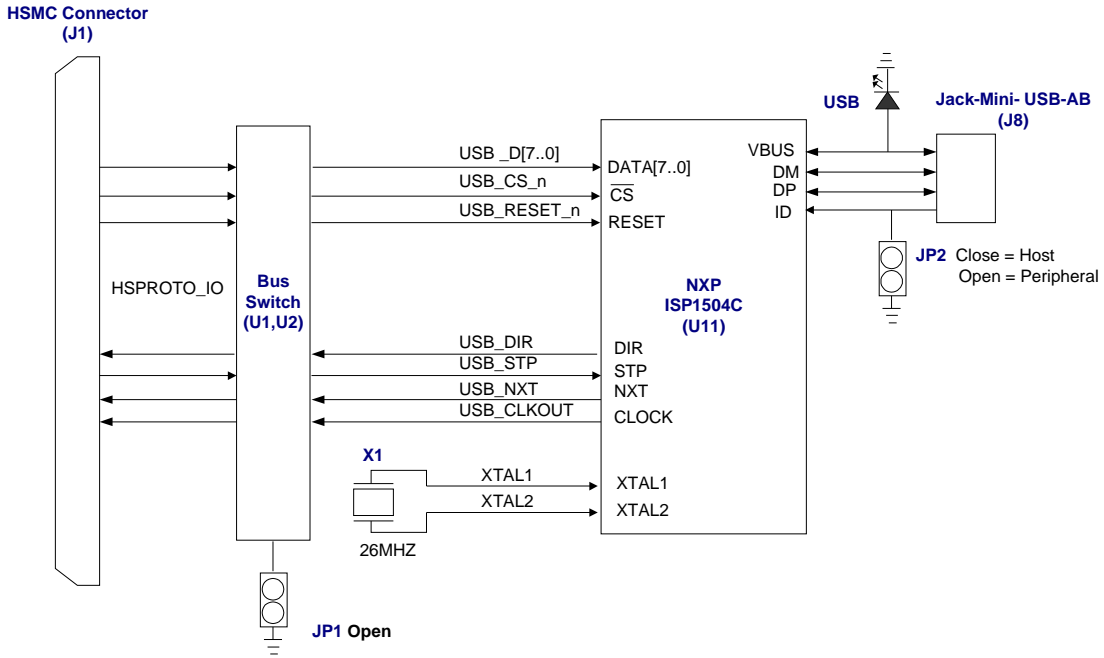

Figure 3.8 The block diagram of the USB OTG transceiver and HSMC connector

USB Pin Number	USB Signal Name	HSMC Pin Number	HSMC Signal Name	HSMC Pin Name
1	USB_D0	48	HSPROTO_RESET	HSMC_RX_P0
17	USB_RESET_n	86	HSPROTO_IO12	HSMC_RX_N6
19	USB_DIR	84	HSPROTO_IO11	HSMC_RX_P6
20	USB_STP	80	HSPROTO_IO10	HSMC_RX_N5
21	USB_NXT	78	HSPROTO_IO9	HSMC_RX_P5
23	USB_D7	74	HSPROTO_IO8	HSMC_RX_N4
24	USB_D6	72	HSPROTO_IO7	HSMC_RX_P4
25	USB_D5	68	HSPROTO_IO6	HSMC_RX_N3
26	USB_D4	66	HSPROTO_IO5	HSMC_RX_P3
27	USB_CLKOUT	62	HSPROTO_IO4	HSMC_RX_N2
28	USB_D3	60	HSPROTO_IO3	HSMC_RX_P2
29	USB_CS_n	56	HSPROTO_IO2	HSMC_RX_N1
31	USB_D2	54	HSPROTO_IO1	HSMC_RX_P1
32	USB_D1	50	HSPROTO_IO0	HSMC_RX_N0

Mictor Connector

This section describes how to use the Mictor connector on the THDB-SUM board

The Mictor connector (J2) can be used for logic analysis on the HSMC-interfaced host board by connecting an external scope or a logic analyzer to it. [Figure 3.9](#) shows the pin-outs of the Mictor connector. [Table 3.9](#) shows the detailed pin mappings between the Mictor connector and the HSMC connector.

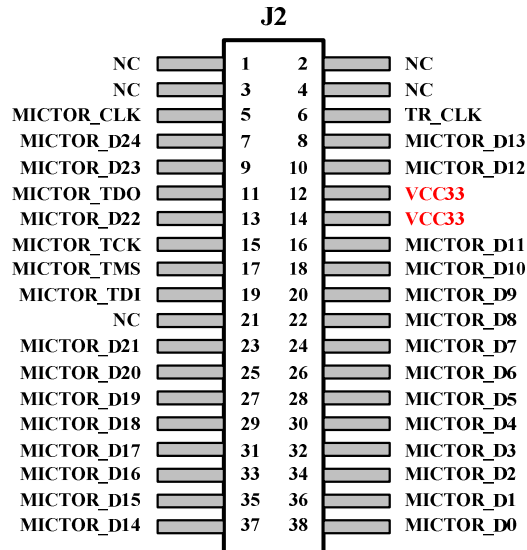

Figure 3.9 Mictor connector pin-outs

Mictor Connector Pin Number	Mictor Connector Signal Name	HSMC Pin Number	HSMC Signal Name	HSMC Pin Name
5	MICTOR_CLK	156	MICTOR_CLK	HSMC_CLKIN_P2
6	TR_CLK	157	TR_CLK	HSMC_CLKOUT_N2
7	MICTOR_D24	132	MICTOR_D24	HSMC_RX_P13
8	MICTOR_D13	121	MICTOR_D13	HSMC_TX_N11
9	MICTOR_D23	128	MICTOR_D23	HSMC_RX_N12
10	MICTOR_D12	125	MICTOR_D12	HSMC_TX_P12
13	MICTOR_D22	126	MICTOR_D22	HSMC_RX_P12
16	MICTOR_D11	127	MICTOR_D11	HSMC_TX_N12
18	MICTOR_D10	131	MICTOR_D10	HSMC_TX_P13
20	MICTOR_D9	133	MICTOR_D9	HSMC_TX_N13
22	MICTOR_D8	137	MICTOR_D8	HSMC_TX_P14
23	MICTOR_D21	122	MICTOR_D21	HSMC_RX_N11

Board Components

24	MICTOR_D7	139	MICTOR_D7	HSMC_TX_N14
25	MICTOR_D20	120	MICTOR_D20	HSMC_RX_P11
26	MICTOR_D6	119	MICTOR_D6	HSMC_TX_P11
27	MICTOR_D19	116	MICTOR_D19	HSMC_RX_N10
28	MICTOR_D5	109	MICTOR_D5	HSMC_TX_N9
29	MICTOR_D18	114	MICTOR_D18	HSMC_RX_P10
30	MICTOR_D4	107	MICTOR_D4	HSMC_TX_P9
31	MICTOR_D17	110	MICTOR_D17	HSMC_RX_N9
32	MICTOR_D3	115	MICTOR_D3	HSMC_TX_N10
33	MICTOR_D16	108	MICTOR_D16	HSMC_RX_P9
34	MICTOR_D2	113	MICTOR_D2	HSMC_TX_P10
35	MICTOR_D15	104	MICTOR_D15	HSMC_RX_N8
36	MICTOR_D1	103	MICTOR_D1	HSMC_TX_N8
37	MICTOR_D14	102	MICTOR_D14	HSMC_RX_P8
38	MICTOR_D0	101	MICTOR_D0	HSMC_TX_P8
11	MICTOR_TDO	37	HSMC_TDO	HSMC_TDO
15	MICTOR_TCK	35	HSMC_TCK	HSMC_TCK
17	MICTOR_TMS	36	HSMC_TMS	HSMC_TMS
19	MICTOR_TDI	38	HSMC_TDI	HSMC_TDI

To use this interface, user needs to configure the JTAG interface on the HSMC interface host board. For example, the steps of controlling the Cyclone III start board using Mictor interface is shown below:

1. Connecting the THDB-SUM board to the Cyclone III Start Board.
2. Removing the jumpers of JP1 and JP2 of the Cyclone III Start Board to connect the JTAG interface between Cyclone III FPGA and the THDB-SUM board.
3. Short the TDI and TDO pins of the JTAG connector(J4), as shown in [Figure 3.10](#)
4. Disable the built-in USB blaster by shorting JP8 on the Cyclone III Starter Board

The above FOUR steps will make a closed JTAG chain as shown in [Figure 3.11](#)

Board Components

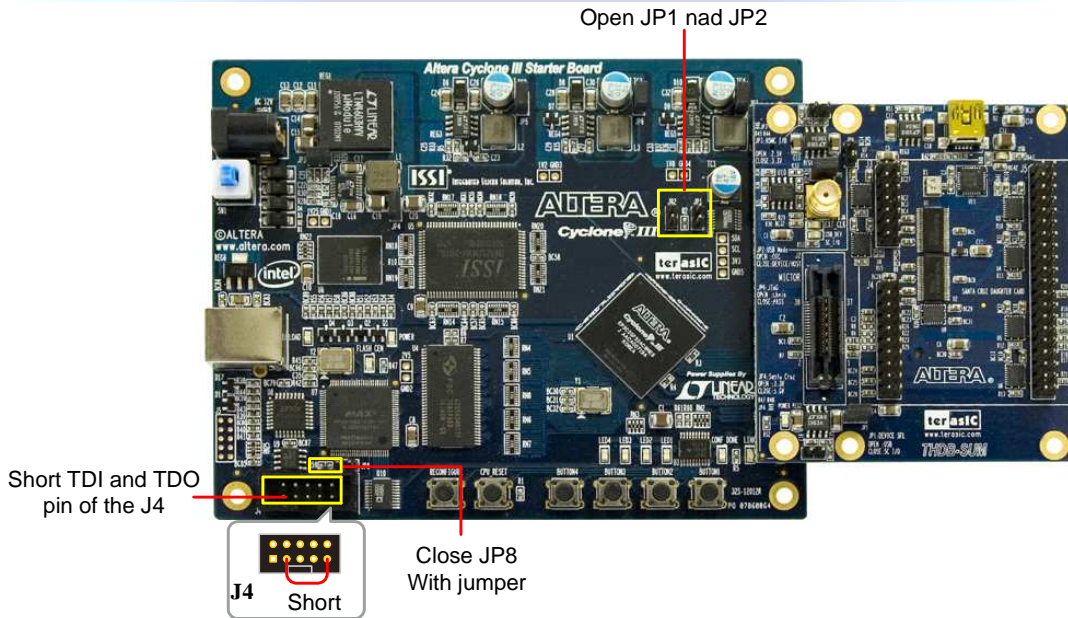

Figure 3.10 The configuration of the Cyclone III start board for controlling the JTAG chain using the Mictor connector

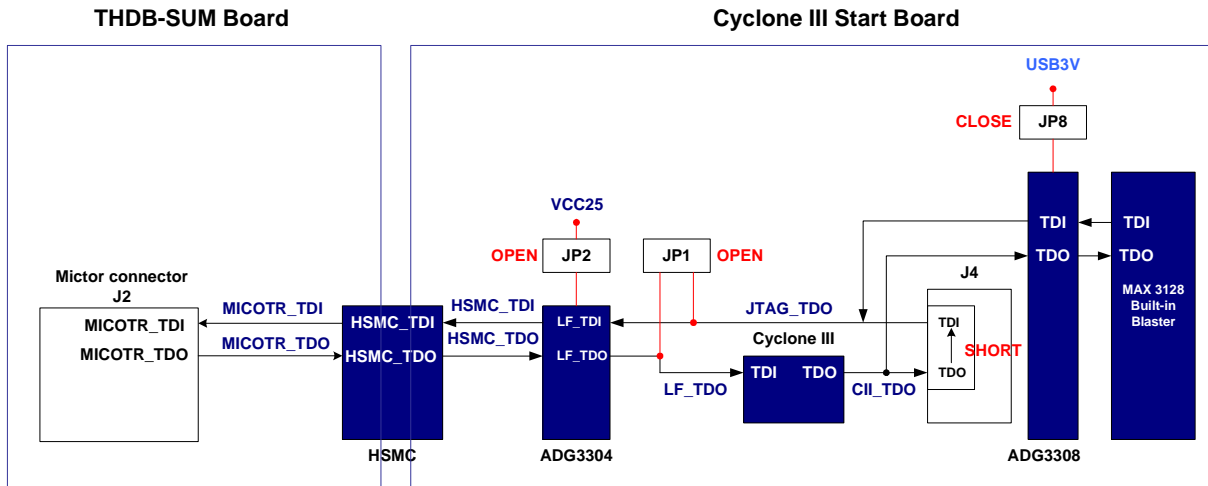

Figure 3.11 The JTAG chain between the THDB-SUM board and Cyclone III Start Board

SD Card Interface

This section describes the SD Card Interface on the THDB-SUM board

The THDB-SUM has a SD card socket and can be accessed as optional external memory in both SPI and 1-bit SD mode. Table X shows the pinout of the SD card socket with HSMC connector. Figure 3.12 and Table 3.10 shows the pin connection and pin-out between the Mictor connector and HSMC connector, respectively.

HSMC Connector

SD Card Socket

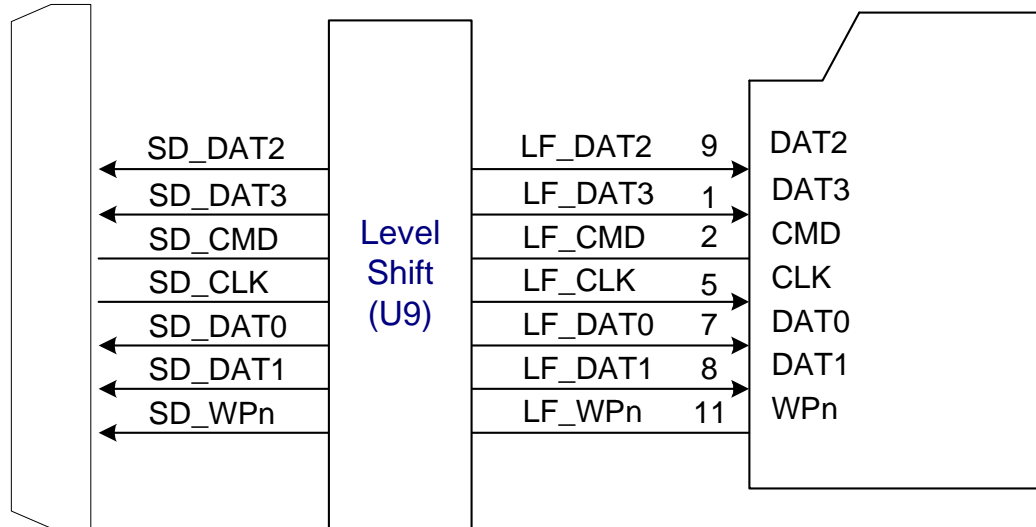

Figure 3.12 The block diagram of the SD Card socket and HSMC connector

SD Card Socket Pin Number	SD Card Socket Signal Name	HSMC Pin Number	HSMC Signal Name	HSMC Pin Name
1	LF_DAT3	42	SD_DAT3	HSMC_D1
2	LF_CMD	47	SD_CMD	HSMC_TX_P0
5	LF_CLK	43	SD_CLK	HSMC_D2
7	LF_DAT0	41	SD_DAT0	HSMC_D0
8	LF_DAT1	39	SD_DAT1	HSMC_CLKOUT0
9	LF_DAT2	44	SD_DAT2	HSMC_D3
11	LF_WPn	40	SD_WP_N	HSMC_CLKIN0

SMA Connector

This section describes the SMA connector on the THDB-SUM board

The THDB-SUM board provides a SMA connector (J6) for external clock input. The pin assignments of the SMA connector are shown in [Table 3.11](#).

SD Card Socket Pin Number	SD Card Socket Signal Name	HSMC Pin Number	HSMC Signal Name	HSMC Pin Name
1	EXT_CLK	96	EXT_CLK	HSMC_CLKIN_P1

I2C Serial EEPROM

This section describes the I2C Serial EEPROM on the THDB-SUM board

The THDB-SUM board provides an EEPROM (U10) which can be configured by the I2C interface. The size of the EEPROM is 128 bit that can store the board information or user's data. The detailed pin description between EEPROM and HSMC connector is listed in the [Table 3.12](#).

HSMC Connector

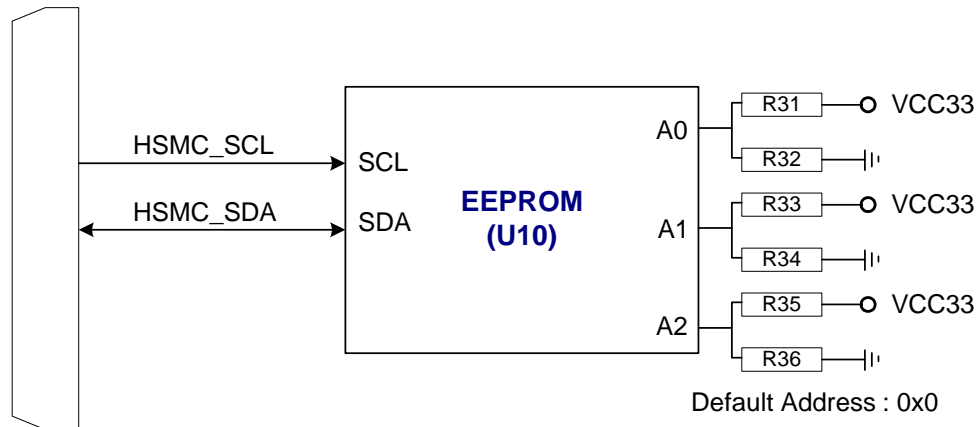

Table 3.13 The block diagram of the EEPROM and HSMC connector

EEPROM Pin Number	EEPROM Signal Name	HSMC Pin Number	HSMC Signal Name
5	HSMC_SDA	33	HSMC_SDA
6	HSMC_SCL	34	HSMC_SCL

Power Supply

This section describes the power supply on the THDB-SUM board

The power distribution on the THDB-SUM board is shown in [Figure 3.14](#).

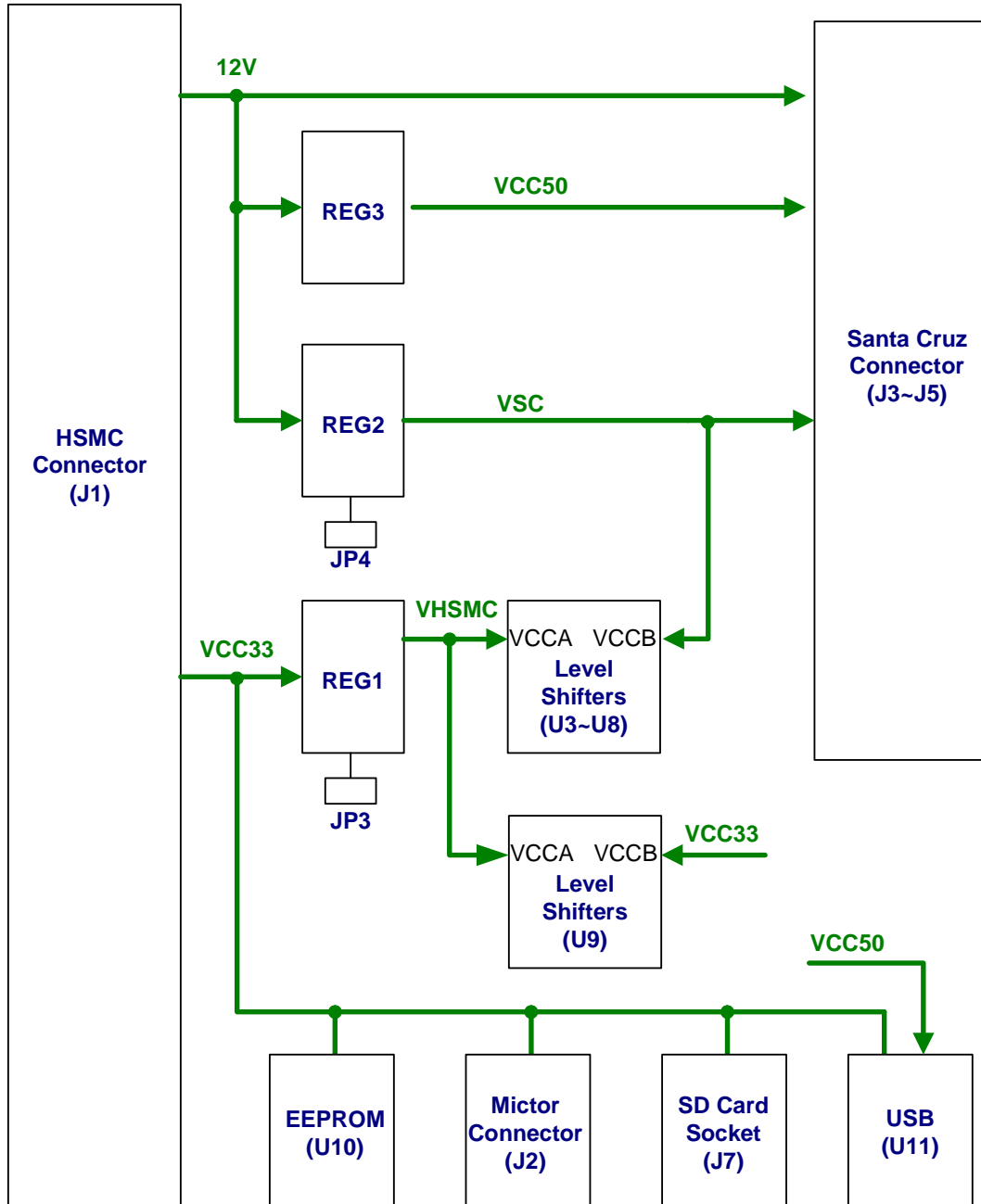

Figure 3.14. THDB-SUM board power distribution diagram.

4 Demonstration

This chapter illustrates how to connect the THDB-SUM board to a HSMC interface host board using a Cyclone III Starter Board as an example

Connecting THDB-SUM Board to Cyclone III Start Board

This section describes how to use THDB-SUM board the Cyclone III start board and what users need to know during the operation

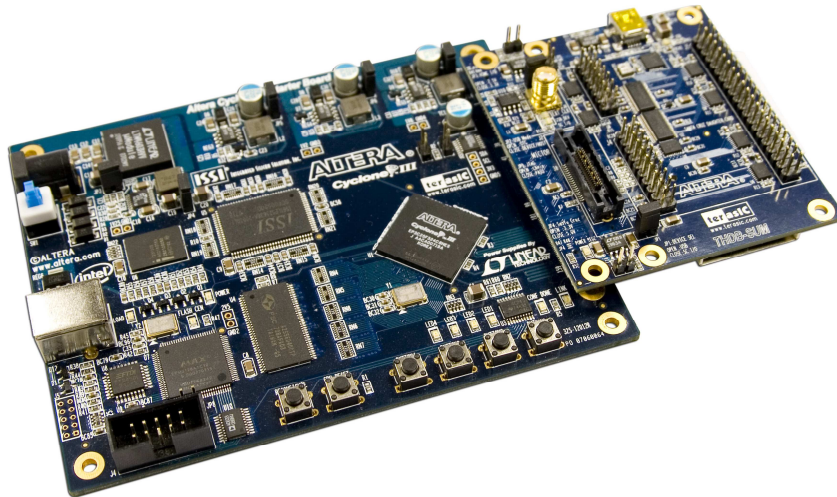

Figure 4.1 Connecting the THDB-SUM board to the Cyclone III start board

To correctly operate the THDB-SUM board with the Cyclone III start board, users need to pay attention to the following notes:

1. Observe the orientation of the HSMC connector when connecting the THDB-SUM to the Cyclone III Starter Board.
2. Users **MUST** short Pin 1 and Pin 2 of the JP3 on the THDB-SUM to force the voltage level to 2.5V to match the 2.5V IO pins of the Cyclone III board.
3. Configure JP4 of the THDB-SUM according to the logic level of the Santa Cruz daughter board (refer to Table 3.2)
4. Please note that there are two LVDS pairs on the HSMC connector: the HSMC_CLK_p1/n1 (form a

Demonstration

close loop via R3) and HSMC_CLKIN_p2/n2 (form a close loop via R4). Therefore, using any one of the signal in a LVDS pair under single-ended mode will prevent users from using the other signal in the same pair.

Revision History

Date	Change Log
SEP 3, 2008	Initial Version
MAR 13,2009	Modify Figure 3.3
DEC 2, 2009	Corrections for tables 3.1 & 3.7. Modify Ch.4 section

Always Visit THDB-SUM Webpage for New Main board

We will be continuing providing interesting examples and labs on our THDB-SUM

webpage. Please visit www.altera.com or SUM.terasic.com for more information.