

NOV

2005

Microchip Technology Incorporated



MICROSOLUTIONS

IN THIS ISSUE

PAGE 1

[Microchip Announces First Family of 16-bit PIC® Microcontrollers: Builds on Success of World's #1 8-bit MCU Architecture*](#)

PAGE 2

[Microchip Announces dsPIC33 Digital Signal Controller Family, Including 27 New dsPIC33 Devices](#)

PAGE 3

[Microchip Unveils 64-pin LCD Microcontroller Capable of Driving 168 LCD Segments](#)

PAGE 4

[High Resolution A/D Conversion with PIC® Microcontrollers](#)

PAGE 5

[Sometimes Noise Can Be Good](#)

[Analog Featured Product: MCP3605/6 Energy Measurement ICs](#)

PAGE 6

[See How Easy it is to Start Designing with Baseline and Mid-Range Microcontrollers :](#)

PAGE 7

[Enter the START NOW Design Contest](#)

PAGE 8-9

[Tips & Tricks: LCD PICmicro® Microcontrollers](#)

PAGE 10

[Archived Web Seminars](#)

PAGE 11-12

[What's New in Microchip Literature?](#)

PAGE 13

[Web Highlights](#)

Do You Need More Performance, Memory, I/O and Peripherals While Maintaining Compatibility With Microchip's MPLAB® Integrated Development Environment?



Meeting the design challenges that engineers face is the primary objective of the PIC24 family. Just as we have in the 8-bit microcontroller arena, we plan to rapidly expand the 16-bit PIC24 family to meet our customers' ever-growing needs.

Are you faced with the ever-growing challenge to meet market demands for increased performance and features at a fast pace, while hitting design-to-cost goals? The new PIC24 cost-effectively provides a step up in performance, memory size (Flash and RAM), pin counts and peripherals. The PIC24 delivers increased performance without sacrificing the architecture attributes that embedded designers require, including interrupt flexibility and responsiveness, code execution predictability, easy I/O manipulation, C code efficiency and system integrity.

Microchip is pleased to announce its first family of 16-bit PIC® microcontrollers to address the growing performance needs of embedded designers.

The new PIC24 16-bit microcontroller family debuts with 22 general-purpose devices and offers up to 40 MIPS performance, 16 Kbytes of RAM and 256 Kbytes of Flash program memory, and up to 100-pin packages. The PIC24 maintains compatibility with Microchip's universal MPLAB Integrated Development Environment (IDE) development tool platform and software compatibility with all dsPIC® digital signal controllers, including the new dsPIC33F family, for a simplified upward migration path.

The PIC24 Family is comprised of two series. The PIC24F offers a cost-effective step up in performance, memory and peripherals for many applications that are pushing the envelope of 8-bit microcontroller capabilities. For more demanding applications, the PIC24H offers 40 MIPS performance, more memory and additional peripherals, such as CAN communication modules.

Product Applications

- **Consumer** - security-system control panel, hand-held remote control
- **Communications** - optical network components
- **Instrumentation/measurement** - hand-held and remote terminals, POS terminals, medical instruments and monitoring
- **Industrial** - factory automation systems, building monitor and control systems, security/access systems, office automation

Product Features

- PIC24F: 16 MIPS, cost-effective
- Two ports each of UART, SPI™ and I²C™
- PIC24H: 40 MIPS, highest performance
- Up to two CAN ports
- 64 to 256 Kbytes of Flash program memory
- Real Time Clock Calendar (RTCC)
- 8 to 16 Kbytes of RAM
- DMA on PIC24H
- 64- to 100-pin package options with JTAG
- Analog-to-Digital Converter: PIC24F: 16-channel, 10-bit, 500 ksps
PIC24H: 2, 16-channel, 12-bit, 500 ksps

Development Tools and Availability

The PIC24 family is supported by the following Microchip development tools: MPLAB Integrated Development Environment (IDE), MPLAB C30 C Compiler, MPLAB PM3 Universal Device Programmer. Additionally, the Explorer 16 Development Board (part # DM240001) supports all 16-bit PIC24 microcontrollers and 16-bit dsPIC digital signal controllers. Finally, third-party support for the PIC24 family is planned for calendar Q4 2005, including Hi-Tech's C compiler, and a programmer from DATA I/O.

Selected members of the new PIC24F family are available today for early-adopter sampling. General sampling for all 22 of the PIC24F and PIC24H microcontrollers is expected to begin in Q1 2006, and volume production is planned to start in Q2 2006.

For more information visit: www.microchip.com/16bit

[RETURN TO FRONT PAGE](#)

www.microchip.com

Microcontrollers • Digital Signal Controllers • Analog • Serial EEPROMs

Looking for higher levels of performance, memory and I/O without the complexity of traditional Digital Signal Processors (DSPs)?



Microchip's new dsPIC33 Digital Signal Controller (DSC) architecture gives you a cost-effective solution for applications requiring large memory, I/O or substantial performance at 3.3 volts.

Microchip has expanded its line of dsPIC® DSCs with the introduction of the dsPIC33 family. These devices operate at 40 MIPS, with family members ranging from 64 to 256 Kbytes of self-programming Flash, 8 to 30 Kbytes of RAM and 64- to 100-pin packages. The dsPIC33 features an 8-channel DMA and some versions have two 1.1 Msps A/D converters. Additionally, the new

dsPIC33 family has the same instruction set as the dsPIC30 family and uses the same universal MPLAB® development tools that are common to all of Microchip's microcontroller families.

If you need to employ advanced algorithms in a control environment and find that 16-bit DSPs don't have the ability to sustain performance required for typical interrupt-intensive embedded-control applications, look no further. The dsPIC33 provides DSP levels of performance and large amounts of memory in a microcontroller-centric architecture that is ideal for embedded control. To provide further cost effectiveness and ease-of-design, the dsPIC33 is fully compatible with Microchip's universal MPLAB Integrated Development Environment (IDE), and the MPLAB C30 C compiler.

"With their dsPIC® DSCs and PIC24 MCUs, Microchip is the only company on the planet with truly unified DSP and MCU product lines. The dsPIC33 family gives MCU people an easy migration path to DSP performance."

— Will Strauss, President,
Forward Concepts

"The addition of 27 new dsPIC33 Flash-based DSCs to the 21 existing dsPIC30 DSCs signals our commitment to the market," said Sumit Mitra, vice president of Microchip's Digital Signal Controller Division.

Two dsPIC33 product lines are being brought to market: (1) General Purpose DSCs and (2) Motor Control and Power Conversion DSCs

These devices share the following key features:

- 40 MIPS deterministic performance
- Serial I/O subsystems, including up to two each: SPI™, I²C™, UART and CAN
- 64 to 256 Kbytes Flash
- 8 to 30 Kbytes RAM
- 64- to 100-pin TQFP packages
- DMA
- 3.3V operation

dsPIC33 General Purpose DSCs

Fifteen dsPIC33 general-purpose devices have been introduced. Key features that are specific to this family include:

- One or two 500 ksps, 12-bit A/D converters
- Codec interface

Product Applications

- Two-way radios, hands-free kits, answering machines, speech and audio playback applications, power-line modems, security systems and portable medical monitoring equipment

dsPIC33 Motor Control and Power Conversion DSCs

Twelve dsPIC33 motor control and power conversion devices have been introduced. Key features that are specific to this family include:

- One or two 1.1 Msps 10-bit A/D converters with up to 8 sample and holds for simultaneous sampling
- Specialized PWM for motor control, lighting and power conversion applications
- Quadrature Encoder Interface

Product Applications

- Sewing machines, LED lighting arrays, washing machines, access control, online UPS, environmental control, electronically assisted power steering, precision manufacturing equipment, absolute encoders and resolvers, inverters and electric vehicles.

Development Tools Support and Availability

Within the MPLAB® IDE, high-level resources are added in a microcontroller-friendly way to allow the utilization of DSC features with minimal effort. These features include Microchip's Visual Device Initializer, which can generate initialization code in a few clicks, and the motor control GUI, which can be used to quickly tune dsPIC® DSC motor control libraries to a specific motor type. Sophisticated libraries have been developed which fully exploit the dsPIC DSC's capabilities while presenting a user-friendly environment for engineers. Many libraries are free, while others can be licensed for a low, one-time fee. One area gaining popularity is the use of digital filters. The low-cost Digital Filter Designer and the free dsPICworks™ software can help users define filters to their specifications, simulate performance and generate code, all without immersion in DSP theory.

Selected members of the new dsPIC33 family are available today for early-adopter sampling. General sampling for all 27 of the dsPIC33 devices are expected to begin in Q1 2006, and volume production is planned to start in Q2 2006.

For more information visit: www.microchip.com/16bit

[RETURN TO FRONT PAGE](#)

A 64-pin LCD Microcontroller Capable of Driving 168 LCD Segments



Does your application require a cost-effective PIC® microcontroller with Flash reprogrammability, integrated LCD module and nanoWatt technology?

“The high level of integration for the PIC16F946 enables design engineers to develop cost-effective compact solutions with ease.” — Steve Drehobl, Vice President, Microchip's Security, Microcontroller and Technology Development Division

Microchip's new **PIC16F946** PIC microcontroller combines an integrated Liquid Crystal Display (LCD) module with lower power consumption and a high level of peripheral integration to reduce your total system cost in many consumer applications. The PIC16F946 adds to Microchip's LCD PIC microcontroller family, providing easy access to varying pin counts and levels of performance, and support for a wide selection of LCD segments.

The PIC16F946 features nanoWatt Technology, which meets industry low-power design requirements, should you need to drive LCD displays in standby conditions. Integrated peripherals include high-endurance data EEPROM, a stable internal oscillator, a 10-bit analog-to-digital converter, serial communications peripherals and the ability to implement a low-power real time clock.

Product Applications

- **Automotive** - dashboard displays
- **Instrumentation/measurement** - medical instruments/monitors, meter reading, hand-held terminal/remote reading
- **Appliance** - display/control units on stoves/ovens, microwaves
- **Industrial** - payment systems, water/gas/electric/heat utility meters, gasoline pumps
- **Consumer** - universal remote controls, programmable thermostats/controls, irrigation control, home security systems, exercise equipment
- **Communications** - handset displays



The **PICDEM™ LCD Development Board** (part # DM163028) demonstrates Microchip's family of microcontrollers with an integrated LCD driver module. Populated with the PIC18F8490 and designed for flexibility, this board supports additional LCD PIC® microcontrollers.

For complete information on LCD-specific emulation and development products, please visit the LCD Design Center at www.microchip.com/lcd.

Product Features

- 14 Kbytes of Flash program memory, 336 Bytes of RAM and 256 Bytes of data EEPROM
- Reliable low-power operation with Brownout Reset (BOR), extended Watchdog Timer (WDT), Programmable Low Voltage Detect (PLVD) and nanoWatt technology power-management modes
- Enhanced LCD module with four multiplex commons and up to 42 segment drivers
- High-stability, 8 MHz internal oscillator
- 5 MIPS core performance
- 10-bit analog-to-digital converter with up to 8 signal channels
- Two analog comparators
- SPI™, I²C™, and AUSART communication protocol support
- Three timers and two Capture/Compare/PWM Modules

Development Tools

To help you reduce time to market, the PIC16F946 is supported by Microchip's standard, high-performance development systems, including:

- MPLAB® Integrated Development Environment (IDE)
- MPLAB ICD 2 In-Circuit Debugger
- MPLAB ICE 2000 In-Circuit Emulator
- PICDEM™ LCD Demo Board (part #DM163028)
- PICDEM LCD Daughter Board (part #MA160011)

In addition, Microchip created an online design center to aid in your development of LCD-related products: www.microchip.com/LCD.

Availability

The **PIC16F946** LCD microcontroller is available today for general sampling and volume production in a 64-pin TQFP package. For pricing or additional information, contact any Microchip sales representative or authorized Microchip distributor or visit Microchip's web site at www.microchip.com.

For more information visit: www.microchip.com/pic16F946

Visit the LCD Design Center to see the LCD Feature Matrix at www.microchip.com/LCD,

[RETURN TO FRONT PAGE](#)

High Resolution A/D Conversion with PIC® Microcontrollers

Introduction

There are several features on newer Flash-based PIC® microcontrollers that make the creation of a delta-sigma Analog-to-Digital Converter (ADC) very simple to implement. These features are: (1) the Timer1 gate input and (2) the internal comparator synchronized to the Timer1 clock source. Before discussing how these features make creating a delta-sigma ADC easy, let's review how such a converter works.

How a Delta-Sigma ADC Works

Figure 1 shows the circuit diagram for a typical comparator based delta-sigma ADC. Two resistors are used to create a reference voltage of $V_{DD}/2$ at the positive input of the comparator. The negative input of the comparator is tied to the analog input via a resistor. Another resistor of the same value connects the negative input to the output of the comparator via software. A capacitor, C1, connects the negative input of the comparator to ground.

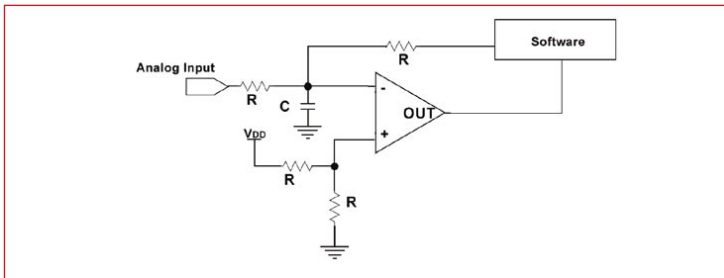

Figure 1: Delta-Sigma Converter Using a Standard Microcontroller

The output of the comparator is sampled at a constant frequency. When the comparator output is high, the pin driving the negative input of the comparator (CIN-) is driven high in the software. This causes the voltage at CIN- to increase until it is above $V_{DD}/2$. At this point, the comparator output becomes low and the pin driving CIN- is driven low in the software. Now the voltage at CIN- will fall until it is below $V_{DD}/2$. This cycle continues to repeat itself. During this process, two things are measured — the total number of samples and the number of samples that the comparator output is low by. The ratio of low samples to total samples gives the ADC result. A very high resolution is possible because the resolution is directly related to the number of times the output is sampled.

This method requires software to sample the comparator output and then mirror this output on the pin driving CIN-. A connection directly from the comparator output to CIN- is not possible because the pin can only change when the comparator output is sampled. In addition, software is used to count the total number of samples and the number of samples that are low. Though a PIC microcontroller is very capable of performing this task, special care must be taken when creating the software to ensure the comparator is sampled at a set time interval. Furthermore, the PIC microcontroller is limited in which tasks it is capable of performing while the conversion is taking place.

How a PIC® Microcontroller Simplifies the Conversion

Two features on newer Flash-based PIC microcontrollers allow this task to be accomplished with fewer processor resources and with greater speed. These features are the Timer1 gate input and the option to synchronize the comparator output changes to the Timer1 clock source.

The comparator can be configured to change only on the falling edge of the clock source for Timer1. This makes it possible to tie the comparator output directly to CIN- via a resistor because the output will only change with the Timer1 clock source. Software is no longer required to sample the comparator output and mirror it on the pin driving CIN-.

Synchronizing the comparator output with the Timer1 clock source ensures the comparator is sampled at constant intervals. The Timer1 gate function can be used to count the number of times that the comparator output is low. With the Timer1 gate functionality enabled, Timer1 is only incremented when the gate is active. (Note the Timer1 clock source continues to run regardless of the Timer1 gate input.) The Timer1 gate can be tied to either the output of the comparator or an external pin. The ability to gate Timer1 with the comparator output simplifies the delta-sigma ADC conversion. Figure 2 shows the circuit with Timer1 gated by the comparator output and the comparator synchronized to the Timer1 clock source.

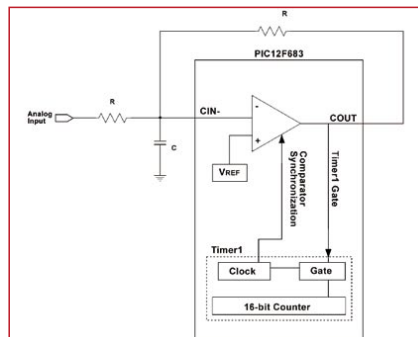

Figure 2: Delta-Sigma Converter Using the PIC12F683

Conclusion

The Timer1 gate and comparator synchronization features are found on many of Microchip's newer Flash-based PIC microcontrollers. These features allow a 16-bit delta-sigma ADC to be implemented entirely in hardware. Not only does this allow for faster conversion times, but the PIC microcontroller is free to process other tasks while the conversion takes place.

For more information on delta-sigma ADC theory and application, see Microchip's Application Note AN700, "Make a Delta-Sigma Converter Using a Microcontroller's Analog Comparator Module".

Authors: Reston A. Condit, Senior Applications Engineer, Security, Microcontroller & Technology Division, Microchip Technology Inc. Justin Milks, Applications Engineer, Security, Microcontroller & Technology Division Microchip Technology Inc.

[RETURN TO FRONT PAGE](#)

Sometimes Noise Can Be Good

By Bonnie C. Baker, Microchip Technology Inc.

When I started to write this article someone saw the title and asked, "You don't have any kids, do you?" Well, I did have the charge of children at one time in my life, but I think people forget two things through their lives: extreme pleasure and extreme pain. That's why we keep going back for more. This column is not about going back to painful experiences such as a noisy circuit. Rather, it is about the pleasure of tackling those difficult analog noise problems in the digital domain.

We have all sought the perfect conversion in our mixed-signal circuits where the converter produces a repeatable, accurate digital result every time. We use noise-reduction techniques such as selecting low-noise devices, a careful layout and analog filtering to remove undesirable signals. But, another way to approach noisy analog-to-digital conversion problems is to "design" noise into your signal instead of out. For instance, you can get 12-bit accuracy from a 12-bit converter if you are diligent about applying low-noise strategies to your circuit. As an alternative, you can allow a degree of white noise into the circuit and follow the conversion with a processor or controller digital filter. In this scenario, your circuit is capable of producing 14-, 15- or even 16-bit accuracy. If there is noise in your circuit, you can achieve better resolution at the output of a digital filter by using oversampling techniques.

For instance, if you use a simple rolling-average digital filter, you can calculate the number of bits (N) that you will add to your conversion resolution with this formula: #oversampled data = 2^{2N} . If you want to increase your resolution from 11 bits to 14 bits, you need to accumulate and average 64 samples. Time is the primary tradeoff for this increase in resolution. The rolling-average digital-filter algorithm accumulates several samples in order to calculate the

final result. The accumulation of these samples takes time. Finite Impulse Response (FIR) and Infinite Impulse Response (IIR) digital filters are also well suited for this task.

If you have the time, this sounds like a simple solution. However, there is one more issue to consider before you embrace this combination of analog with digital systems in your circuit. You must know the complexion of your ADC digital output over time. A histogram plot is an appropriate tool to use when examining your digital code over time. The histogram plot displays the number of occurrences of each code. For example, the histogram plot in Figure 1 shows 1024 repetitive data samples from a 12-bit ADC (sample rate = 20 ksps).

If you want to successfully increase the resolution of your converter, you need to ensure that the noise from the ADC is gaussian in nature. In a histogram plot, gaussian noise looks similar to a statistically normal distribution around a center code. The data in Figure 1 appears to have a bi-modal response. In addition, the output mean of this system should be 2236 instead of 2297. A digital filter will not "fix" this data. The noise in this system originates in an LED array. Poor layout and high currents through the array make the noise on the board intolerable.

If you use a digital filter at the output of your ADC, you are not relieved of the responsibility of knowing what kind of data you are producing. Digital filtering will improve the resolution of your analog-to-digital conversion, but only if you are confident that the noise response of your data is gaussian in nature.

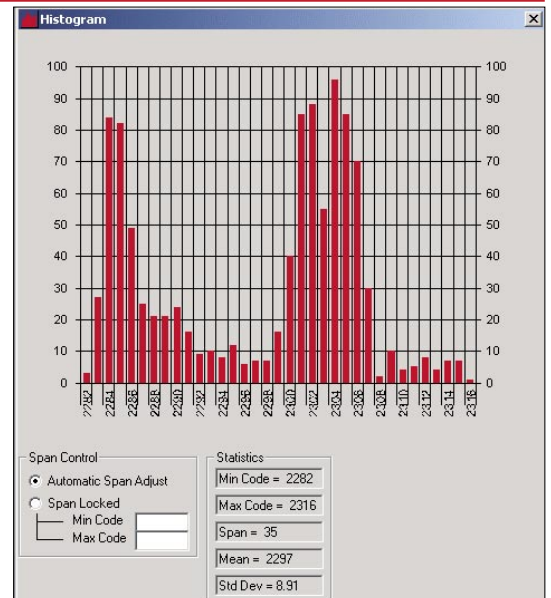

Figure 1: This histogram plot shows data from an ADC that is bimodal. It is difficult, if not impossible, to apply digital filtering to this data to recover a digital code that actually represents the input analog voltage accurately.

References

"Mixed-Signal and DSP Design Techniques", Walt Kester, Elsevier, 2003.

For more information visit: www.microchip.com/LowPower

Featured Product

ANALOG



The MCP3905/6 devices are energy metering ICs that supply average active power information via a pulse output with direct drive for mechanical counters. They also include a higher-frequency output that supplies instantaneous power information for calibration. The devices contain function blocks specific for IEC energy meter compliance, such as a no-load threshold and startup current.

The MCP3905/6 Energy Meter Reference Design Printed Circuit Board (PCB) is used as a reference design for single-phase, residential meters. The MCP3905/6 Energy Meter Reference Design Kit includes all necessary PCB circuits and layout tips for IEC62053 and prior 1036/61036/687 active-energy meter standards compliance. For more information regarding IEC compliance, refer to AN994, "IEC Compliant Active Energy Meter Design Using The MCP3905/6" (DS00994).

Learn more about these ICs in the December issue of **microSOLUTIONS!**

For more information visit: www.microchip.com/Meter

[RETURN TO FRONT PAGE](#)



Find out how Microchip has helped embedded control designers energize their applications with a better understanding of analog and digital power control and consumption. For more details, visit:

<http://techtrain.microchip.com/seminars/>

USA AND CANADA SEMINAR DATES AND LOCATIONS (INTRODUCTORY AND EXPERIENCED)

FREE!

Beginner
Introductory Embedded Control Solutions
(Morning Session)

Watch the evolution of a simple application into a more complex design with added functionality using PIC® microcontrollers, analog products and various easy-to-use development tools and starter kits. All attendees will receive a limited time offer for a discount on Microchip's development tools.

Register for this session if:

- You have not designed with PIC microcontrollers or Microchip's analog products
- You are interested in 8-bit embedded control
- You want to learn about Microchip's analog products

What you will learn:

- Overview of Microchip product families
- Overview of Microchip's hardware and software tools
- Where to find more information

Agenda:

- Overview of Microchip Technology's product families
- Basic Design Example: Simple low-power design with a 6-pin microcontroller and basic tools
- Taking design to the next level: Adding more intelligence with more advanced microcontrollers and stand-alone analog devices
- Improving the System Power Consumption
- Advanced Control: Adding advanced calculation and control in applications

Cost: FREE

[Details and Registration \(U.S. and Canada\)](#)

[Details and Registration \(Europe\)](#)

Experienced
Portable Power Management Solutions
(Afternoon Session)

This seminar addresses how battery energy is efficiently transferred to the system load and how energy is properly restored to rechargeable batteries. Power-management architecture advantages and disadvantages for recharging batteries is a primary focus with background theory followed by practical examples.

Register for this session if:

- You have attended the morning session
- OR
- You are currently using battery management applications and are looking for new solutions and feature sets
- You are thinking about incorporating battery charging designs into your applications or want more background in battery chemistries

What you will learn:

- Battery chemistry performance trade-offs
- Efficient energy removal techniques
- How to effectively restore energy to rechargeable batteries

Agenda:

- Battery Basics
- Efficiently Transferring Battery Energy to the System Load
- Systematic Approach to Designing a Charging System

Cost: \$99.00 USD - Includes lunch plus 2 development boards

[Details and Registration \(U.S. and Canada\)](#)

[Details and Registration \(Europe\)](#)

CITY	STATE	DATE
Dorval	Canada	18 Oct 2005
Mississauga	Canada	20 Oct 2005
West Conshohocken	PA	25 Oct 2005
Minnnetonka	MN	26 Oct 2005
Fishers	IN	26 Oct 2005
Miamisburg	OH	27 Oct 2005
Cromwell	CT	27 Oct 2005
East Hanover	NJ	01 Nov 2005
Waukesha	WI	01 Nov 2005
San Jose	CA	02 Nov 2005
Wheeling	IL	03 Nov 2005
Chelmsford	MA	03 Nov 2005
Baltimore	MD	04 Nov 2005
Cranberry Township	PA	04 Nov 2005
Duluth	GA	08 Nov 2005
Grand Rapids	MI	08 Nov 2005
Ann Arbor	MI	09 Nov 2005
Agoura Hills	CA	09 Nov 2005
Deerfield Beach	FL	10 Nov 2005
Overland Park	KS	10 Nov 2005
Richardson	TX	10 Nov 2005
San Diego	CA	15 Nov 2005
Houston	TX	15 Nov 2005
Rochester	NY	16 Nov 2005
Austin	TX	16 Nov 2005
Newport Beach	CA	17 Nov 2005
Salt Lake City	UT	30 Nov 2005
Burnaby	Canada	07 Dec 2005
Tigard	OR	08 Dec 2005

See How Easy it is to Start Designing with Baseline and Mid-Range Microcontrollers



Can you spare 20 minutes to see for yourself how easy it is to start designing with Baseline and Mid-Range microcontrollers?

Come to www.microchip.com/StartNowContest today and enter Microchip's START NOW Design Contest. Use your imagination, generate innovative uses for our PIC® microcontrollers, share your knowledge with fellow designers (we post the winning entries every month), enter to win some prizes (20 prizes awarded every month) and have some fun. Creativity counts – design ideas should take no more than about 20 minutes of your time to write up and draw.

Want to know more? Read on!

Your Idea

- Must use one or more of the following new PIC microcontrollers and can also use several of our stand-alone analog products for extra bonus points:
PIC10F220 (6-pin)
PIC10F222 (6-pin)
PIC12F510 (8-pin)
PIC16F506 (14-pin)
- Must be technically feasible and appropriate for the "Project Theme" for the month in which it is entered
- Must have appropriate electrical connections and draw current
- Should take no more than 20 minutes of your time to write up and draw the circuit

Monthly Prizes

- 3 First Place Prizes – PICkit™ 2 Starter Kit with protoboard and cables
- 7 Second Place Prizes – special "START NOW" sample kits
- 10 Runners Up – a Microchip polo shirt
- **BONUS PRIZE:** If you use one or more Microchip analog products in your design, your entry will be included in an additional monthly drawing for an analog PICtail™ daughter board

Grand Prize

A grand prize winner, selected by random drawing from among all the qualified contest entries between August 1 and December 31, 2005, will receive a 6-drawer tool chest filled with a selection of Microchip development tools and product samples.

The imagination and creativity exhibited by the engineers submitting entries in the September "Remote Applications" category made for some very difficult judging in the second month of the contest. The following three entries earned their designers a PICkit™ 2 Starter Kit as first place winners in September. To learn more about their designs visit the Design Contest page at: <http://techtrain.microchip.com/StartNow/>, and click on "Examples".

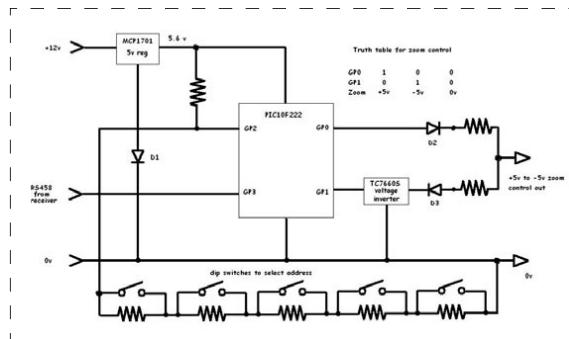

You really CAN take the P&T out of PTZ: submitted by Gordon Zerf (United Kingdom). This cost-effective remote control provides pan and tilt features to auto focus CCTV cameras using Microchip's PIC10F222, MCP1701 and TC7660S devices.

Click on images to enlarge.

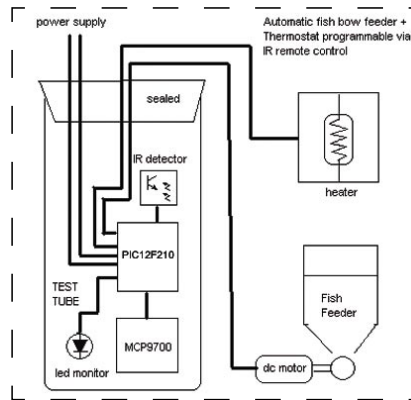

Automatic Fish-Bowl Feeder and Thermostat: Renato Kodaira's (Brazil) design uses a PIC12F210 and an MCP9700 to control the fish feeder and a electrical heater, with settings programmable via IR.

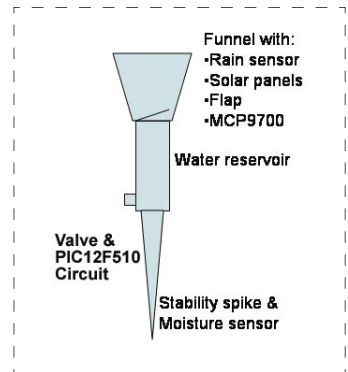

The Rose Protector: submitted by Maarten Hoffman (USA). This device protects roses by providing adequate water based on moisture and temperature using Microchip's PIC12F510 and MCP9700 devices.

[RETURN TO FRONT PAGE](#)

Tips 'n Tricks - LCD PICmicro® Microcontrollers

Using an LCD PICmicro® microcontroller for any embedded application can provide the benefits of system control and human interface via an LCD. Design practices for LCD applications can be further enhanced through the implementation of these suggested Tips 'n Tricks. These tips describe basic circuits and software building blocks commonly used for driving LCD displays. Additional tips and tricks can be found at: www.microchip.com.

TIP 1. In-Circuit Debug (ICD)

There are two potential issues with using the MPLAB® ICD to debug LCD applications. First, the LCD controller can Freeze while the device is Halted. Second, the ICD pins are shared with segments on the PIC16F917/916/914/913 MCUs. When debugging, the device is Halted at breakpoints and by the user pressing the pause button. If MPLAB ICD is configured to Halt the peripherals with the device, the LCD controller will Halt and apply DC voltages to the LCD glass. Over time, these DC levels can cause damage to the glass; however, for most debugging situations, this will not be a consideration. The PIC18F LCD MCUs have a feature that allows the LCD module to continue operating while the device has been Halted during debugging. This is useful for checking the image of the display while the device is Halted and for preventing glass damage if the device will be Halted for a long period of time. The PIC16F917/916/914/913 multiplex the ICSP™ and ICD pins onto pins shared with LCD segments 6 and 7. If an LCD is attached to these pins, the device can be debugged with MPLAB ICD; however, all the segments driven by those two pins will flicker and be uncontrolled. As soon as debugging is finished and the device is programmed with Debug mode disabled, these segments will be controlled correctly.

TIP 2. LCD in Sleep Mode

If you have a power-sensitive application that must display data continuously, the LCD PIC® microcontroller can be put to Sleep while the LCD driver module continues to drive the display.

To operate the LCD in Sleep, only two steps are required. First, a time source other than the main oscillator must be selected as the LCD clock source, because during Sleep, the main oscillator is Halted. **Table 2-1** shows options for the various LCD PIC microcontrollers.

Part	LCD Clock Source	Use in Sleep?
PIC16C925/926	FOSC/256	No
	T1OSC	Yes
	Internal RC Oscillator	Yes
PIC16F917/916/914/913	FOSC/8192	No
	T1OSC/32	Yes
	LFINTOSC/32	Yes
PIC18F8490	(FOSC/4)/8192	No
	T1OSC	Yes
	INTRC/32	Yes

Table 2-1: Options for LCD in Sleep mode

Second, the Sleep Enable bit (SLPEN) must be cleared. The LCD will then continue to display data while the part is in Sleep. It's that easy!

When should you select the internal RC oscillator (or LFINTOSC) over the Timer1 oscillator? It depends on whether your application is time-sensitive enough to require the accuracy of a crystal on the Timer1 oscillator or not. If you have a timekeeping application, then you will probably have a 32 kHz crystal oscillator connected to Timer1. Since Timer1 continues to operate during Sleep, there is no penalty in using Timer1 as the LCD clock source. If you don't need to use an external oscillator on Timer1, then the internal RC oscillator (INTRC or LFINTOSC) is more than sufficient to use as the clock source for the LCD and it requires no external components.

TIP 3. Blinking LCD

Information can be displayed in more than one way with an LCD panel. For example, how can the user's attention be drawn to a particular portion of the LCD panel? One way that does not require any additional segments is to create a blinking effect.

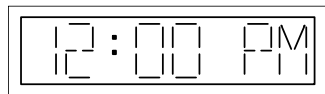

Figure 3-1: Common Clock Application

Look at a common clock application (**Figure 3-1**). The : between the hours and minutes is commonly made to blink once a second ("on" for half a second, and "off" for half a second). This shows that the clock is counting in absence of the ticking sound or second hand that accompanies the usual analog face clock. It serves an important purpose of letting the user know that the clock is operating.

If there is a power outage, then it is common for the entire clock display to blink. This gives the user of the clock an immediate indication that the clock is no longer showing the correct time. When the user sets the time, then blinking is commonly used to show that a new mode has been entered, such as blinking the hours to identify that the hours are being set, or blinking the minutes to show that the minutes are being set. In a simple clock, blinking is used for several different purposes. Without blinking effects, the common digital clock would not be nearly as user friendly.

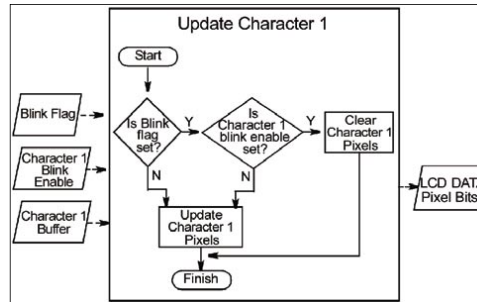

Figure 3-2: Updating Display Chart Flowchart

Fortunately, blinking is quite easy to implement. There are many ways to implement a blinking effect in software. Any regular event can be used to update a blink period counter. A blink flag can be toggled each time the blink period elapses. Each character or display element that you want to blink can be assigned a corresponding blink enable flag. The flowchart for updating the display would look as pictured in **Figure 3-2**.

[RETURN TO FRONT PAGE](#)

Tips 'n Tricks - LCD PICmicro® Microcontrollers

TIP 4. 4 x 4 Keypad Interface that Conserves Pins for LCD Segment Drivers

A typical digital interface to a 4 x 4 keypad uses 8 digital I/O pins. But using eight pins as digital I/Os can take away from the number of segment driver pins available to interface to a LCD. By using 2 digital I/O pins and 2 analog input pins, it is possible to add a 4 x 4 keypad to the PIC® microcontroller without sacrificing any of its LCD segment driver pins. The schematic for keypad hook-up is shown in **Figure 4-1**. This example uses the PIC18F8490, but the technique could be used on any of the LCD PIC microcontrollers.

The two digital I/O pins that are used are RB0 and RB5, but any two digital I/O pins could work. The two analog pins used are AN0 and AN1.

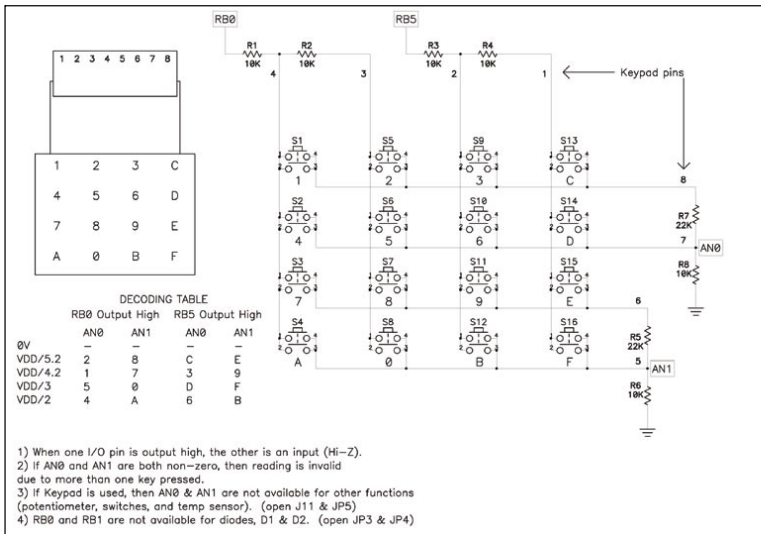

Figure 4-1: Keypad Hook-up Schematic

To read the keypad, follow the steps below:

1. First, make RB0 an output high and RB5 an input (to present a high impedance).
2. Perform two successive A/D conversions; first on AN0, then on AN1.
3. Save the conversion results to their respective variables; for example, RB0_AN0_Result and RB0_AN1_Result.
4. Next, make RB5 an output high and RB0 an input (to present a high impedance).

5. Perform two successive A/D conversions; first on AN0, then on AN1.
6. Save the conversion results to their respective variables; for example, RB5_AN0_Result and RB5_AN1_Result.
7. There are now 4 variables that represent a key press in each quadrant of the 4 x 4 keypad:
 - RB0_AN0_Result . denotes key press of 1, 2, 4 or 5
 - RB0_AN1_Result . denotes key press of 7, 8, A or 0
 - RB5_AN0_Result . denotes key press of 3, C, 6 or D
 - RB5_AN1_Result . denotes key press of 9, E, B or F
8. Finally, check each value against the matching column of **Table 4-1**. If it is within ±10% of a value, then it can be taken to indicate that the corresponding key has been pressed.
9. This loop should be repeated about once every 20 ms or so. Don't forget a debounce outline. For example, require the above steps (with 20 ms delay between) to return the same key value twice in a row for that key to be considered pressed. Also, require a no key press to be returned at least twice before looking for the next key press.

When keys within the same quadrant are pressed simultaneously, voltages other than the four valid levels shown in the table may be generated. These levels can either be ignored, or if you want to use simultaneous key presses to enable certain functions, you can add decoding for those levels as well.

Value ±10%	RB0_AN0	RB0_AN1	RB5_AN0	RB5_AN1
<VDD/10	—	—	—	—
VDD/5.2	2	8	C	E
VDD/4.2	1	7	3	9
VDD/3	5	0	D	F
VDD/2	4	A	6	B

Table 4-1: Keypad Values

Have you missed an issue of microSolutions?
 Visit the microSolutions archive page today at <http://www.microchip.com/microSolutions/>.

[RETURN TO FRONT PAGE](#)

Archived WebSeminars

For more information visit: www.microchip.com/webseminars

Seminar Title	Category	Date	Duration
Introduction to Serial EEPROMs	Products	Sep 2005	20 min.
Microchip's ENC28J60: the World's Smallest Ethernet Controller	Connectivity	July 2005	20 min.
dsPIC30F: General Purpose Timers	Products	April 2005	30 min.
Serial Communications: Using the dsPIC30F I ² C™ Module	Connectivity	April 2005	30 min.
Serial Communications: Using the dsPIC30F CAN Module	Connectivity	April 2005	30 min.
dsPIC® DSC: SPI™ Communication Module	Products	March 2005	20 min.
dsPIC® DSC: UART Module	Products	March 2005	20 min.
dsPIC30F: Quadrature Encoder Interface Module	Motor Control	March 2005	20 min.
dsPIC30F: Motor Control PWM Module	Motor Control	March 2005	20 min.
Introduction to Mechatronics and the Mechatronics Design Center	Applications	Feb 2005	20 min.
Do I Filter Before, After, or Never?	Analog	Jan 2005	20 min.
Designing Intelligent Power Supplies	Applications	Dec 2004	30 min.
Introduction to dsPIC30F Architecture (Part 1)	Products	Dec 2004	20 min.
Introduction to dsPIC30F Architecture (Part 2)	Products	Dec 2004	20 min.
The LCD PIC® Microcontrollers, PIC18F8490/6490, with 16 Kbytes of Flash in 64- and 80-pin Packages	Products	Nov 2004	20 min.
Thermistor Application for the New MCP6S9X PGA	Applications	Nov 2004	20 min.
Introduction to the dsPIC® DSC	Products	Nov 2004	20 min.
64 Kbyte Flash Microcontrollers in 28- and 40-pin packages: PIC18F4620 and PIC18F2620	Products	Oct 2004	20 min.
Introduction to the Signal Analysis PICtail™ Daughter Board	Development Tools	Oct 2004	30 min.
Basic dsPIC® DSC Development Tools	Development Tools	Oct 2004	25 min.
Introduction to MPLAB® SIM Software Simulator	Development Tools	Sep 2004	25 min.
Get Started with the 64-/80-pin TQFP Demo Board	Development Tools	Sep 2004	20 min.
Tips and Tricks Using MPLAB® IDE v6.61	Development Tools	Sep 2004	30 min.
Introduction to the PIC18F High Pin Count and High Density Family of Devices	Development Tools	Sep 2004	20 min.
Introduction to the MPLAB® Visual Device Initializer (VDI)	Development Tools	Aug 2004	30 min.
Selecting the Ideal Temperature Sensor	Analog	Aug 2004	30 min.
PIC10F Development Tools: Small Tools for Small Parts	Development Tools	Aug 2004	30 min.
An Introduction to the Controller Area Network (CAN)	Interface	Jun 2004	30 min.
Control the World with the World's Smallest Microcontroller (PIC10F)	Products	Jun 2004	30 min.
Predict the Repeatability of Your ADC to the Bit	Analog	May 2004	20 min.
What Does "Rail-to-Rail" Operation Really Mean?	Analog	Apr 2004	20 min.
Introduction to MPLAB® IDE	Development Tools	Mar 2004	25 min.
Lithium-Ion Battery Charging: Techniques and Trade-offs	Analog	Mar 2004	20 min.
Techniques that Reduce System Noise in ADC Circuits	Analog	Feb 2004	20 min.
Introduction to Microchip's Development Tools	Development Tools	Feb 2004	25 min.
Wireless Communication Using the IrDA® Standard Protocol	Applications	Jan 2004	20 min.
Driving Lumileds LEDs with Microchip PIC® Microcontrollers	Applications	Jan 2004	60 min.

[RETURN TO FRONT PAGE](#)

WHAT'S *New* IN MICROCHIP LITERATURE?Click on a **Document Title** to view the document.

Type of Document	Title of Document	DS#	Print/Web
Application Notes	AN1004. Using the MPLAB® C18 Compiler to Interface Microwire Serial EEPROMs to PIC18 Devices	01004A	Web
	AN909. Interfacing SPI™ Serial EEPROMs to PIC16 Devices	00909B	Web
	AN996. Designing a Digital Compass Using the PIC18F2520	00996A	Web
	AN257. DTMF Detection Using PIC18 MCUs	00257A	Web
	AN1003. USB Mass Storage Device Using a PIC® MCU	01003A	Web
	AN1001. Improving IC Temperature Sensor Accuracy with a PICmicro® MCU	01001A	Web
Code Example	Driving a BLDC with Sinusoidal Voltages Using dsPIC30F	92003A	Web
Data Sheets	PIC10F220/222 Data Sheet	41270A	Web
	24XX515 512K I²C™ CMOS Serial EEPROM	21673F	Web
	24XX1025 1024K I²C™ CMOS Serial EEPROM	21941B	Web
	25AA256/25LC256 Data Sheet	21822E	Web
	24AA64/24LC64 64K I²C™ Serial EEPROM	21189K	Web
	24AA128/24LC128/24FC128 128K I²C™ CMOS Serial EEPROM	21191N	Web
	24AA256/24LC256/24FC256 256K I²C™ CMOS Serial EEPROM	21203N	Web
	24AA32A/24LC32A 32K I²C™ Serial EEPROM	21713F	Web
	24AA512/24LC512/24FC512 512K I²C™ CMOS Serial EEPROM	21754G	Web
	PIC10F22XX Data Sheet	41270A	Web
	PIC18F87J10 Family Data Sheet	39663B	Web
	MCP3905 - Energy Metering IC with Active Real Power Pulse Output	21948B	Web
	MCP1612 - Single 1A 1.4 MHz Synchronous Buck Regulator	21921B	Web
MCP73861/2/3/4 - Advanced Single or Dual Cell, Fully Integrated Li-Ion/Li-Polymer Charge Management Controllers	21893C	Web	
Design Guides	Fan Control Function Pack Design Guide	21835C	Web/Printed
	Interface Products Design Guide	21883B	Web/Printed
Erratas	dsPIC30F6011A/6012A/6013A/6014A Rev. A2 Silicon Errata	80242B	Web
	PIC16F685/687/689/690 Data Sheet Errata	80243B	Web
	PIC18F87J10 Family Rev. A2 Silicon Errata	80246A	Web
	PIC16F87XA Rev. B6 Silicon Errata	80240A	Web

[RETURN TO FRONT PAGE](#)

WHAT'S *New* IN MICROCHIP LITERATURE?

Click on a **Document Title** to view the document.

Erratas (continued)	PIC18F1220/1330 Rev. B4 Silicon/Data Sheet Errata	80175E	Web
	PIC18F1220/1330 Rev. B1 Silicon/Data Sheet Errata	80160E	Web
	PIC16F72 Data Sheet Errata	80155C	Web
	PIC18F1220/1320 Rev. D0 Silicon/Data Sheet Errata	80244A	Web
	PIC18FXX2 Rev. C1 Silicon/Data Sheet Errata	80245A	Web
	PIC18FXX2 Rev. C0 Silicon/Data Sheet Errata	80173C	Web
	PIC18F2X1X/4X1X Data Sheet Errata	80227B	Web
	PIC18F2525/2620/4525/4620 Data Sheet Errata	80222B	Web
Product Briefs	PIC12F615/12HV615/PIC16F616/HV616	41272A	Web
	MCP1702 2uA Low Dropout Positive Voltage Regulator	21983A	Web
	TC4423A/24A/25A - 3A Dual High-Speed Power MOSFET Drivers	21979A	Web
Programming Specs.	PIC12F629/675/PIC16F630/676 Memory Programming	41191D	Web
	PIC16F785/PS200 Programming	41237B	Web
	PIC12F6XX/16F6XX Memory Programming	41204F	Web
	PIC18F2XX0/2X21/2XX5/4XX0/4X21/4XX5 Flash Programming Specification	39622F	Web
	PIC18F220/X320 Flash Microcontroller Programming Specification	39592C	Web
Reference Manual	dsPIC30F Family Reference Manual	70046D	Web
Technical Briefs	Quadrature Encoder Simulator Using the PIC10F2XX	91091A	Web
	MCP2030 3-Channel Analog Front-End Device Overview	91090A	Web
User Guides	MPASM™ Assembler, MPLINK™ Object Linker, MPLIB™ Object Librarian User's Guide	33014J	Web
	MPLAB® IDE Quick Start Guide	51281E	Web
	MCP2515 Stand-Alone CAN Controller PICtail™ Demo Board User's Guide	51572A	Web
	MCP3905/6 Evaluation Board User's Guide	51567A	Web
	MCP212X Developer's Daughter Board User's Guide	51571A	Web

The Microchip name and logo, the Microchip logo, Accuron, dsPIC, KEELo, microID, MPLAB, PIC, PICmicro, PICSTART, PRO MATE, PowerSmart, rPIC, and SmartShunt are registered trademarks of Microchip Technology Incorporated in the U.S.A. and other countries.

Amplab, FilterLab, Migratable Memory, MXDEV, MXLAB, PICMASTER, SEEVAL, SmartSensor and The Embedded Control Solutions Company are registered trademarks of Microchip Technology Incorporated in the U.S.A.

Analog-for-the-Digital Age, Application Maestro, dsPICDEM, dsPICDEM.net, dsPICworks, ECAN, ECONOMONITOR, FanSense, FlexROM, fuzzyLAB, In-Circuit Serial Programming, ICSP, ICEPIC, Linear Active Thermistor, MPASM, MPLIB, MPLINK, MPSIM, PICKIT, PICDEM, PICDEM.net, PICLAB, PICtail, PowerCal, PowerInfo, PowerMate, PowerTool, rLAB, rPICDEM, Select Mode, Smart Serial, SmartTel, Total Endurance and WiperLock are trademarks of Microchip Technology Incorporated in the U.S.A. and other countries.

SQTP is a service mark of Microchip Technology Incorporated in the U.S.A.

All other trademarks mentioned herein are property of their respective companies.

© 2005, Microchip Technology Incorporated. Printed 11/2005.

[RETURN TO FRONT PAGE](#)

web site HIGHLIGHTS

Did you know...

We have a new section on Op Amps to help you get started quickly!!! The Microchip Op Amp Discovery Card helps to identify op amps by various factors. Visit www.microchip.com/web/DiscoverOpAmps.

The screenshot shows the Microchip website interface with a navigation menu and a search bar. The main content area displays the 'MICROCHIP OP AMP DISCOVERY CARD' table, which lists various op amp models categorized by performance characteristics like Low Cost, Low Quiescent Current, Low Noise, Low Supply Voltage, Low Offset Voltage, and Small Package. The table is organized into rows and columns, with each cell containing a list of part numbers.

	Low Cost	Low Quiescent Current	Low Noise	Low Supply Voltage	Low Offset Voltage	Small Package
Low Cost	MCP6001 MCP6002 MCP6004	MCP6231 MCP6232 MCP6234 MCP6241 MCP6242 MCP6244	MCP6291 MCP6292 MCP6293 MCP6294	MCP6001 MCP6002 MCP6004	MCP606 MCP607 MCP608 MCP609 MCP616 MCP617 MCP618 MCP619 MCP6021 MCP6022 MCP6023 MCP6024	MCP6001 SOT-23
High GBWP	MCP6291 MCP6292 MCP6293 MCP6294 10 MHz	MCP6281 MCP6282 MCP6283 MCP6284 5 MHz	MCP6291 MCP6292 MCP6293 MCP6294 MCP6021 MCP6022 MCP6023 MCP6024 10 MHz	MCP6291 MCP6292 MCP6293 MCP6294 MCP6021 MCP6022 MCP6023 MCP6024 10 MHz	MCP6021 MCP6022 MCP6023 MCP6024 10 MHz	MCP6291 MCP6021 ⁽¹⁾ SOT-23
Low Offset Voltage	MCP606 MCP607	MCP606 MCP607	MCP6021 MCP6022 MCP607	MCP606 MCP607	TC913	MCP606 MCP6021 ⁽¹⁾

<http://buy.MICROCHIP.com>
ONLINE CATALOG

One-stop shopping for MCUs, digital signal controllers, analog and serial EEPROMs.

Attention customers in Italy, Spain, Portugal, Finland, Austria, Greece, Sweden, Denmark, Poland, Czech Republic, Latvia, Lithuania, Cypress, Malta, Estonia, Hungary, Slovak Republic and Slovenia. Microchip has negotiated special reduced shipping rates to your countries. Effectively immediately, shipping costs to these countries has been reduced by 50%!

For more details, visit: <http://buy.microchip.com>

New Utility Metering Design Center

Implementing an electronic meter does not have to be a complex endeavor. Microchip makes it easy for you.

Visit www.microchip.com/Meter for more information.

Utility Metering Design Center

Click on any of the four meter types below for complete technical information.



[Gas Meter](#)



[Water Meter](#)



[Energy Meter](#)



[Heat Meter](#)



JOBS AT MICROCHIP

If you are interested in joining the Microchip team, go to www.microchip.com/Careers

[RETURN TO FRONT PAGE](#)