ATADAPCAN01 - STK501 CAN Extension

The ATADAPCAN01 - STK501 CAN add-on is an extension to the STK500 and STK501 development boards from Atmel Corporation, adding support for the AVR AT90CAN128 device in a single development environment.

The AVR AT90CAN128 includes a built-in Controller Area Network (CAN) controller with all the features required to implement the CAN serial communication protocol in accordance with the "BOSCH GmbH" CAN specification.

The add-on board provides CAN transceivers, termination options and other features necessary to seamlessly connect the STK500 development environment to a CAN bus for application development and debugging.

Requirements

- STK500 starter kit, serial cable and power supply
- STK501 topmodule to STK500
- AVR AT90CAN128 in 64-pin TQFP package



**CAN
Microcontrollers**

**Quick Start
Guide**

Rev. 4330B-CAN-03/04



Connections to STK500 / STK501

The ATADAPCAN01 module is intended for use with the STK500 and STK501 starter kits. The STK501 holds the 64-pin TQFP ZIF socket for the AT90CAN128 part, and is a top-module board for the AVR starter-kit STK500. The ATADAPCAN01 requires connections to the CANTx and CANRx signals on the AVR device, as well as Vcc and GND connections. The ATADAPCAN01 board can be connected to the starter-kits in one of three possible ways:

- Individual signal wiring to PORTD. Using three 2-wire cables provided with the STK500 kit, make the following connections:
 - STK500 PD5 (pin6) to ATADAPCAN01 PORTD pin 6 (CANTx)
 - STK500 PD6 (pin7) to ATADAPCAN01 PORTD pin 7 (CANRx)
 - STK500 GND & VTG to ATADAPCAN01 PORTD pins 9 & 10
- Flat-cable connection to PORTD. Using a 10-wire flat-cable provided with the STK500 kit, connect the PORTD header of the STK500 to the PORTD header of the ATADAPCAN01, as shown in figure 1. Care should be taken to use the correct pin orientation.

Figure 1. Connecting to the STK500 through a 10-wire flat-cable

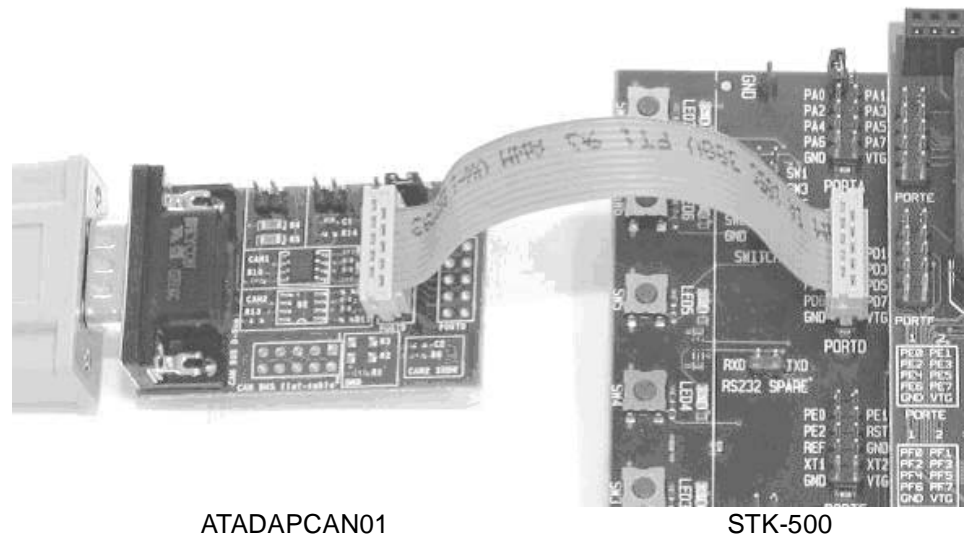

Direct mounting onto PORTD. A second PORTD header is routed (but not mounted) on the ATADAPCAN01 (J8). By attaching a matching 10 pin socket to the underside of the board, it can be mounted directly onto the STK500 PORTD header. The top-side PORTD header on the ATADAPCAN01 board can then be used to access other PORTD pins.

CAN Bus Interface

Several options are available to physically connect the ATADAPCAN01 to a CAN bus.

BUS Connectors

The D-SUB-9 MALE connector is the primary connection point to a CAN bus. Alternatively, the 10-pin header labelled "CAN BUS flat-cable" can be used, or both connectors can be used if the CAN bus topology requires it. Both connectors are wired according to CiA Draft Standard 102 version 2.0 as shown in table 1.

Table 1. CAN Bus Connector Wiring

Signal Description	D-SUB-9 pin	Flat-cable Pin
Reserved	1	1
CAN_L	2	3
CAN_GND	3	5
Reserved	4	7
CAN_SHLD*	5 ⁽¹⁾	g ⁽¹⁾
CAN_GND	6	2
CAN_H	7	4
Reserved	8	6
CAN_V+	9	8
(not used)		10

Note: 1. CAN_SHLD pins are not connected together internally

CAN BUS Grounding and Shielding

The "CAN_SHLD" signal in each of the two CAN bus connectors can be optionally connected to ground by mounting 0 ohm or small value resistors in positions R2 (for D-SUB-9) and R3 (for flat-cable). The landing pads of both R2 and R3 are 1206 standard size.

By default, the "CAN_GND" signals in both connectors are wired to the STK500 ground through 0 ohm resistor R1. Removing R1 will isolate the "CAN_GND" ground signals on the CAN bus from the STK500 / ATADAPCAN01 ground.

CAN BUS Termination

To function correctly, a CAN bus requires 120 ohm termination on both ends. The ATADAPCAN01 can become a terminated node on the CAN bus simply by setting the jumper labelled "TERM". This terminates the CAN bus with two series-connected 62 ohm resistors. Setting the jumper labelled "SPLIT" connects the centre-tap between these two resistors to ground through 10nF capacitor C1. This reduces common-mode noise on the bus line. This centre tap can also be stabilised as described later in the "Split voltage" section (if supported by the CAN transceiver mounted in "CAN1").

CAN Transceiver Options

The ATADAPCAN01 board has two CAN transceiver footprints. This is to facilitate easy evaluation of alternate CAN devices as well as to provide access to various extra features of some of these parts. Refer to the schematic diagram in Figure 2 (below) while considering these options.

Both "CAN1" and "CAN2" footprints use standard CAN device pinouts for pins 1, 2, 3, 4, 6 and 7. By default, "CAN1" is mounted on the board (Atmel ATA6660). To use a device in "CAN2", solder the device to the board, and remove the 0 ohm 'resistors' labelled R8, R9 R10 from the "CAN1" section, and mount them into the "CAN2" section in positions R11, R12, R13. Although it is acceptable that idle CAN transceivers remain attached to the CAN bus, only one CAN device should be connected to the AVR device at any time.

Figure 2. Component Placement

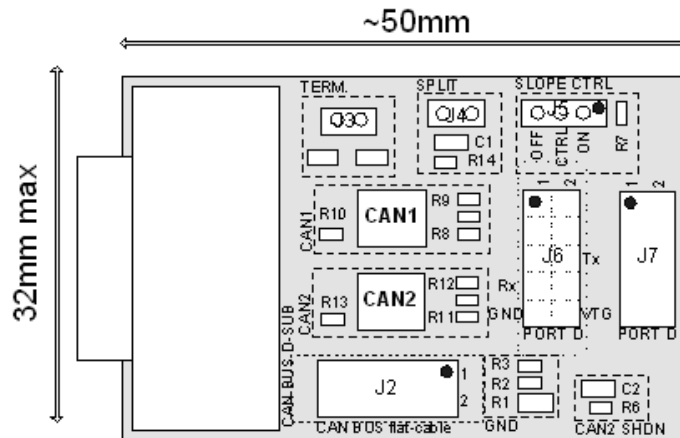

Utilising CAN-Transceiver Extra-features

Many CAN transceiver devices available have various extra functions accessible through pins 5 and 8. The ATADAPCAN01 allows you to take advantage of some of these features. Pin 8 on both "CAN1" and "CAN2" footprints are connected centre pin of the "SLOPE CTRL" connector. Pin 5 of "CAN1" is connected to the centre-tap of the termination network, and pin 5 of "CAN2" is connected to R6 and C2 as shown in Figure 2.

Slope Control (pin 8, "CAN1" and "CAN2")

CAN transceivers supporting slope or slew-rate control allow a resistor to be connected between the RS pin (pin 8) and ground to limit the slope of the bus-driving signal. This reduced EMI emissions while restricting the maximum transmission rate. Pin 8 on both "CAN1" and "CAN2" devices are connected to the centre pin of the "SLOPE CTRL" jumper. Setting the jumper to the ON position, connects the centre pin to ground through resistor R7, while setting it to the OFF position connects the centre pin directly to ground (for no slope control, or high-speed mode). Refer to the CAN transceiver device documentation for information on selecting the value of R7 (24k by default).

Standby Function (pin 8, "CAN1" and "CAN2")

On some CAN transceivers, pin 8 can be driven by a logic level to switch the transceiver into standby mode. The centre pin of the "SLOPE CTRL" header (with the jumper removed) can be connected to an I/O pin on the AVR device for this purpose. Your AVR code should drive this signal as specified in the CAN transceiver documentation.

Shutdown Function (pin 5, "CAN2")

Some CAN transceivers have a SHUTDOWN function which is configured by an R-C connection on pin 5. Pin 5 of the "CAN2" footprint is connected to resistor R6 to Vcc and capacitor C2 to ground, as shown in the schematic diagram. By default R6 is a 0 ohm connection to Vcc and C2 is not mounted. Both parts are 0603 size. Consult the CAN transceiver documentation for further information.

Split Voltage (pin 5, "CAN1")

The centre-point of the CAN bus termination (if enabled) can be stabilised by connecting it to pin 5 of certain CAN transceivers. If the CAN transceiver supports this feature, a 0 ohm 0603 resistor can be mounted in R14, with the "SPLIT" and "TERM" jumpers set accordingly (see Section "CAN bus termination").

Figure 3. Schematic Layout

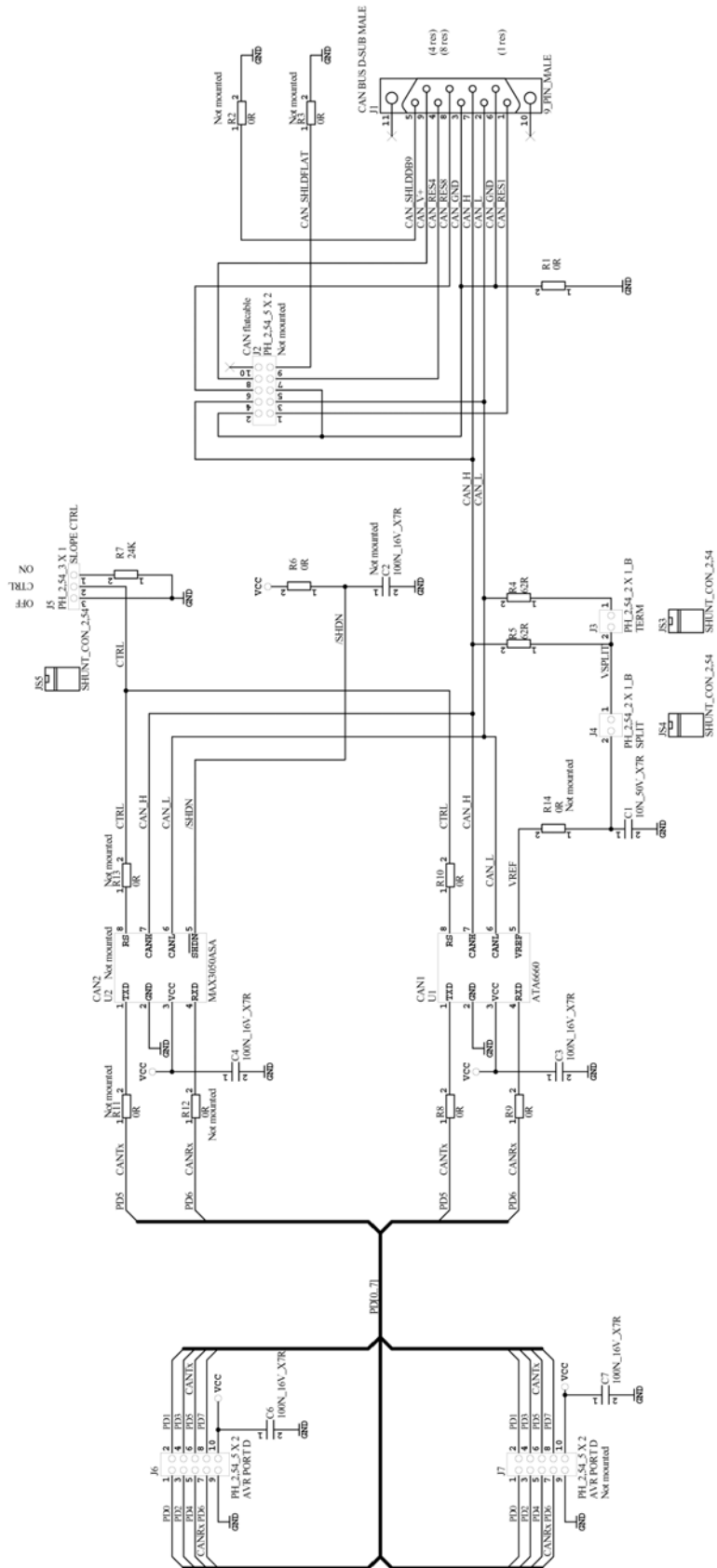



Atmel Headquarters

Corporate Headquarters

2325 Orchard Parkway
San Jose, CA 95131
TEL 1(408) 441-0311
FAX 1(408) 487-2600

Europe

Atmel Sarl
Route des Arsenaux 41
Case Postale 80
CH-1705 Fribourg
Switzerland
TEL (41) 26-426-5555
FAX (41) 26-426-5500

Asia

Room 1219
Chinachem Golden Plaza
77 Mody Road Tsimhatsui
East Kowloon
Hong Kong
TEL (852) 2721-9778
FAX (852) 2722-1369

Japan

9F, Tonetsu Shinkawa Bldg.
1-24-8 Shinkawa
Chuo-ku, Tokyo 104-0033
Japan
TEL (81) 3-3523-3551
FAX (81) 3-3523-7581

Atmel Operations

Memory

2325 Orchard Parkway
San Jose, CA 95131
TEL 1(408) 441-0311
FAX 1(408) 436-4314

Microcontrollers

2325 Orchard Parkway
San Jose, CA 95131
TEL 1(408) 441-0311
FAX 1(408) 436-4314

La Chantrerie
BP 70602
44306 Nantes Cedex 3, France
TEL (33) 2-40-18-18-18
FAX (33) 2-40-18-19-60

ASIC/ASSP/Smart Cards

Zone Industrielle
13106 Rousset Cedex, France
TEL (33) 4-42-53-60-00
FAX (33) 4-42-53-60-01

1150 East Cheyenne Mtn. Blvd.
Colorado Springs, CO 80906
TEL 1(719) 576-3300
FAX 1(719) 540-1759

Scottish Enterprise Technology Park
Maxwell Building
East Kilbride G75 0QR, Scotland
TEL (44) 1355-803-000
FAX (44) 1355-242-743

RF/Automotive

Theresienstrasse 2
Postfach 3535
74025 Heilbronn, Germany
TEL (49) 71-31-67-0
FAX (49) 71-31-67-2340

1150 East Cheyenne Mtn. Blvd.
Colorado Springs, CO 80906
TEL 1(719) 576-3300
FAX 1(719) 540-1759

Biometrics/Imaging/Hi-Rel MPU/ High Speed Converters/RF Data- com

Avenue de Rochepleine
BP 123
38521 Saint-Egreve Cedex, France
TEL (33) 4-76-58-30-00
FAX (33) 4-76-58-34-80

e-mail

literature@atmel.com

Web Site

<http://www.atmel.com>

Disclaimer: Atmel Corporation makes no warranty for the use of its products, other than those expressly contained in the Company's standard warranty which is detailed in Atmel's Terms and Conditions located on the Company's web site. The Company assumes no responsibility for any errors which may appear in this document, reserves the right to change devices or specifications detailed herein at any time without notice, and does not make any commitment to update the information contained herein. No licenses to patents or other intellectual property of Atmel are granted by the Company in connection with the sale of Atmel products, expressly or by implication. Atmel's products are not authorized for use as critical components in life support devices or systems.

© Atmel Corporation 2004. All rights reserved. Atmel® and combinations thereof are the registered trademarks of Atmel Corporation or its subsidiaries. Other terms and product names may be the trademarks of others.



Printed on recycled paper.

4330B-CAN-03/04 /xM