

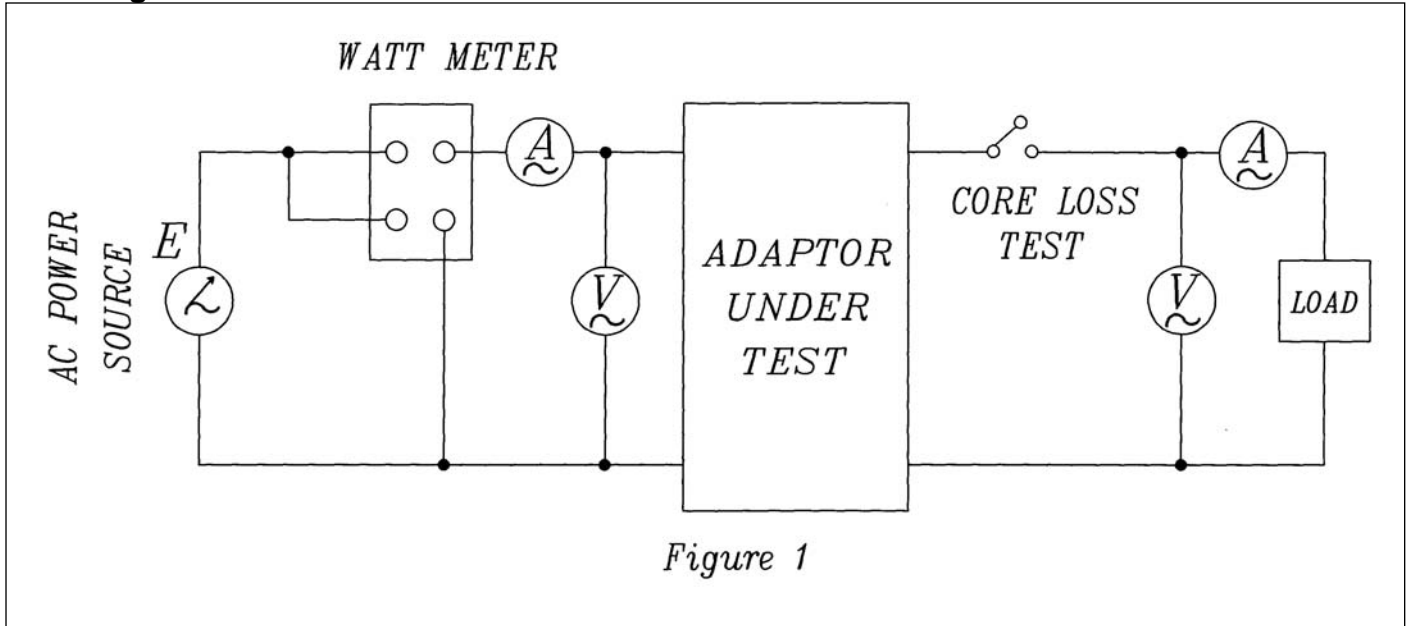

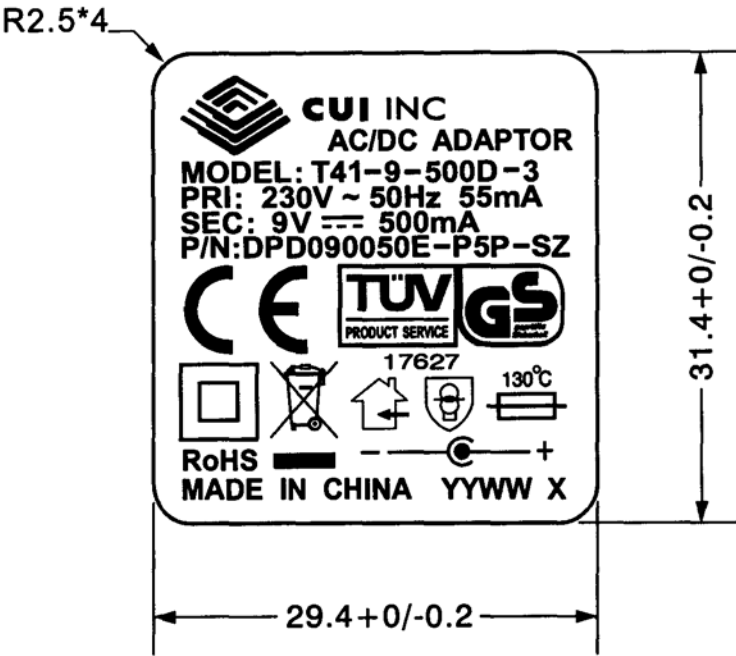



**Specifications**





Output voltage	9 V dc at 500 mA	
Primary rated input	230 V ac 50 Hz 55 mA	
Primary exciting current	50 mA rms max.	
Secondary rated voltage & current	no load voltage (max.)	14 V max.
	full load volatge (200 mA)	9 V $\pm$ 5%
Temperature rise of primary winding (full load)	70°C max. using resistance method	
Insulation resistance	$\geq$ 100 M Ohm at 500 V dc	
HI-POT test	from input to output for 1 min.	3000 V ac at 2 mA
	from input to output for 1 sec.	3750 V ac at 2 mA
	from primary to seconardy winding for 1 sec.	4500 V ac at 2 mA
	from primary winding to core for 1 sec.	4500 V ac at 2 mA
	from secondary winding to core for 1 sec.	1500 V ac at 2 mA
Safety standard	TUV/GS, CE	
RoHS compliant	yes	
Test conditions	Ambient temp	40°C $\pm$ 2°C
	Humidity	90-95% 96 hours at Full Load
	Rated voltage	8 hours at full load
Color	Case	black
	Cord	black
	Plug top	black





**Test Diagram**

**Label**



**CUI INC**  
**AC/DC ADAPTOR**  
**MODEL: T41-9-500D-3**  
**PRI: 230V ~ 50Hz 55mA**  
**SEC: 9V --- 500mA**  
**P/N:DPD090050E-P5P-SZ**



  
PRODUCT SERVICE  
17627

**RoHS**      
**MADE IN CHINA YYWW X**

Adhesive tape: 3m #44 tape 18 width  
 Thickness: 0.2mm  
 Material: PVC polyester  
 Color: black on silver base

Remarks: YYWW S  
 YY=production year  
 WW=production week  
 S=production location

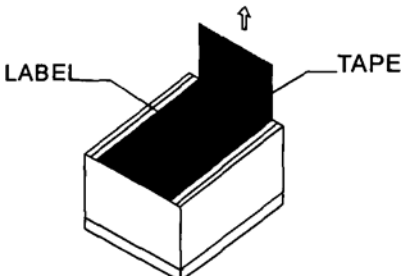



### Mechanical Drawing

Tolerance:  $\pm 1$

Weight

335 g

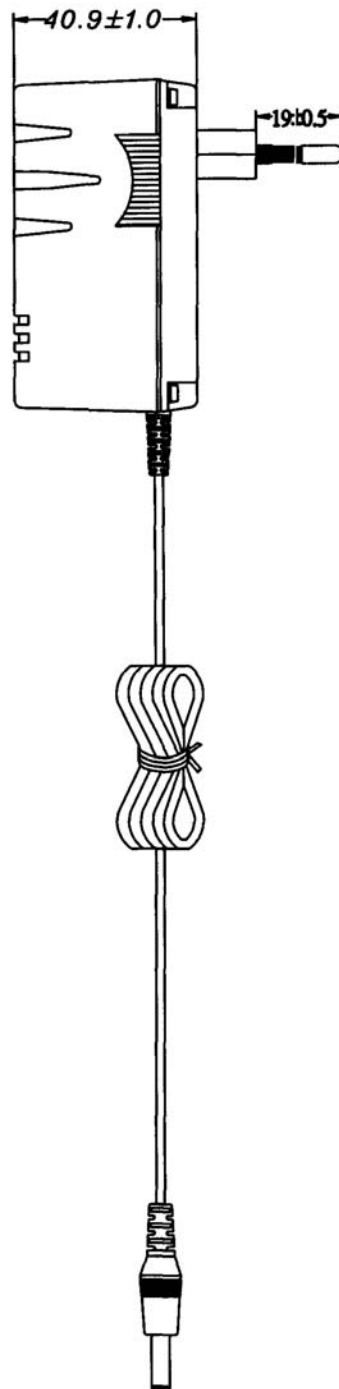
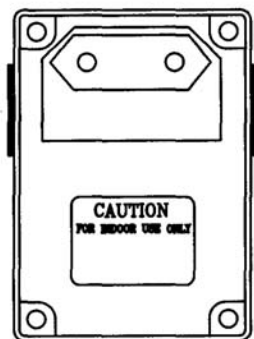
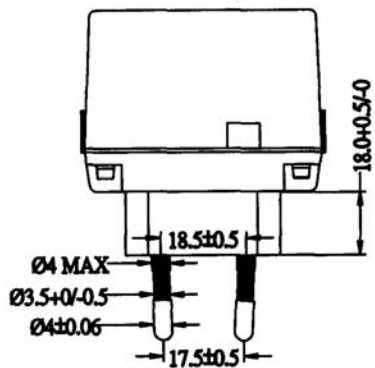
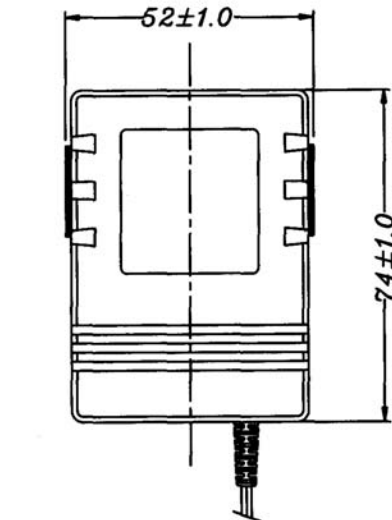



**Cord**

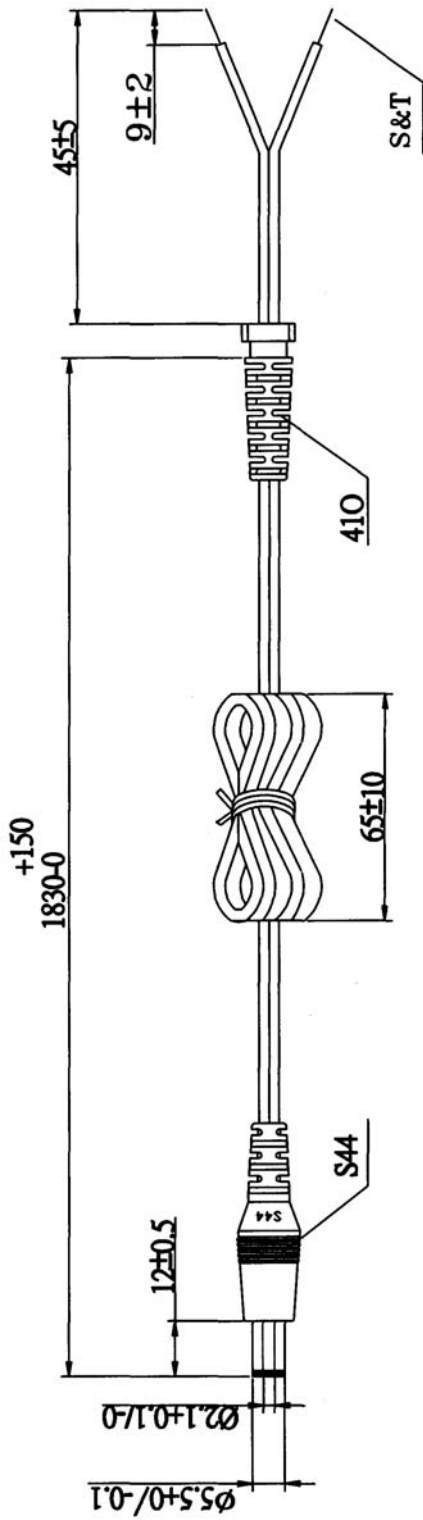

BLACK WIRE IN OUTER, BLACK/WHITE WIRE IN INNER

#24AWG X2C BLACK/WHITE



WIRE OD: Ø1.8X3.6

Parameter request	a. 360° b. WEIGHT 200g c. 40 ROUND/MINUTE d. OVER 1000 COUNT MIN
VIBRATION TEST	



**Circuit Diagrams**

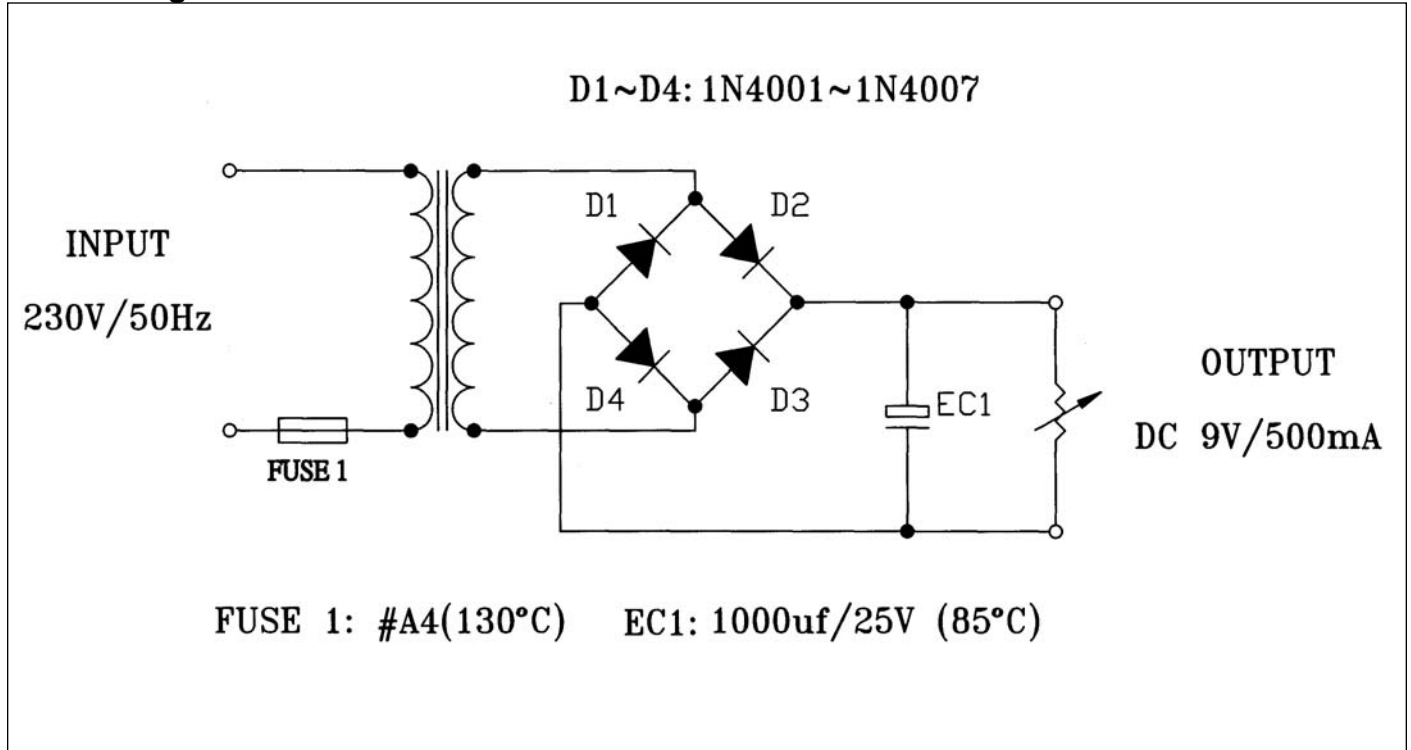



**CUI INC**

Part No: DPD090050E-P5P-SZ

Date: 2/27/2006

Unit: mm

Description: linear power supply

Page No: 6 of 7

### Packaging

Tolerance:  $\pm 1$

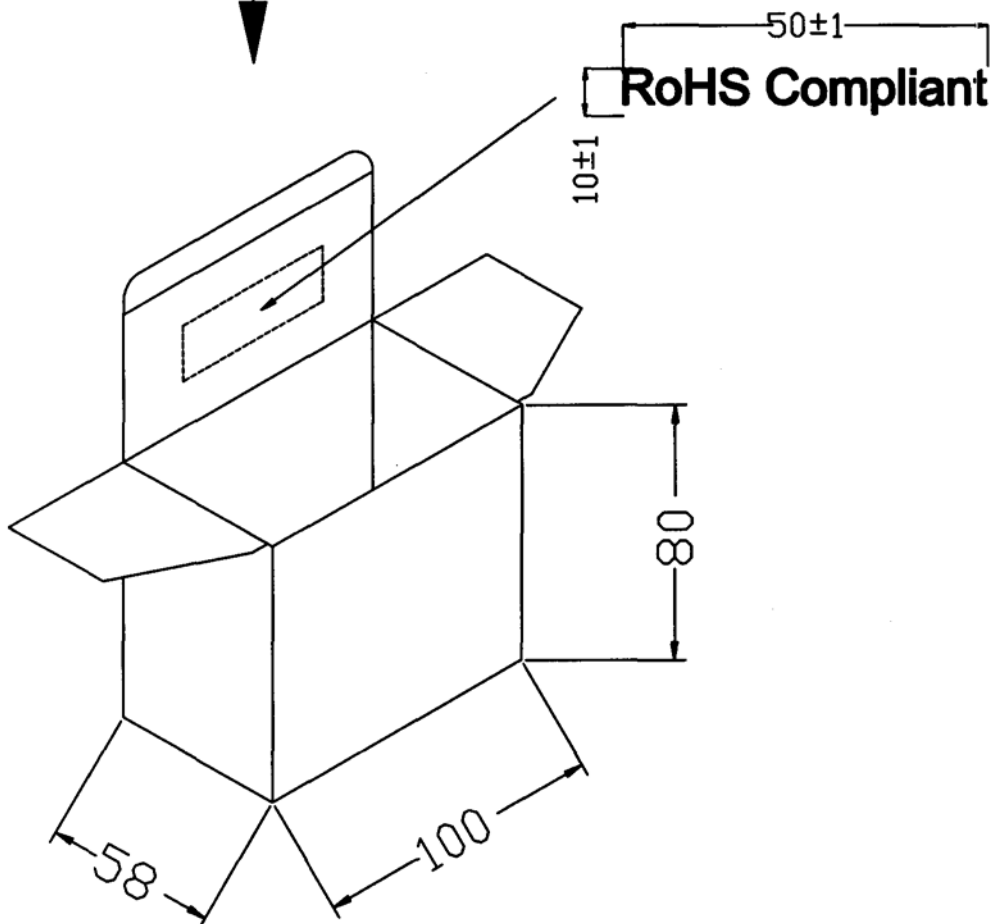
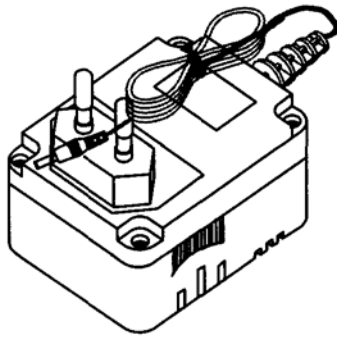



**Packaging**

Tolerance: +7/-0

OUTSIDE CARTON:A=B(6mm)  
INSIDE CARTON:A-B(3mm)  
CARTON SIZE: 430x223x269mm

Q'TY: 40pcs(10X4X1)

