

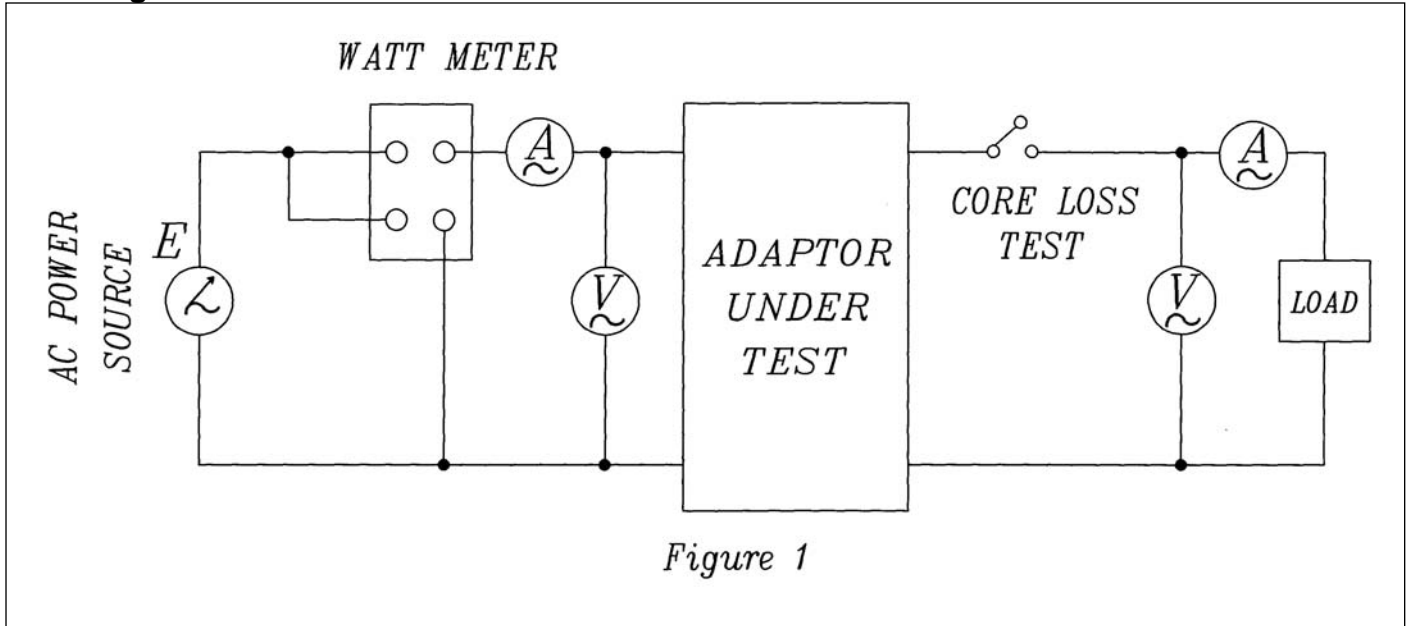

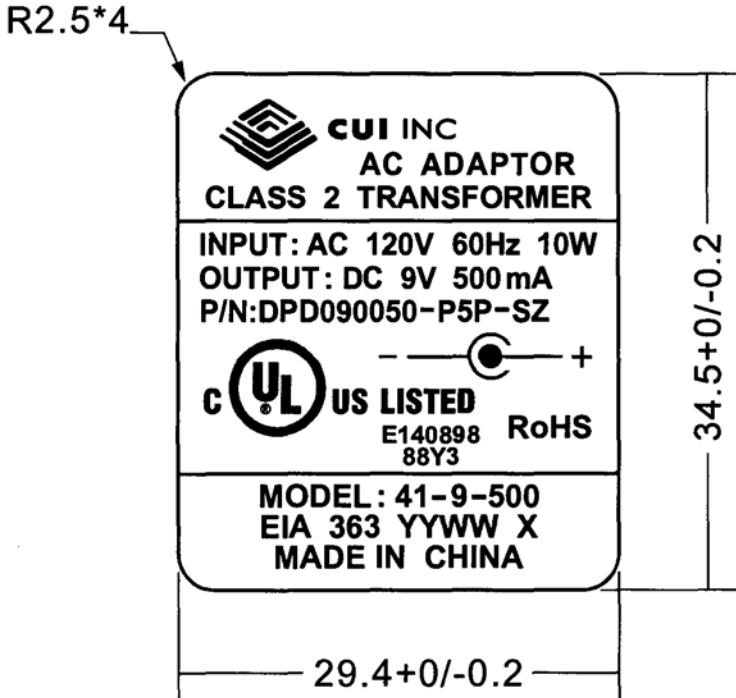

**Specifications**

Output voltage	9 V dc at 500 mA	
Primary rated input	120 V ac 60 Hz 10 W	
Primary exciting current	70 mA rms max.	
Secondary rated voltage & current	no load voltage (max.)	14 V max.
	full load volatge (500 mA)	9 V $\pm$ 5%
Temperature rise of primary winding (full load)	70°C max. using resistance method	
Insulation resistance	$\geq$ 100 M Ohm at 500 V dc	
HI-POT test	from input to output for 1 min.	1240 V ac at 2 mA
	from input to output for 1 sec.	1600 V ac at 2 mA
	from primary to seconardy winding for 1 sec.	1600 V ac at 2 mA
	from primary winding to core for 1 sec.	1600 V ac at 2 mA
	from secondary winding to core for 1 sec.	750 V ac at 2 mA
Safety standard	UL/cUL	
RoHS compliant	yes	
Test conditions	Ambient temp	40°C $\pm$ 2°C
	Humidity	90-95% 96 hours at Full Load
	Rated voltage	8 hours at full load
Color	Case	black
	Cord	black
	Plug top	black

**Test Diagram**

**Label**



**CUI INC**  
**AC ADAPTOR**  
**CLASS 2 TRANSFORMER**  
 INPUT: AC 120V 60Hz 10W  
 OUTPUT: DC 9V 500mA  
 P/N:DPD090050-P5P-SZ  
 **US LISTED**  
 E140898 RoHS  
 88Y3  
 MODEL: 41-9-500  
 EIA 363 YYWW X  
 MADE IN CHINA

Adhesive tape: 3m #44 tape 18 width  
 Thickness: 0.2mm  
 Material: PVC polyester  
 Color: black on silver base

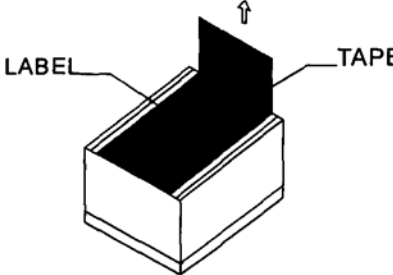
Remarks: YYWW S  
 YY=production year  
 WW=production week  
 S=production location





**CUI INC**

Part No: DPD090050-P5P-SZ

Date: 2/27/2006

Unit: mm

Description: linear power supply

Page No: 3 of 7

### Mechanical Drawing

Tolerance:  $\pm 1$

Weight

256 g

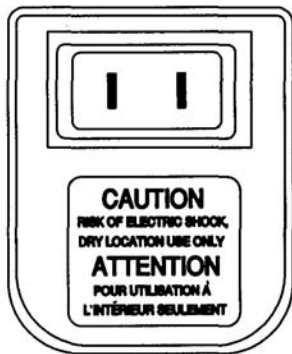
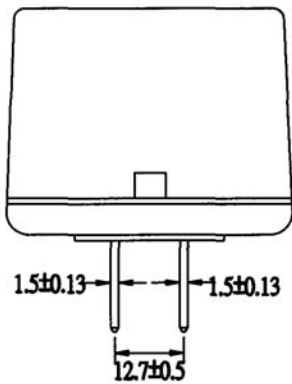
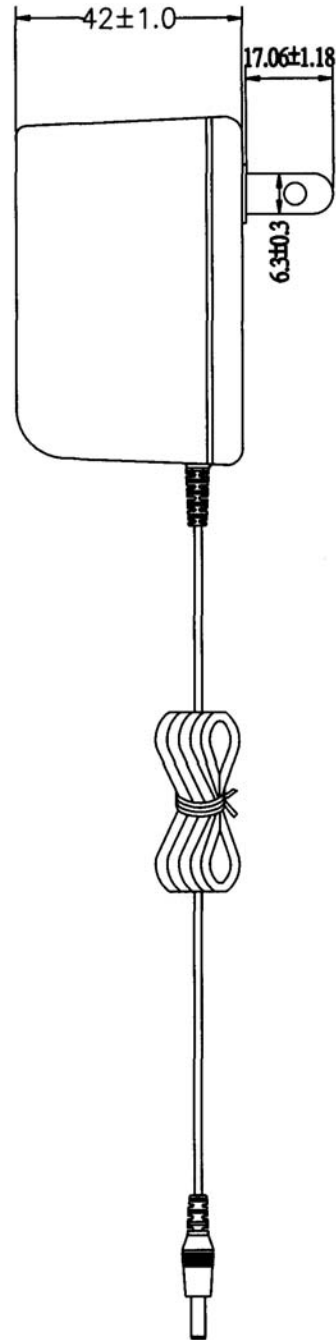
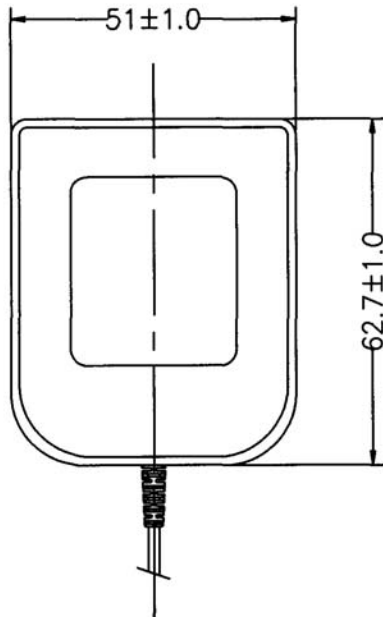



Cord

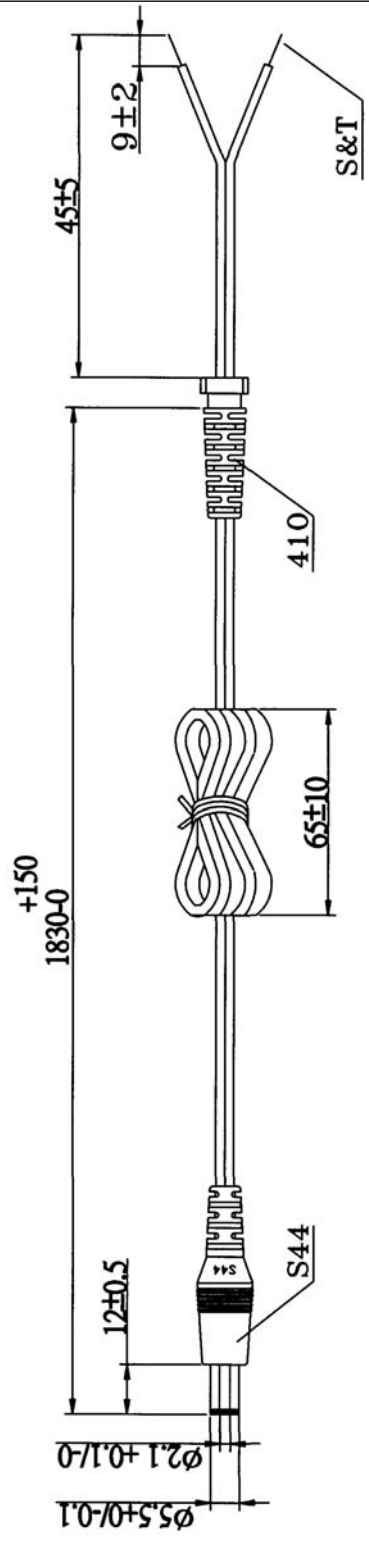

#24AWG X2C BLACK/WHITE WIRE BLACK WIRE IN OUTER, BLACK/WHITE WIRE IN INNER

WIRE OD: Ø1.8X3.6



Parameter request	
VIBRATION TEST	a. ±60'
	b. WEIGHT 200g
	c. 40 ROUND/MINUTE
	d. OVER 1000 COUNT MIN



**Circuit Diagrams**

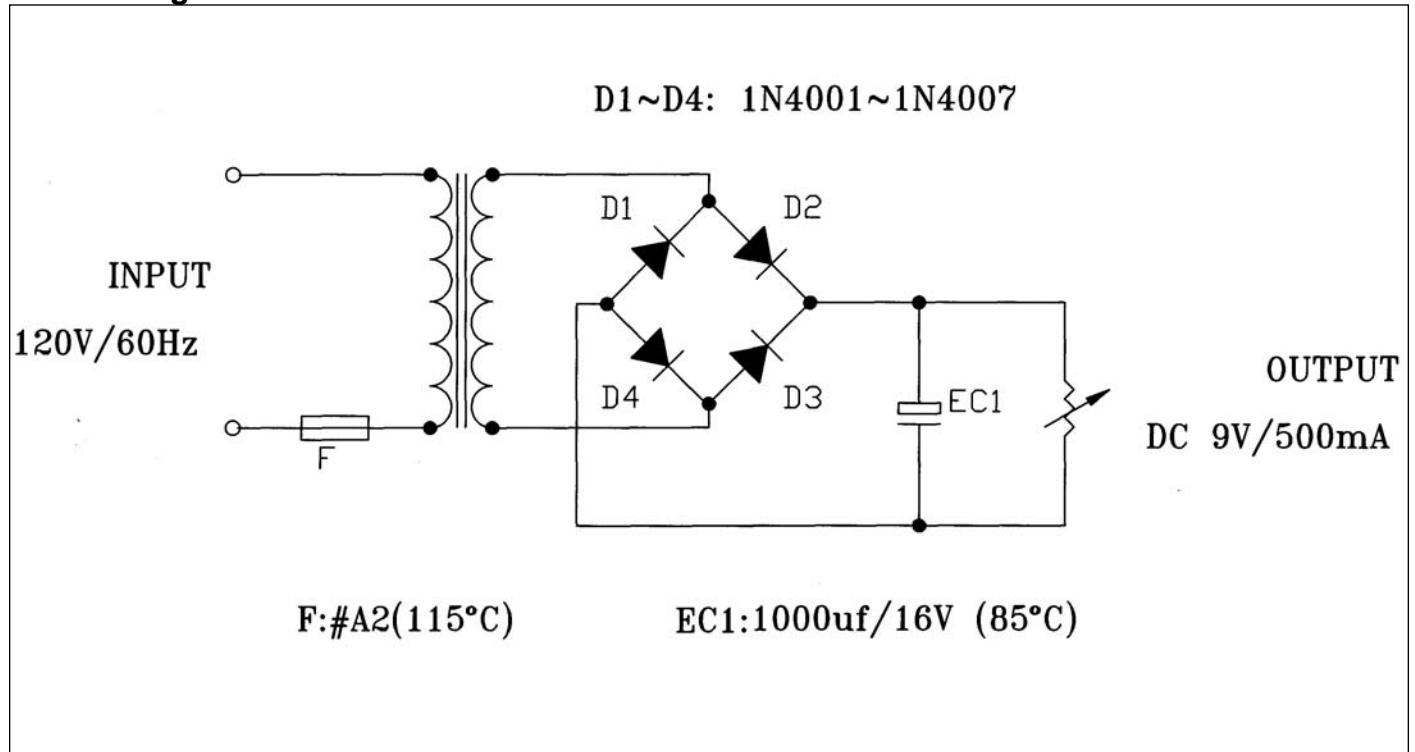



**CUI INC**

Part No: DPD090050-P5P-SZ

Date: 2/27/2006

Unit: mm

Description: linear power supply

Page No: 6 of 7

### Packaging

Tolerance:  $\pm 1$

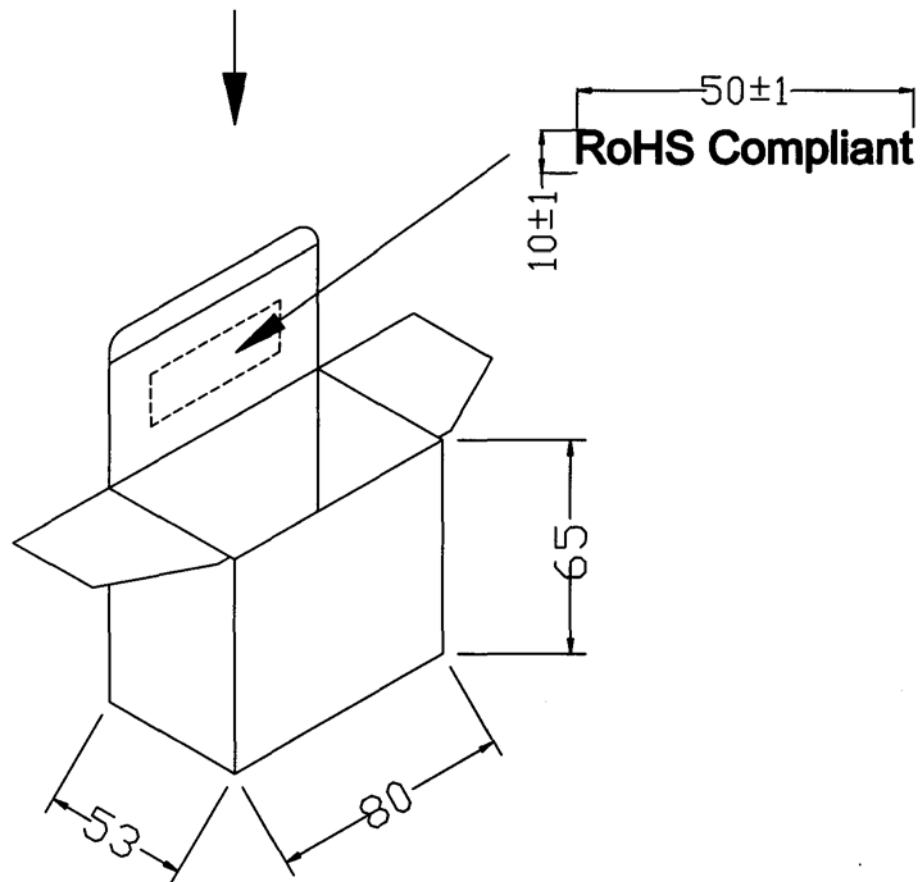
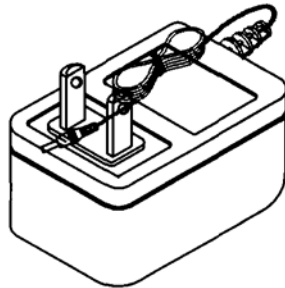



**Packaging**

Tolerance: +7/-0

OUTSIDE CARTON:A=B(6mm)

INSIDE CARTON:A-B(3mm)

CARTON SIZE: 350X345X190mm

Q'TY: 60pcs(20x3x1)

